



# Harper

## Assessment Property Record Card for Tax Year 2026

Data provided by SHAYLYN WEDER County Assessor

Date 02/06/2026  
 Time 06:26:10  
 Page 1

| Assessment Data   |                       |                        |              |             | Primary Image  |   |            |         |           |          |                  |              |            |             |                     |                       |              |        |                |                        |                |            |        |       |                |                      |                |                       |                    |               |               |              |  |      |                |                       |        |        |                 |              |                |          |                  |                       |                      |              |   |       |        |      |                |                       |     |        |   |       |        |      |                |                       |     |        |   |       |        |      |              |                       |     |        |  |       |        |      |              |                       |     |        |  |       |        |      |              |                       |     |        |  |       |        |      |              |                       |     |        |  |       |        |      |              |                       |     |        |  |       |        |      |              |                       |     |        |  |       |        |      |              |                       |     |        |  |       |        |
|---|-----------------------|------------------------|--------------|-------------|--|---|------------|---------|-----------|----------|------------------|--------------|------------|-------------|---------------------|-----------------------|--------------|--------|----------------|------------------------|----------------|------------|--------|-------|----------------|----------------------|----------------|-----------------------|--------------------|---------------|---------------|--------------|--|------|----------------|-----------------------|--------|--------|-----------------|--------------|----------------|----------|------------------|-----------------------|----------------------|--------------|---|-------|--------|------|----------------|-----------------------|-----|--------|---|-------|--------|------|----------------|-----------------------|-----|--------|---|-------|--------|------|--------------|-----------------------|-----|--------|--|-------|--------|------|--------------|-----------------------|-----|--------|--|-------|--------|------|--------------|-----------------------|-----|--------|--|-------|--------|------|--------------|-----------------------|-----|--------|--|-------|--------|------|--------------|-----------------------|-----|--------|--|-------|--------|------|--------------|-----------------------|-----|--------|--|-------|--------|------|--------------|-----------------------|-----|--------|--|-------|--------|
| <b>Account</b> 300002502<br><b>Parcel ID</b> 0000-12-27N-23W-3-003-00<br><b>Cadastral ID</b> 0000-27N-23W-12-3-003-00<br><b>Property Type</b> REAL - Real Property<br><b>Property Class</b> RR VI Area 4<br><b>Tax Area</b> 102 - 4R-BUFFALO<br><b>Name ID</b> 25799<br>THOMAS, JON DERICK AND<br>KRYSTAL BROOKE THOMAS<br><br>P O BOX 584<br>BUFFALO OK 73834-<br><br><b>Parcel Location</b><br><b>Situs</b> 00857 US 183 HWY<br><b>Subdivision</b><br><b>Lot/Block</b> / <b>Parcel Size</b> 3.68 - Acres<br><b>Sec/Twn/Rng</b> 12 / 27 / 23 / 3<br><b>Neighborhood</b> 100100 - BUFFALO ORIG/MILLERS<br><b>School District</b> 4-BUFFAL - 4-BUFFALO   |                       |                        |              |             |  |   |            |         |           |          |                  |              |            |             |                     |                       |              |        |                |                        |                |            |        |       |                |                      |                |                       |                    |               |               |              |  |      |                |                       |        |        |                 |              |                |          |                  |                       |                      |              |   |       |        |      |                |                       |     |        |   |       |        |      |                |                       |     |        |   |       |        |      |              |                       |     |        |  |       |        |      |              |                       |     |        |  |       |        |      |              |                       |     |        |  |       |        |      |              |                       |     |        |  |       |        |      |              |                       |     |        |  |       |        |      |              |                       |     |        |  |       |        |      |              |                       |     |        |  |       |        |
| <b>Legal Description</b> Lat/Long: 36.82985462 -99.63557077<br>SEC.12-27N-23W TRACT IN S/2SW4 CONT 3.68 LESS 0.09 TRACT(HWY)  |                       |                        |              |             |  |   |            |         |           |          |                  |              |            |             |                     |                       |              |        |                |                        |                |            |        |       |                |                      |                |                       |                    |               |               |              |  |      |                |                       |        |        |                 |              |                |          |                  |                       |                      |              |   |       |        |      |                |                       |     |        |   |       |        |      |                |                       |     |        |   |       |        |      |              |                       |     |        |  |       |        |      |              |                       |     |        |  |       |        |      |              |                       |     |        |  |       |        |      |              |                       |     |        |  |       |        |      |              |                       |     |        |  |       |        |      |              |                       |     |        |  |       |        |      |              |                       |     |        |  |       |        |
| <b>Exemptions</b>   |                       |                        |              |             | <b>Building Permits</b>  |   |            |         |           |          |                  |              |            |             |                     |                       |              |        |                |                        |                |            |        |       |                |                      |                |                       |                    |               |               |              |  |      |                |                       |        |        |                 |              |                |          |                  |                       |                      |              |   |       |        |      |                |                       |     |        |   |       |        |      |                |                       |     |        |   |       |        |      |              |                       |     |        |  |       |        |      |              |                       |     |        |  |       |        |      |              |                       |     |        |  |       |        |      |              |                       |     |        |  |       |        |      |              |                       |     |        |  |       |        |      |              |                       |     |        |  |       |        |      |              |                       |     |        |  |       |        |
|   |                       |                        |              |             | <table border="1"> <thead> <tr> <th>Number</th> <th>Description</th> <th>Opened</th> <th>Closed</th> <th>Amount</th> </tr> </thead> <tbody> <tr> <td></td> <td></td> <td></td> <td></td> <td></td> </tr> </tbody> </table>   |   |            |         |           | Number   | Description      | Opened       | Closed     | Amount      |                     |                       |              |        |                |                        |                |            |        |       |                |                      |                |                       |                    |               |               |              |  |      |                |                       |        |        |                 |              |                |          |                  |                       |                      |              |   |       |        |      |                |                       |     |        |   |       |        |      |                |                       |     |        |   |       |        |      |              |                       |     |        |  |       |        |      |              |                       |     |        |  |       |        |      |              |                       |     |        |  |       |        |      |              |                       |     |        |  |       |        |      |              |                       |     |        |  |       |        |      |              |                       |     |        |  |       |        |      |              |                       |     |        |  |       |        |
| Number  | Description           | Opened                 | Closed       | Amount      |  |   |            |         |           |          |                  |              |            |             |                     |                       |              |        |                |                        |                |            |        |       |                |                      |                |                       |                    |               |               |              |  |      |                |                       |        |        |                 |              |                |          |                  |                       |                      |              |   |       |        |      |                |                       |     |        |   |       |        |      |                |                       |     |        |   |       |        |      |              |                       |     |        |  |       |        |      |              |                       |     |        |  |       |        |      |              |                       |     |        |  |       |        |      |              |                       |     |        |  |       |        |      |              |                       |     |        |  |       |        |      |              |                       |     |        |  |       |        |      |              |                       |     |        |  |       |        |
|   |                       |                        |              |             |  |   |            |         |           |          |                  |              |            |             |                     |                       |              |        |                |                        |                |            |        |       |                |                      |                |                       |                    |               |               |              |  |      |                |                       |        |        |                 |              |                |          |                  |                       |                      |              |   |       |        |      |                |                       |     |        |   |       |        |      |                |                       |     |        |   |       |        |      |              |                       |     |        |  |       |        |      |              |                       |     |        |  |       |        |      |              |                       |     |        |  |       |        |      |              |                       |     |        |  |       |        |      |              |                       |     |        |  |       |        |      |              |                       |     |        |  |       |        |      |              |                       |     |        |  |       |        |
| <table border="1"> <thead> <tr> <th>Code</th> <th>Type</th> <th>Active</th> <th>Maximum</th> <th>Exemption</th> </tr> </thead> <tbody> <tr> <td></td> <td></td> <td></td> <td></td> <td></td> </tr> </tbody> </table>   |                       |                        |              |             | Code   | Type  | Active     | Maximum | Exemption |          |                  |              |            |             | <b>Sale History</b> |                       |              |        |                |                        |                |            |        |       |                |                      |                |                       |                    |               |               |              |  |      |                |                       |        |        |                 |              |                |          |                  |                       |                      |              |   |       |        |      |                |                       |     |        |   |       |        |      |                |                       |     |        |   |       |        |      |              |                       |     |        |  |       |        |      |              |                       |     |        |  |       |        |      |              |                       |     |        |  |       |        |      |              |                       |     |        |  |       |        |      |              |                       |     |        |  |       |        |      |              |                       |     |        |  |       |        |      |              |                       |     |        |  |       |        |
| Code  | Type                  | Active                 | Maximum      | Exemption   |  |   |            |         |           |          |                  |              |            |             |                     |                       |              |        |                |                        |                |            |        |       |                |                      |                |                       |                    |               |               |              |  |      |                |                       |        |        |                 |              |                |          |                  |                       |                      |              |   |       |        |      |                |                       |     |        |   |       |        |      |                |                       |     |        |   |       |        |      |              |                       |     |        |  |       |        |      |              |                       |     |        |  |       |        |      |              |                       |     |        |  |       |        |      |              |                       |     |        |  |       |        |      |              |                       |     |        |  |       |        |      |              |                       |     |        |  |       |        |      |              |                       |     |        |  |       |        |
|   |                       |                        |              |             |  |   |            |         |           |          |                  |              |            |             |                     |                       |              |        |                |                        |                |            |        |       |                |                      |                |                       |                    |               |               |              |  |      |                |                       |        |        |                 |              |                |          |                  |                       |                      |              |   |       |        |      |                |                       |     |        |   |       |        |      |                |                       |     |        |   |       |        |      |              |                       |     |        |  |       |        |      |              |                       |     |        |  |       |        |      |              |                       |     |        |  |       |        |      |              |                       |     |        |  |       |        |      |              |                       |     |        |  |       |        |      |              |                       |     |        |  |       |        |      |              |                       |     |        |  |       |        |
|   |                       |                        |              |             | <table border="1"> <thead> <tr> <th>Bk/Pg</th> <th>Grantor</th> <th>Date</th> <th>Price</th> <th>Code</th> </tr> </thead> <tbody> <tr> <td>791/161</td> <td>ROBERTSON, MICHAEL G.</td> <td>08/05/2025</td> <td>40,000</td> <td>17</td> </tr> <tr> <td>685/771</td> <td>YAUK, RAY</td> <td>12/18/2012</td> <td>38,000</td> <td>Q</td> </tr> <tr> <td>665/170</td> <td>LEDFOORD, THERESE B.</td> <td>10/11/2010</td> <td>39,000</td> <td>MQ</td> </tr> </tbody> </table> |   |            |         |           | Bk/Pg    | Grantor          | Date         | Price      | Code        | 791/161             | ROBERTSON, MICHAEL G. | 08/05/2025   | 40,000 | 17             | 685/771                | YAUK, RAY      | 12/18/2012 | 38,000 | Q     | 665/170        | LEDFOORD, THERESE B. | 10/11/2010     | 39,000                | MQ                 |               |               |              |  |      |                |                       |        |        |                 |              |                |          |                  |                       |                      |              |   |       |        |      |                |                       |     |        |   |       |        |      |                |                       |     |        |   |       |        |      |              |                       |     |        |  |       |        |      |              |                       |     |        |  |       |        |      |              |                       |     |        |  |       |        |      |              |                       |     |        |  |       |        |      |              |                       |     |        |  |       |        |      |              |                       |     |        |  |       |        |      |              |                       |     |        |  |       |        |
| Bk/Pg   | Grantor               | Date                   | Price        | Code        |  |   |            |         |           |          |                  |              |            |             |                     |                       |              |        |                |                        |                |            |        |       |                |                      |                |                       |                    |               |               |              |  |      |                |                       |        |        |                 |              |                |          |                  |                       |                      |              |   |       |        |      |                |                       |     |        |   |       |        |      |                |                       |     |        |   |       |        |      |              |                       |     |        |  |       |        |      |              |                       |     |        |  |       |        |      |              |                       |     |        |  |       |        |      |              |                       |     |        |  |       |        |      |              |                       |     |        |  |       |        |      |              |                       |     |        |  |       |        |      |              |                       |     |        |  |       |        |
| 791/161   | ROBERTSON, MICHAEL G. | 08/05/2025             | 40,000       | 17          |  |   |            |         |           |          |                  |              |            |             |                     |                       |              |        |                |                        |                |            |        |       |                |                      |                |                       |                    |               |               |              |  |      |                |                       |        |        |                 |              |                |          |                  |                       |                      |              |   |       |        |      |                |                       |     |        |   |       |        |      |                |                       |     |        |   |       |        |      |              |                       |     |        |  |       |        |      |              |                       |     |        |  |       |        |      |              |                       |     |        |  |       |        |      |              |                       |     |        |  |       |        |      |              |                       |     |        |  |       |        |      |              |                       |     |        |  |       |        |      |              |                       |     |        |  |       |        |
| 685/771   | YAUK, RAY             | 12/18/2012             | 38,000       | Q           |  |   |            |         |           |          |                  |              |            |             |                     |                       |              |        |                |                        |                |            |        |       |                |                      |                |                       |                    |               |               |              |  |      |                |                       |        |        |                 |              |                |          |                  |                       |                      |              |   |       |        |      |                |                       |     |        |   |       |        |      |                |                       |     |        |   |       |        |      |              |                       |     |        |  |       |        |      |              |                       |     |        |  |       |        |      |              |                       |     |        |  |       |        |      |              |                       |     |        |  |       |        |      |              |                       |     |        |  |       |        |      |              |                       |     |        |  |       |        |      |              |                       |     |        |  |       |        |
| 665/170   | LEDFOORD, THERESE B.  | 10/11/2010             | 39,000       | MQ          |  |   |            |         |           |          |                  |              |            |             |                     |                       |              |        |                |                        |                |            |        |       |                |                      |                |                       |                    |               |               |              |  |      |                |                       |        |        |                 |              |                |          |                  |                       |                      |              |   |       |        |      |                |                       |     |        |   |       |        |      |                |                       |     |        |   |       |        |      |              |                       |     |        |  |       |        |      |              |                       |     |        |  |       |        |      |              |                       |     |        |  |       |        |      |              |                       |     |        |  |       |        |      |              |                       |     |        |  |       |        |      |              |                       |     |        |  |       |        |      |              |                       |     |        |  |       |        |
| <b>Parcel Valuation</b>   |                       |                        |              |             |  |   |            |         |           |          |                  |              |            |             |                     |                       |              |        |                |                        |                |            |        |       |                |                      |                |                       |                    |               |               |              |  |      |                |                       |        |        |                 |              |                |          |                  |                       |                      |              |   |       |        |      |                |                       |     |        |   |       |        |      |                |                       |     |        |   |       |        |      |              |                       |     |        |  |       |        |      |              |                       |     |        |  |       |        |      |              |                       |     |        |  |       |        |      |              |                       |     |        |  |       |        |      |              |                       |     |        |  |       |        |      |              |                       |     |        |  |       |        |      |              |                       |     |        |  |       |        |
| <table border="1"> <thead> <tr> <th>Source</th> <th>REAL</th> </tr> </thead> <tbody> <tr> <td>Remove Cap</td> <td>2026</td> </tr> </tbody> </table>   |                       | Source                 | REAL         | Remove Cap  | 2026   | <table border="1"> <thead> <tr> <th>Fair Cash</th> <th>Capped</th> <th>Asmnt Level</th> <th>Assessed</th> </tr> </thead> <tbody> <tr> <td>Land Value</td> <td>7,010</td> <td>7,010</td> <td>841</td> </tr> <tr> <td>Improvements</td> <td>20,327</td> <td>20,327</td> <td>2,439</td> </tr> <tr> <td>Uncapped Value</td> <td>0</td> <td>0</td> <td>0</td> </tr> <tr> <td>TIF Project ID</td> <td>0</td> <td>0</td> <td>0</td> </tr> <tr> <td><b>Total Value</b></td> <td><b>27,337</b></td> <td><b>27,337</b></td> <td><b>3,280</b></td> </tr> </tbody> </table> |            |         | Fair Cash | Capped   | Asmnt Level      | Assessed     | Land Value | 7,010       | 7,010               | 841                   | Improvements | 20,327 | 20,327         | 2,439                  | Uncapped Value | 0          | 0      | 0     | TIF Project ID | 0                    | 0              | 0                     | <b>Total Value</b> | <b>27,337</b> | <b>27,337</b> | <b>3,280</b> | <table border="1"> <thead> <tr> <th>Levy Rate</th> <th>Current Tax</th> </tr> </thead> <tbody> <tr> <td>78.740</td> <td>258.27</td> </tr> <tr> <td><b>Assessed</b></td> <td><b>3,280</b></td> </tr> <tr> <td><b>Penalty</b></td> <td><b>0</b></td> </tr> <tr> <td><b>Exemption</b></td> <td><b>0</b></td> </tr> <tr> <td><b>Total Taxable</b></td> <td><b>3,280</b></td> </tr> </tbody> </table> |      | Levy Rate      | Current Tax           | 78.740 | 258.27 | <b>Assessed</b> | <b>3,280</b> | <b>Penalty</b> | <b>0</b> | <b>Exemption</b> | <b>0</b>              | <b>Total Taxable</b> | <b>3,280</b> |   |       |        |      |                |                       |     |        |   |       |        |      |                |                       |     |        |   |       |        |      |              |                       |     |        |  |       |        |      |              |                       |     |        |  |       |        |      |              |                       |     |        |  |       |        |      |              |                       |     |        |  |       |        |      |              |                       |     |        |  |       |        |      |              |                       |     |        |  |       |        |      |              |                       |     |        |  |       |        |
| Source  | REAL                  |                        |              |             |  |   |            |         |           |          |                  |              |            |             |                     |                       |              |        |                |                        |                |            |        |       |                |                      |                |                       |                    |               |               |              |  |      |                |                       |        |        |                 |              |                |          |                  |                       |                      |              |   |       |        |      |                |                       |     |        |   |       |        |      |                |                       |     |        |   |       |        |      |              |                       |     |        |  |       |        |      |              |                       |     |        |  |       |        |      |              |                       |     |        |  |       |        |      |              |                       |     |        |  |       |        |      |              |                       |     |        |  |       |        |      |              |                       |     |        |  |       |        |      |              |                       |     |        |  |       |        |
| Remove Cap  | 2026                  |                        |              |             |  |   |            |         |           |          |                  |              |            |             |                     |                       |              |        |                |                        |                |            |        |       |                |                      |                |                       |                    |               |               |              |  |      |                |                       |        |        |                 |              |                |          |                  |                       |                      |              |   |       |        |      |                |                       |     |        |   |       |        |      |                |                       |     |        |   |       |        |      |              |                       |     |        |  |       |        |      |              |                       |     |        |  |       |        |      |              |                       |     |        |  |       |        |      |              |                       |     |        |  |       |        |      |              |                       |     |        |  |       |        |      |              |                       |     |        |  |       |        |      |              |                       |     |        |  |       |        |
| Fair Cash   | Capped                | Asmnt Level            | Assessed     |             |  |   |            |         |           |          |                  |              |            |             |                     |                       |              |        |                |                        |                |            |        |       |                |                      |                |                       |                    |               |               |              |  |      |                |                       |        |        |                 |              |                |          |                  |                       |                      |              |   |       |        |      |                |                       |     |        |   |       |        |      |                |                       |     |        |   |       |        |      |              |                       |     |        |  |       |        |      |              |                       |     |        |  |       |        |      |              |                       |     |        |  |       |        |      |              |                       |     |        |  |       |        |      |              |                       |     |        |  |       |        |      |              |                       |     |        |  |       |        |      |              |                       |     |        |  |       |        |
| Land Value  | 7,010                 | 7,010                  | 841          |             |  |   |            |         |           |          |                  |              |            |             |                     |                       |              |        |                |                        |                |            |        |       |                |                      |                |                       |                    |               |               |              |  |      |                |                       |        |        |                 |              |                |          |                  |                       |                      |              |   |       |        |      |                |                       |     |        |   |       |        |      |                |                       |     |        |   |       |        |      |              |                       |     |        |  |       |        |      |              |                       |     |        |  |       |        |      |              |                       |     |        |  |       |        |      |              |                       |     |        |  |       |        |      |              |                       |     |        |  |       |        |      |              |                       |     |        |  |       |        |      |              |                       |     |        |  |       |        |
| Improvements  | 20,327                | 20,327                 | 2,439        |             |  |   |            |         |           |          |                  |              |            |             |                     |                       |              |        |                |                        |                |            |        |       |                |                      |                |                       |                    |               |               |              |  |      |                |                       |        |        |                 |              |                |          |                  |                       |                      |              |   |       |        |      |                |                       |     |        |   |       |        |      |                |                       |     |        |   |       |        |      |              |                       |     |        |  |       |        |      |              |                       |     |        |  |       |        |      |              |                       |     |        |  |       |        |      |              |                       |     |        |  |       |        |      |              |                       |     |        |  |       |        |      |              |                       |     |        |  |       |        |      |              |                       |     |        |  |       |        |
| Uncapped Value  | 0                     | 0                      | 0            |             |  |   |            |         |           |          |                  |              |            |             |                     |                       |              |        |                |                        |                |            |        |       |                |                      |                |                       |                    |               |               |              |  |      |                |                       |        |        |                 |              |                |          |                  |                       |                      |              |   |       |        |      |                |                       |     |        |   |       |        |      |                |                       |     |        |   |       |        |      |              |                       |     |        |  |       |        |      |              |                       |     |        |  |       |        |      |              |                       |     |        |  |       |        |      |              |                       |     |        |  |       |        |      |              |                       |     |        |  |       |        |      |              |                       |     |        |  |       |        |      |              |                       |     |        |  |       |        |
| TIF Project ID  | 0                     | 0                      | 0            |             |  |   |            |         |           |          |                  |              |            |             |                     |                       |              |        |                |                        |                |            |        |       |                |                      |                |                       |                    |               |               |              |  |      |                |                       |        |        |                 |              |                |          |                  |                       |                      |              |   |       |        |      |                |                       |     |        |   |       |        |      |                |                       |     |        |   |       |        |      |              |                       |     |        |  |       |        |      |              |                       |     |        |  |       |        |      |              |                       |     |        |  |       |        |      |              |                       |     |        |  |       |        |      |              |                       |     |        |  |       |        |      |              |                       |     |        |  |       |        |      |              |                       |     |        |  |       |        |
| <b>Total Value</b>  | <b>27,337</b>         | <b>27,337</b>          | <b>3,280</b> |             |  |   |            |         |           |          |                  |              |            |             |                     |                       |              |        |                |                        |                |            |        |       |                |                      |                |                       |                    |               |               |              |  |      |                |                       |        |        |                 |              |                |          |                  |                       |                      |              |   |       |        |      |                |                       |     |        |   |       |        |      |                |                       |     |        |   |       |        |      |              |                       |     |        |  |       |        |      |              |                       |     |        |  |       |        |      |              |                       |     |        |  |       |        |      |              |                       |     |        |  |       |        |      |              |                       |     |        |  |       |        |      |              |                       |     |        |  |       |        |      |              |                       |     |        |  |       |        |
| Levy Rate   | Current Tax           |                        |              |             |  |   |            |         |           |          |                  |              |            |             |                     |                       |              |        |                |                        |                |            |        |       |                |                      |                |                       |                    |               |               |              |  |      |                |                       |        |        |                 |              |                |          |                  |                       |                      |              |   |       |        |      |                |                       |     |        |   |       |        |      |                |                       |     |        |   |       |        |      |              |                       |     |        |  |       |        |      |              |                       |     |        |  |       |        |      |              |                       |     |        |  |       |        |      |              |                       |     |        |  |       |        |      |              |                       |     |        |  |       |        |      |              |                       |     |        |  |       |        |      |              |                       |     |        |  |       |        |
| 78.740  | 258.27                |                        |              |             |  |   |            |         |           |          |                  |              |            |             |                     |                       |              |        |                |                        |                |            |        |       |                |                      |                |                       |                    |               |               |              |  |      |                |                       |        |        |                 |              |                |          |                  |                       |                      |              |   |       |        |      |                |                       |     |        |   |       |        |      |                |                       |     |        |   |       |        |      |              |                       |     |        |  |       |        |      |              |                       |     |        |  |       |        |      |              |                       |     |        |  |       |        |      |              |                       |     |        |  |       |        |      |              |                       |     |        |  |       |        |      |              |                       |     |        |  |       |        |      |              |                       |     |        |  |       |        |
| <b>Assessed</b>   | <b>3,280</b>          |                        |              |             |  |   |            |         |           |          |                  |              |            |             |                     |                       |              |        |                |                        |                |            |        |       |                |                      |                |                       |                    |               |               |              |  |      |                |                       |        |        |                 |              |                |          |                  |                       |                      |              |   |       |        |      |                |                       |     |        |   |       |        |      |                |                       |     |        |   |       |        |      |              |                       |     |        |  |       |        |      |              |                       |     |        |  |       |        |      |              |                       |     |        |  |       |        |      |              |                       |     |        |  |       |        |      |              |                       |     |        |  |       |        |      |              |                       |     |        |  |       |        |      |              |                       |     |        |  |       |        |
| <b>Penalty</b>  | <b>0</b>              |                        |              |             |  |   |            |         |           |          |                  |              |            |             |                     |                       |              |        |                |                        |                |            |        |       |                |                      |                |                       |                    |               |               |              |  |      |                |                       |        |        |                 |              |                |          |                  |                       |                      |              |   |       |        |      |                |                       |     |        |   |       |        |      |                |                       |     |        |   |       |        |      |              |                       |     |        |  |       |        |      |              |                       |     |        |  |       |        |      |              |                       |     |        |  |       |        |      |              |                       |     |        |  |       |        |      |              |                       |     |        |  |       |        |      |              |                       |     |        |  |       |        |      |              |                       |     |        |  |       |        |
| <b>Exemption</b>  | <b>0</b>              |                        |              |             |  |   |            |         |           |          |                  |              |            |             |                     |                       |              |        |                |                        |                |            |        |       |                |                      |                |                       |                    |               |               |              |  |      |                |                       |        |        |                 |              |                |          |                  |                       |                      |              |   |       |        |      |                |                       |     |        |   |       |        |      |                |                       |     |        |   |       |        |      |              |                       |     |        |  |       |        |      |              |                       |     |        |  |       |        |      |              |                       |     |        |  |       |        |      |              |                       |     |        |  |       |        |      |              |                       |     |        |  |       |        |      |              |                       |     |        |  |       |        |      |              |                       |     |        |  |       |        |
| <b>Total Taxable</b>  | <b>3,280</b>          |                        |              |             |  |   |            |         |           |          |                  |              |            |             |                     |                       |              |        |                |                        |                |            |        |       |                |                      |                |                       |                    |               |               |              |  |      |                |                       |        |        |                 |              |                |          |                  |                       |                      |              |   |       |        |      |                |                       |     |        |   |       |        |      |                |                       |     |        |   |       |        |      |              |                       |     |        |  |       |        |      |              |                       |     |        |  |       |        |      |              |                       |     |        |  |       |        |      |              |                       |     |        |  |       |        |      |              |                       |     |        |  |       |        |      |              |                       |     |        |  |       |        |      |              |                       |     |        |  |       |        |
| <b>Assessment History</b>   |                       |                        |              |             |  |   |            |         |           |          |                  |              |            |             |                     |                       |              |        |                |                        |                |            |        |       |                |                      |                |                       |                    |               |               |              |  |      |                |                       |        |        |                 |              |                |          |                  |                       |                      |              |   |       |        |      |                |                       |     |        |   |       |        |      |                |                       |     |        |   |       |        |      |              |                       |     |        |  |       |        |      |              |                       |     |        |  |       |        |      |              |                       |     |        |  |       |        |      |              |                       |     |        |  |       |        |      |              |                       |     |        |  |       |        |      |              |                       |     |        |  |       |        |      |              |                       |     |        |  |       |        |
| <table border="1"> <thead> <tr> <th>Tax Year</th> <th>Statement Number</th> <th>Billed Owner</th> <th>Tax Area</th> <th>Total Value</th> <th>Exemptions</th> <th>Taxable Value</th> <th>Billed Tax</th> </tr> </thead> <tbody> <tr> <td>2025</td> <td>2025-300002502</td> <td>THOMAS, JON DERICK AND</td> <td>102</td> <td>27,337</td> <td>0</td> <td>2,936</td> <td>231.00</td> </tr> <tr> <td>2024</td> <td>2024-300002502</td> <td>ROBERTSON, MICHAEL G.</td> <td>102</td> <td>29,358</td> <td>0</td> <td>2,797</td> <td>228.00</td> </tr> <tr> <td>2023</td> <td>2023-300002502</td> <td>ROBERTSON, MICHAEL G.</td> <td>102</td> <td>27,010</td> <td>0</td> <td>2,664</td> <td>220.00</td> </tr> <tr> <td>2022</td> <td>2022-300002502</td> <td>ROBERTSON, MICHAEL G.</td> <td>102</td> <td>21,141</td> <td>0</td> <td>2,537</td> <td>209.00</td> </tr> <tr> <td>2021</td> <td>2021-300002502</td> <td>ROBERTSON, MICHAEL G.</td> <td>102</td> <td>28,697</td> <td>0</td> <td>3,443</td> <td>284.00</td> </tr> <tr> <td>2020</td> <td>2020-300002502</td> <td>ROBERTSON, MICHAEL G.</td> <td>102</td> <td>28,697</td> <td>0</td> <td>3,443</td> <td>283.00</td> </tr> <tr> <td>2019</td> <td>2019-0002502</td> <td>ROBERTSON, MICHAEL G.</td> <td>102</td> <td>28,697</td> <td></td> <td>3,443</td> <td>285.00</td> </tr> <tr> <td>2018</td> <td>2018-0002502</td> <td>ROBERTSON, MICHAEL G.</td> <td>102</td> <td>28,697</td> <td></td> <td>3,443</td> <td>285.00</td> </tr> <tr> <td>2017</td> <td>2017-0002502</td> <td>ROBERTSON, MICHAEL G.</td> <td>102</td> <td>30,223</td> <td></td> <td>3,627</td> <td>302.00</td> </tr> <tr> <td>2016</td> <td>2016-0002502</td> <td>ROBERTSON, MICHAEL G.</td> <td>102</td> <td>29,899</td> <td></td> <td>3,588</td> <td>305.00</td> </tr> <tr> <td>2015</td> <td>2015-0002502</td> <td>ROBERTSON, MICHAEL G.</td> <td>102</td> <td>33,698</td> <td></td> <td>3,983</td> <td>316.00</td> </tr> <tr> <td>2014</td> <td>2014-0002502</td> <td>ROBERTSON, MICHAEL G.</td> <td>102</td> <td>32,224</td> <td></td> <td>3,867</td> <td>310.00</td> </tr> <tr> <td>2013</td> <td>2013-0002502</td> <td>ROBERTSON, MICHAEL G.</td> <td>102</td> <td>38,000</td> <td></td> <td>4,560</td> <td>363.00</td> </tr> </tbody> </table> |                       |                        |              |             |  |   |            |         |           | Tax Year | Statement Number | Billed Owner | Tax Area   | Total Value | Exemptions          | Taxable Value         | Billed Tax   | 2025   | 2025-300002502 | THOMAS, JON DERICK AND | 102            | 27,337     | 0      | 2,936 | 231.00         | 2024                 | 2024-300002502 | ROBERTSON, MICHAEL G. | 102                | 29,358        | 0             | 2,797        | 228.00   | 2023 | 2023-300002502 | ROBERTSON, MICHAEL G. | 102    | 27,010 | 0               | 2,664        | 220.00         | 2022     | 2022-300002502   | ROBERTSON, MICHAEL G. | 102                  | 21,141       | 0 | 2,537 | 209.00 | 2021 | 2021-300002502 | ROBERTSON, MICHAEL G. | 102 | 28,697 | 0 | 3,443 | 284.00 | 2020 | 2020-300002502 | ROBERTSON, MICHAEL G. | 102 | 28,697 | 0 | 3,443 | 283.00 | 2019 | 2019-0002502 | ROBERTSON, MICHAEL G. | 102 | 28,697 |  | 3,443 | 285.00 | 2018 | 2018-0002502 | ROBERTSON, MICHAEL G. | 102 | 28,697 |  | 3,443 | 285.00 | 2017 | 2017-0002502 | ROBERTSON, MICHAEL G. | 102 | 30,223 |  | 3,627 | 302.00 | 2016 | 2016-0002502 | ROBERTSON, MICHAEL G. | 102 | 29,899 |  | 3,588 | 305.00 | 2015 | 2015-0002502 | ROBERTSON, MICHAEL G. | 102 | 33,698 |  | 3,983 | 316.00 | 2014 | 2014-0002502 | ROBERTSON, MICHAEL G. | 102 | 32,224 |  | 3,867 | 310.00 | 2013 | 2013-0002502 | ROBERTSON, MICHAEL G. | 102 | 38,000 |  | 4,560 | 363.00 |
| Tax Year  | Statement Number      | Billed Owner           | Tax Area     | Total Value | Exemptions   | Taxable Value   | Billed Tax |         |           |          |                  |              |            |             |                     |                       |              |        |                |                        |                |            |        |       |                |                      |                |                       |                    |               |               |              |  |      |                |                       |        |        |                 |              |                |          |                  |                       |                      |              |   |       |        |      |                |                       |     |        |   |       |        |      |                |                       |     |        |   |       |        |      |              |                       |     |        |  |       |        |      |              |                       |     |        |  |       |        |      |              |                       |     |        |  |       |        |      |              |                       |     |        |  |       |        |      |              |                       |     |        |  |       |        |      |              |                       |     |        |  |       |        |      |              |                       |     |        |  |       |        |
| 2025  | 2025-300002502        | THOMAS, JON DERICK AND | 102          | 27,337      | 0  | 2,936   | 231.00     |         |           |          |                  |              |            |             |                     |                       |              |        |                |                        |                |            |        |       |                |                      |                |                       |                    |               |               |              |  |      |                |                       |        |        |                 |              |                |          |                  |                       |                      |              |   |       |        |      |                |                       |     |        |   |       |        |      |                |                       |     |        |   |       |        |      |              |                       |     |        |  |       |        |      |              |                       |     |        |  |       |        |      |              |                       |     |        |  |       |        |      |              |                       |     |        |  |       |        |      |              |                       |     |        |  |       |        |      |              |                       |     |        |  |       |        |      |              |                       |     |        |  |       |        |
| 2024  | 2024-300002502        | ROBERTSON, MICHAEL G.  | 102          | 29,358      | 0  | 2,797   | 228.00     |         |           |          |                  |              |            |             |                     |                       |              |        |                |                        |                |            |        |       |                |                      |                |                       |                    |               |               |              |  |      |                |                       |        |        |                 |              |                |          |                  |                       |                      |              |   |       |        |      |                |                       |     |        |   |       |        |      |                |                       |     |        |   |       |        |      |              |                       |     |        |  |       |        |      |              |                       |     |        |  |       |        |      |              |                       |     |        |  |       |        |      |              |                       |     |        |  |       |        |      |              |                       |     |        |  |       |        |      |              |                       |     |        |  |       |        |      |              |                       |     |        |  |       |        |
| 2023  | 2023-300002502        | ROBERTSON, MICHAEL G.  | 102          | 27,010      | 0  | 2,664   | 220.00     |         |           |          |                  |              |            |             |                     |                       |              |        |                |                        |                |            |        |       |                |                      |                |                       |                    |               |               |              |  |      |                |                       |        |        |                 |              |                |          |                  |                       |                      |              |   |       |        |      |                |                       |     |        |   |       |        |      |                |                       |     |        |   |       |        |      |              |                       |     |        |  |       |        |      |              |                       |     |        |  |       |        |      |              |                       |     |        |  |       |        |      |              |                       |     |        |  |       |        |      |              |                       |     |        |  |       |        |      |              |                       |     |        |  |       |        |      |              |                       |     |        |  |       |        |
| 2022  | 2022-300002502        | ROBERTSON, MICHAEL G.  | 102          | 21,141      | 0  | 2,537   | 209.00     |         |           |          |                  |              |            |             |                     |                       |              |        |                |                        |                |            |        |       |                |                      |                |                       |                    |               |               |              |  |      |                |                       |        |        |                 |              |                |          |                  |                       |                      |              |   |       |        |      |                |                       |     |        |   |       |        |      |                |                       |     |        |   |       |        |      |              |                       |     |        |  |       |        |      |              |                       |     |        |  |       |        |      |              |                       |     |        |  |       |        |      |              |                       |     |        |  |       |        |      |              |                       |     |        |  |       |        |      |              |                       |     |        |  |       |        |      |              |                       |     |        |  |       |        |
| 2021  | 2021-300002502        | ROBERTSON, MICHAEL G.  | 102          | 28,697      | 0  | 3,443   | 284.00     |         |           |          |                  |              |            |             |                     |                       |              |        |                |                        |                |            |        |       |                |                      |                |                       |                    |               |               |              |  |      |                |                       |        |        |                 |              |                |          |                  |                       |                      |              |   |       |        |      |                |                       |     |        |   |       |        |      |                |                       |     |        |   |       |        |      |              |                       |     |        |  |       |        |      |              |                       |     |        |  |       |        |      |              |                       |     |        |  |       |        |      |              |                       |     |        |  |       |        |      |              |                       |     |        |  |       |        |      |              |                       |     |        |  |       |        |      |              |                       |     |        |  |       |        |
| 2020  | 2020-300002502        | ROBERTSON, MICHAEL G.  | 102          | 28,697      | 0  | 3,443   | 283.00     |         |           |          |                  |              |            |             |                     |                       |              |        |                |                        |                |            |        |       |                |                      |                |                       |                    |               |               |              |  |      |                |                       |        |        |                 |              |                |          |                  |                       |                      |              |   |       |        |      |                |                       |     |        |   |       |        |      |                |                       |     |        |   |       |        |      |              |                       |     |        |  |       |        |      |              |                       |     |        |  |       |        |      |              |                       |     |        |  |       |        |      |              |                       |     |        |  |       |        |      |              |                       |     |        |  |       |        |      |              |                       |     |        |  |       |        |      |              |                       |     |        |  |       |        |
| 2019  | 2019-0002502          | ROBERTSON, MICHAEL G.  | 102          | 28,697      |  | 3,443   | 285.00     |         |           |          |                  |              |            |             |                     |                       |              |        |                |                        |                |            |        |       |                |                      |                |                       |                    |               |               |              |  |      |                |                       |        |        |                 |              |                |          |                  |                       |                      |              |   |       |        |      |                |                       |     |        |   |       |        |      |                |                       |     |        |   |       |        |      |              |                       |     |        |  |       |        |      |              |                       |     |        |  |       |        |      |              |                       |     |        |  |       |        |      |              |                       |     |        |  |       |        |      |              |                       |     |        |  |       |        |      |              |                       |     |        |  |       |        |      |              |                       |     |        |  |       |        |
| 2018  | 2018-0002502          | ROBERTSON, MICHAEL G.  | 102          | 28,697      |  | 3,443   | 285.00     |         |           |          |                  |              |            |             |                     |                       |              |        |                |                        |                |            |        |       |                |                      |                |                       |                    |               |               |              |  |      |                |                       |        |        |                 |              |                |          |                  |                       |                      |              |   |       |        |      |                |                       |     |        |   |       |        |      |                |                       |     |        |   |       |        |      |              |                       |     |        |  |       |        |      |              |                       |     |        |  |       |        |      |              |                       |     |        |  |       |        |      |              |                       |     |        |  |       |        |      |              |                       |     |        |  |       |        |      |              |                       |     |        |  |       |        |      |              |                       |     |        |  |       |        |
| 2017  | 2017-0002502          | ROBERTSON, MICHAEL G.  | 102          | 30,223      |  | 3,627   | 302.00     |         |           |          |                  |              |            |             |                     |                       |              |        |                |                        |                |            |        |       |                |                      |                |                       |                    |               |               |              |  |      |                |                       |        |        |                 |              |                |          |                  |                       |                      |              |   |       |        |      |                |                       |     |        |   |       |        |      |                |                       |     |        |   |       |        |      |              |                       |     |        |  |       |        |      |              |                       |     |        |  |       |        |      |              |                       |     |        |  |       |        |      |              |                       |     |        |  |       |        |      |              |                       |     |        |  |       |        |      |              |                       |     |        |  |       |        |      |              |                       |     |        |  |       |        |
| 2016  | 2016-0002502          | ROBERTSON, MICHAEL G.  | 102          | 29,899      |  | 3,588   | 305.00     |         |           |          |                  |              |            |             |                     |                       |              |        |                |                        |                |            |        |       |                |                      |                |                       |                    |               |               |              |  |      |                |                       |        |        |                 |              |                |          |                  |                       |                      |              |   |       |        |      |                |                       |     |        |   |       |        |      |                |                       |     |        |   |       |        |      |              |                       |     |        |  |       |        |      |              |                       |     |        |  |       |        |      |              |                       |     |        |  |       |        |      |              |                       |     |        |  |       |        |      |              |                       |     |        |  |       |        |      |              |                       |     |        |  |       |        |      |              |                       |     |        |  |       |        |
| 2015  | 2015-0002502          | ROBERTSON, MICHAEL G.  | 102          | 33,698      |  | 3,983   | 316.00     |         |           |          |                  |              |            |             |                     |                       |              |        |                |                        |                |            |        |       |                |                      |                |                       |                    |               |               |              |  |      |                |                       |        |        |                 |              |                |          |                  |                       |                      |              |   |       |        |      |                |                       |     |        |   |       |        |      |                |                       |     |        |   |       |        |      |              |                       |     |        |  |       |        |      |              |                       |     |        |  |       |        |      |              |                       |     |        |  |       |        |      |              |                       |     |        |  |       |        |      |              |                       |     |        |  |       |        |      |              |                       |     |        |  |       |        |      |              |                       |     |        |  |       |        |
| 2014  | 2014-0002502          | ROBERTSON, MICHAEL G.  | 102          | 32,224      |  | 3,867   | 310.00     |         |           |          |                  |              |            |             |                     |                       |              |        |                |                        |                |            |        |       |                |                      |                |                       |                    |               |               |              |  |      |                |                       |        |        |                 |              |                |          |                  |                       |                      |              |   |       |        |      |                |                       |     |        |   |       |        |      |                |                       |     |        |   |       |        |      |              |                       |     |        |  |       |        |      |              |                       |     |        |  |       |        |      |              |                       |     |        |  |       |        |      |              |                       |     |        |  |       |        |      |              |                       |     |        |  |       |        |      |              |                       |     |        |  |       |        |      |              |                       |     |        |  |       |        |
| 2013  | 2013-0002502          | ROBERTSON, MICHAEL G.  | 102          | 38,000      |  | 4,560   | 363.00     |         |           |          |                  |              |            |             |                     |                       |              |        |                |                        |                |            |        |       |                |                      |                |                       |                    |               |               |              |  |      |                |                       |        |        |                 |              |                |          |                  |                       |                      |              |   |       |        |      |                |                       |     |        |   |       |        |      |                |                       |     |        |   |       |        |      |              |                       |     |        |  |       |        |      |              |                       |     |        |  |       |        |      |              |                       |     |        |  |       |        |      |              |                       |     |        |  |       |        |      |              |                       |     |        |  |       |        |      |              |                       |     |        |  |       |        |      |              |                       |     |        |  |       |        |



# Harper

## Assessment Property Record Card for Tax Year 2026

Data provided by SHAYLYN WEDER County Assessor

Date 02/06/2026  
 Time 06:26:11  
 Page 2

| Lot Data  | Acre - HomeSite and Tracts | Primary Image   |
|---|----------------------------|---|
| Lot Size<br>Lot Count<br>Units Buildable<br>Non-Ag Acres 3.68<br>Topography<br>Street Access<br>Utilities<br>Amenities<br><br>Method Acre<br>Base Lot Value 3.68 x 1,904.89 = 7,010<br>Factor Value<br>Adjustments<br>Lot Value 7,010 |                            |  <p>0000-12-27N-23W-3-003-00 06/11/24</p> |

| Residential Data |                           |
|------------------|---------------------------|
| Type             | 1 Single Family Residence |
| Condition        | 1 - Low                   |
| Quality          | 1 - Low                   |
| Architecture     | TRAD TRADITIONAL          |
| Style            | 100% One Story            |
| Exterior Wall    | 100% Frame, Siding, Vinyl |
| Base/Total Area  | 1,080 / 1,080             |
| Style            | 100% One Story            |
| HVAC             |                           |
| Roof Cover       | 1 Composition Shingle     |
| Area on Slab     | 0                         |
| Fixture/RghIn    | 5 /                       |
| Bed/F/H Bath     | 2 / 1.0 /                 |
| Basement Area    |                           |
| Garage Type      |                           |
| Remodel          |                           |
| Year/Eff Age     | 1947 / 111                |

HOUSE 6/12/2024

| GRM Approach    |  |
|-----------------|--|
| GRM Code        |  |
| Gross Rent      |  |
| Indicated Value |  |

| Multiple Regression |  |
|---------------------|--|
| MRA Code            |  |
| Adjusted R          |  |
| Indicated Value     |  |

| Direct Comparables |         |                           |
|--------------------|---------|---------------------------|
| Selection Model    | DEFAULT | DEFAULT SELECTION MODEL   |
| Adjustment Model   | DEFAULT | DEFAULT ADJUSTMENTS TABLE |
| Comparables        |         |                           |
| Indicated Value    |         |                           |

| Cost Approach |          | Manual :            |           |
|---------------|----------|---------------------|-----------|
| Base Cost     | 67.85    | Total Misc Impr     | + 18,917  |
| Roofing Adj   | + 3.26   | Garage Cost         | + 0       |
| Subfloor Adj  | + 2.07   | Total RCN           | = 102,725 |
| Heat/Cool Adj | + 0.00   | Depreciation ( 80%) | - 82,180  |
| Plumbing Adj  | + 4.43   | Lump Sums           | + 0       |
| Basement Adj  | + 0.00   | RCNLD               | = 20,545  |
| Adj Base Cost | = 77.60  | Lot Value           | + 7,010   |
| Total Area    | x 1,080  | Indicated Value     | = 27,555  |
| Adjusted Cost | = 83,808 | Value Per SqFt      | 25.51     |

| Value Reconciliation |               |       |                      |
|----------------------|---------------|-------|----------------------|
| Selected Approach    | Cost Approach |       |                      |
| Improvements         | 20,545        |       |                      |
| Lot Value            | 7,010         |       |                      |
| Indicated Value      | 27,555        | 25.51 | Per SqFt             |
| Agland Value         |               |       |                      |
| Site Improvements    | 8,033         |       |                      |
| Total Value          | 35,588        | 32.95 | Total Value Per SqFt |

| Miscellaneous Improvements |                   |           |      |      |       |           |      |        |
|----------------------------|-------------------|-----------|------|------|-------|-----------|------|--------|
| Code                       | Description       | Sketch ID | Size | Year | Units | Unit Cost | Depr | Value  |
| SHDS                       | Yard Shed - Wood  | 1328      | 530  |      | 530   | 11.91     |      | 6,312  |
| SHDS                       | Yard Shed - Wood  | 1329      | 1008 |      | 1,008 | 11.91     |      | 12,005 |
| PATO                       | Slab Porch - Open | 1330      | 11x7 |      | 77    | 7.79      |      | 600    |



Harper

Assessment Property Record Card for Tax Year 2026

Data provided by SHAYLYN WEDER County Assessor

Date 02/06/2026

Time 06:26:11

Page 3

Sketch Image

300002502

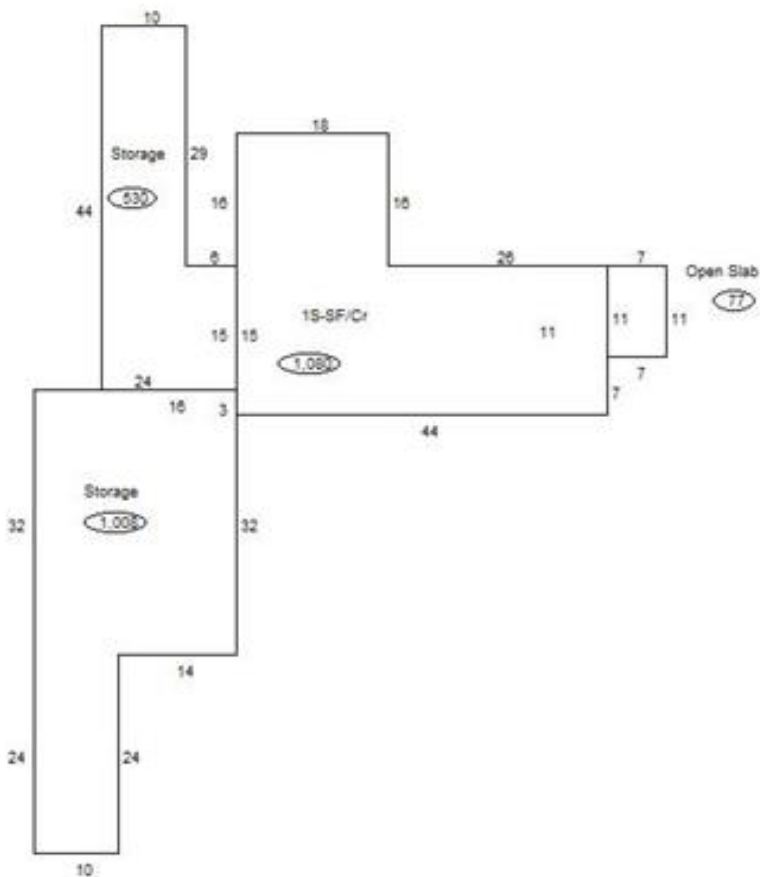

Sketch Vector Information

| Sequence                   | Code | Type | Built Over | Scale | Section Label | Base Area    | Multiplier | Total Area   |
|----------------------------|------|------|------------|-------|---------------|--------------|------------|--------------|
| 1                          | R    | 1    | Crawl      | 20    | 1S-SF/Cr      | 1,080        | 1.000      | 1,080        |
| 2                          | M    | SHDS |            | 20    | Storage       | 530          | 1.000      | 530          |
| 3                          | M    | SHDS |            | 20    | Storage       | 1,008        | 1.000      | 1,008        |
| 4                          | M    | PATO |            | 20    | Open Slab     | 77           | 1.000      | 77           |
| <b>Total Building Area</b> |      |      |            |       |               | <b>1,080</b> |            | <b>1,080</b> |



# Harper

## Assessment Property Record Card for Tax Year 2026

Data provided by SHAYLYN WEDER County Assessor

Date 02/06/2026  
Time 06:26:11  
Page 4

300002502

### Outbuildings/Site Improvements

| Building Image | Code | Description         | Dimensions | Floor   | Roofing | Total Units |
|----------------|------|---------------------|------------|---------|---------|-------------|
|                | UHRV | Utility Hookup - RV | 0x0x0      |         |         | 3           |
|                | Qual | Cond                | Year       | Eff Age |         |             |

| Valuation Summary        |       | Modifier Total | RCN   | Depr (0% Phys/ % Func) | RCNLD |
|--------------------------|-------|----------------|-------|------------------------|-------|
| Base Cost (2,677.50 x 3) | 8,033 |                | 8,033 |                        | 8,033 |