



# Harper

## Assessment Property Record Card for Tax Year 2026

Data provided by SHAYLYN WEDER County Assessor

Date 02/06/2026  
 Time 06:33:34  
 Page 1

Assessment Data					Primary Image																																																																																																																			
<b>Account</b> 300003021 <b>Parcel ID</b> 0000-34-27N-26W-3-002-00 <b>Cadastral ID</b> 0000-27N-26W-34-3-002-00 <b>Property Type</b> REAL - Real Property <b>Property Class</b> RA VI Area 4 <b>Tax Area</b> 101 - 1R-LAVERNE <b>Name ID</b> 13648 MULBERRY, KENNETH KEITH TRUST MARY LU MULBERRY TRUST  1654 N 1705 RD LAVERNE OK 73848-5800  <b>Parcel Location</b> <b>Situs</b> 3427N26W32 <b>Subdivision</b> <b>Lot/Block</b> / <b>Parcel Size</b> 80 - Acres <b>Sec/Twn/Rng</b> 34 / 27 / 26 / 3 <b>Neighborhood</b> 1000 - COUNTY <b>School District</b> 1-LAVERN - 1-LAVERNE					 <p>0000-34-27N-26W-3-002-00_001.JPG 7/19/2022</p>																																																																																																																			
<b>Legal Description</b> Lat/Long: 36.72283492 -99.94749032 SEC. 34-27-26 E2SW4 KENNETH KEITH MULBERRY REV TR.;MARY LU MULBERRY REV TR. BOOK 548 PAGE 541																																																																																																																								
<b>Exemptions</b> <table border="1"> <thead> <tr> <th>Code</th> <th>Type</th> <th>Active</th> <th>Maximum</th> <th>Exemption</th> </tr> </thead> <tbody> <tr> <td>H</td> <td>Homestead</td> <td>Yes</td> <td>1,000</td> <td>1,000</td> </tr> </tbody> </table>					Code	Type	Active	Maximum	Exemption	H	Homestead	Yes	1,000	1,000	<b>Building Permits</b> <table border="1"> <thead> <tr> <th>Number</th> <th>Description</th> <th>Opened</th> <th>Closed</th> <th>Amount</th> </tr> </thead> <tbody> <tr> <td colspan="5"> </td> </tr> </tbody> </table>					Number	Description	Opened	Closed	Amount																																																																																																
Code	Type	Active	Maximum	Exemption																																																																																																																				
H	Homestead	Yes	1,000	1,000																																																																																																																				
Number	Description	Opened	Closed	Amount																																																																																																																				
<b>Parcel Valuation</b> <table border="1"> <thead> <tr> <th>Source</th> <th>REAL</th> <th>Fair Cash</th> <th>Capped</th> <th>Asmnt Level</th> <th>Assessed</th> <th>Levy Rate</th> <th>67.190</th> <th>Current Tax</th> </tr> </thead> <tbody> <tr> <td>Remove Cap</td> <td></td> <td>Land Value</td> <td>11,928</td> <td>11,928</td> <td>12%</td> <td>1,431</td> <td>Assessed</td> <td>16,286 1,094.26</td> </tr> <tr> <td>Year Frozen</td> <td></td> <td>Improvements</td> <td>123,788</td> <td>123,788</td> <td></td> <td>14,855</td> <td>Penalty</td> <td>0</td> </tr> <tr> <td>Uncapped Value</td> <td>0</td> <td>Mobile Home</td> <td>0</td> <td>0</td> <td></td> <td>0</td> <td>Exemption</td> <td>1,000 -67.00</td> </tr> <tr> <td>TIF Project ID</td> <td>0</td> <td>Total Value</td> <td>135,716</td> <td>135,716</td> <td></td> <td>16,286</td> <td>Total Taxable</td> <td>15,286 1,027.00</td> </tr> </tbody> </table>					Source	REAL	Fair Cash	Capped	Asmnt Level	Assessed	Levy Rate	67.190	Current Tax	Remove Cap		Land Value	11,928	11,928	12%	1,431	Assessed	16,286 1,094.26	Year Frozen		Improvements	123,788	123,788		14,855	Penalty	0	Uncapped Value	0	Mobile Home	0	0		0	Exemption	1,000 -67.00	TIF Project ID	0	Total Value	135,716	135,716		16,286	Total Taxable	15,286 1,027.00	<b>Sale History</b> <table border="1"> <thead> <tr> <th>Bk/Pg</th> <th>Grantor</th> <th>Date</th> <th>Price</th> <th>Code</th> </tr> </thead> <tbody> <tr> <td colspan="5"> </td> </tr> </tbody> </table>					Bk/Pg	Grantor	Date	Price	Code																																																													
Source	REAL	Fair Cash	Capped	Asmnt Level	Assessed	Levy Rate	67.190	Current Tax																																																																																																																
Remove Cap		Land Value	11,928	11,928	12%	1,431	Assessed	16,286 1,094.26																																																																																																																
Year Frozen		Improvements	123,788	123,788		14,855	Penalty	0																																																																																																																
Uncapped Value	0	Mobile Home	0	0		0	Exemption	1,000 -67.00																																																																																																																
TIF Project ID	0	Total Value	135,716	135,716		16,286	Total Taxable	15,286 1,027.00																																																																																																																
Bk/Pg	Grantor	Date	Price	Code																																																																																																																				
<b>Assessment History</b> <table border="1"> <thead> <tr> <th>Tax Year</th> <th>Statement Number</th> <th>Billed Owner</th> <th>Tax Area</th> <th>Total Value</th> <th>Exemptions</th> <th>Taxable Value</th> <th>Billed Tax</th> </tr> </thead> <tbody> <tr><td>2025</td><td>2025-300003021</td><td>MULBERRY, KENNETH KEITH TRUST</td><td>101</td><td>135,716</td><td>1000</td><td>15,051</td><td>1,011.00</td></tr> <tr><td>2024</td><td>2024-300003021</td><td>MULBERRY, KENNETH KEITH TRUST</td><td>101</td><td>141,957</td><td>1000</td><td>14,584</td><td>970.00</td></tr> <tr><td>2023</td><td>2023-300003021</td><td>MULBERRY, KENNETH KEITH TRUST</td><td>101</td><td>126,081</td><td>1000</td><td>14,130</td><td>949.00</td></tr> <tr><td>2022</td><td>2022-300003021</td><td>MULBERRY, KENNETH, (TRUST)</td><td>101</td><td>124,054</td><td>1000</td><td>13,808</td><td>935.00</td></tr> <tr><td>2021</td><td>2021-300003021</td><td>MULBERRY, KENNETH, (TRUST)</td><td>101</td><td>124,054</td><td>1000</td><td>13,377</td><td>924.00</td></tr> <tr><td>2020</td><td>2020-300003021</td><td>MULBERRY, KENNETH, (TRUST)</td><td>101</td><td>124,054</td><td>1000</td><td>12,958</td><td>878.00</td></tr> <tr><td>2019</td><td>2019-0003021</td><td>MULBERRY, KENNETH, (TRUST)</td><td>101</td><td>126,165</td><td></td><td>12,552</td><td>749.00</td></tr> <tr><td>2018</td><td>2018-0003021</td><td>MULBERRY, KENNETH, (TRUST)</td><td>101</td><td>127,568</td><td></td><td>12,157</td><td>726.00</td></tr> <tr><td>2017</td><td>2017-0003021</td><td>MULBERRY, KENNETH, (TRUST)</td><td>101</td><td>123,183</td><td></td><td>11,773</td><td>703.00</td></tr> <tr><td>2016</td><td>2016-0003021</td><td>MULBERRY, KENNETH, (TRUST)</td><td>101</td><td>125,132</td><td></td><td>11,401</td><td>680.00</td></tr> <tr><td>2015</td><td>2015-0003021</td><td>MULBERRY, KENNETH, (TRUST)</td><td>101</td><td>123,429</td><td></td><td>11,041</td><td>659.00</td></tr> <tr><td>2014</td><td>2014-0003021</td><td>MULBERRY, KENNETH, (TRUST)</td><td>101</td><td>117,413</td><td></td><td>10,690</td><td>638.00</td></tr> <tr><td>2013</td><td>2013-0003021</td><td>MULBERRY, KENNETH, (TRUST)</td><td>101</td><td>119,144</td><td></td><td>10,349</td><td>618.00</td></tr> </tbody> </table>									Tax Year	Statement Number	Billed Owner	Tax Area	Total Value	Exemptions	Taxable Value	Billed Tax	2025	2025-300003021	MULBERRY, KENNETH KEITH TRUST	101	135,716	1000	15,051	1,011.00	2024	2024-300003021	MULBERRY, KENNETH KEITH TRUST	101	141,957	1000	14,584	970.00	2023	2023-300003021	MULBERRY, KENNETH KEITH TRUST	101	126,081	1000	14,130	949.00	2022	2022-300003021	MULBERRY, KENNETH, (TRUST)	101	124,054	1000	13,808	935.00	2021	2021-300003021	MULBERRY, KENNETH, (TRUST)	101	124,054	1000	13,377	924.00	2020	2020-300003021	MULBERRY, KENNETH, (TRUST)	101	124,054	1000	12,958	878.00	2019	2019-0003021	MULBERRY, KENNETH, (TRUST)	101	126,165		12,552	749.00	2018	2018-0003021	MULBERRY, KENNETH, (TRUST)	101	127,568		12,157	726.00	2017	2017-0003021	MULBERRY, KENNETH, (TRUST)	101	123,183		11,773	703.00	2016	2016-0003021	MULBERRY, KENNETH, (TRUST)	101	125,132		11,401	680.00	2015	2015-0003021	MULBERRY, KENNETH, (TRUST)	101	123,429		11,041	659.00	2014	2014-0003021	MULBERRY, KENNETH, (TRUST)	101	117,413		10,690	638.00	2013	2013-0003021	MULBERRY, KENNETH, (TRUST)	101	119,144		10,349	618.00
Tax Year	Statement Number	Billed Owner	Tax Area	Total Value	Exemptions	Taxable Value	Billed Tax																																																																																																																	
2025	2025-300003021	MULBERRY, KENNETH KEITH TRUST	101	135,716	1000	15,051	1,011.00																																																																																																																	
2024	2024-300003021	MULBERRY, KENNETH KEITH TRUST	101	141,957	1000	14,584	970.00																																																																																																																	
2023	2023-300003021	MULBERRY, KENNETH KEITH TRUST	101	126,081	1000	14,130	949.00																																																																																																																	
2022	2022-300003021	MULBERRY, KENNETH, (TRUST)	101	124,054	1000	13,808	935.00																																																																																																																	
2021	2021-300003021	MULBERRY, KENNETH, (TRUST)	101	124,054	1000	13,377	924.00																																																																																																																	
2020	2020-300003021	MULBERRY, KENNETH, (TRUST)	101	124,054	1000	12,958	878.00																																																																																																																	
2019	2019-0003021	MULBERRY, KENNETH, (TRUST)	101	126,165		12,552	749.00																																																																																																																	
2018	2018-0003021	MULBERRY, KENNETH, (TRUST)	101	127,568		12,157	726.00																																																																																																																	
2017	2017-0003021	MULBERRY, KENNETH, (TRUST)	101	123,183		11,773	703.00																																																																																																																	
2016	2016-0003021	MULBERRY, KENNETH, (TRUST)	101	125,132		11,401	680.00																																																																																																																	
2015	2015-0003021	MULBERRY, KENNETH, (TRUST)	101	123,429		11,041	659.00																																																																																																																	
2014	2014-0003021	MULBERRY, KENNETH, (TRUST)	101	117,413		10,690	638.00																																																																																																																	
2013	2013-0003021	MULBERRY, KENNETH, (TRUST)	101	119,144		10,349	618.00																																																																																																																	



# Harper

## Assessment Property Record Card for Tax Year 2026

Data provided by SHAYLYN WEDER County Assessor

Date 02/06/2026  
 Time 06:33:34  
 Page 2

Lot Data	Acre - HomeSite and Tracts	Primary Image
Lot Size Lot Count Units Buildable Non-Ag Acres 0 Topography Street Access Utilities Amenities  Method Acre Base Lot Value .00 x .00 = 2,500 Factor Value Adjustments Lot Value 2,500		 <p>0000-34-27N-26W-3-002-00 07/15/22</p> <p>0000-34-27N-26W-3-002-00_001.JPG 7/19/2022</p>

Residential Data	
Type	1 Single Family Residence
Condition	2.5 - Fair
Quality	2.5 - Fair
Architecture	TRAD TRADITIONAL
Style	100% One Story
Exterior Wall	50% Veneer, Masonry 50% Frame, Siding, Vinyl
Base/Total Area	2,171 / 2,171
Style	100% One Story
HVAC	100% Warmed & Cooled Air
Roof Cover	4 Metal, Preformed
Area on Slab	0
Fixture/RghIn	8 /
Bed/F/H Bath	3 / 2.0 /
Basement Area	70 Total, 70 Partition
Garage Type	345 Attached Garage - Unfinished
Remodel	
Year/Eff Age	1970 / 62

GRM Approach
GRM Code
Gross Rent
Indicated Value

Multiple Regression
MRA Code
Adusted R
Indicated Value

Direct Comparables		
Selection Model	DEFAULT	DEFAULT SELECTION MODEL
Adjustment Model	DEFAULT	DEFAULT ADJUSTMENTS TABLE
Comparables		
Indicated Value		

Cost Approach		Manual :	
Base Cost	76.64	Total Misc Impr	+ 8,131
Roofing Adj	+ 3.99	Garage Cost	+ 8,956
Subfloor Adj	+ 0.88	Total RCN	= 227,783
Heat/Cool Adj	+ 9.78	Depreciation ( 66%)	- 150,337
Plumbing Adj	+ 4.10	Lump Sums	+ 0
Basement Adj	+ 1.67	RCNLD	= 77,446
Adj Base Cost	= 97.05	Lot Value	+ 2,500
Total Area	x 2,171	Indicated Value	= 79,946
Adjusted Cost	= 210,696	Value Per SqFt	36.82

Value Reconciliation			
Selected Approach	Cost Approach		
Improvements	77,446		
Lot Value	2,500		
Indicated Value	79,946	36.82	Per SqFt
Agland Value	9,428		
Site Improvements	43,523		
Total Value	132,897	61.21	Total Value Per SqFt

Miscellaneous Improvements								
Code	Description	Sketch ID	Size	Year	Units	Unit Cost	Depr	Value
FPR1	1 1st Msn Cls A	0		1	1	4,340.86		4,341
PATO	Raised Slab Porch - Open	1572	5x5		25	9.25		231
PATO	Raised Slab Porch - Open	1573	5x5		25	9.25		231
PATC	Patio - Covered	1574	18x4		72	16.18		1,165
EPSW	Enclosed Porch - Solid Wall	1577	8x5		40	54.07		2,163



Harper

Assessment Property Record Card for Tax Year 2026

Data provided by SHAYLYN WEDER County Assessor

Date 02/06/2026  
 Time 06:33:34  
 Page 3

Sketch Image

300003021

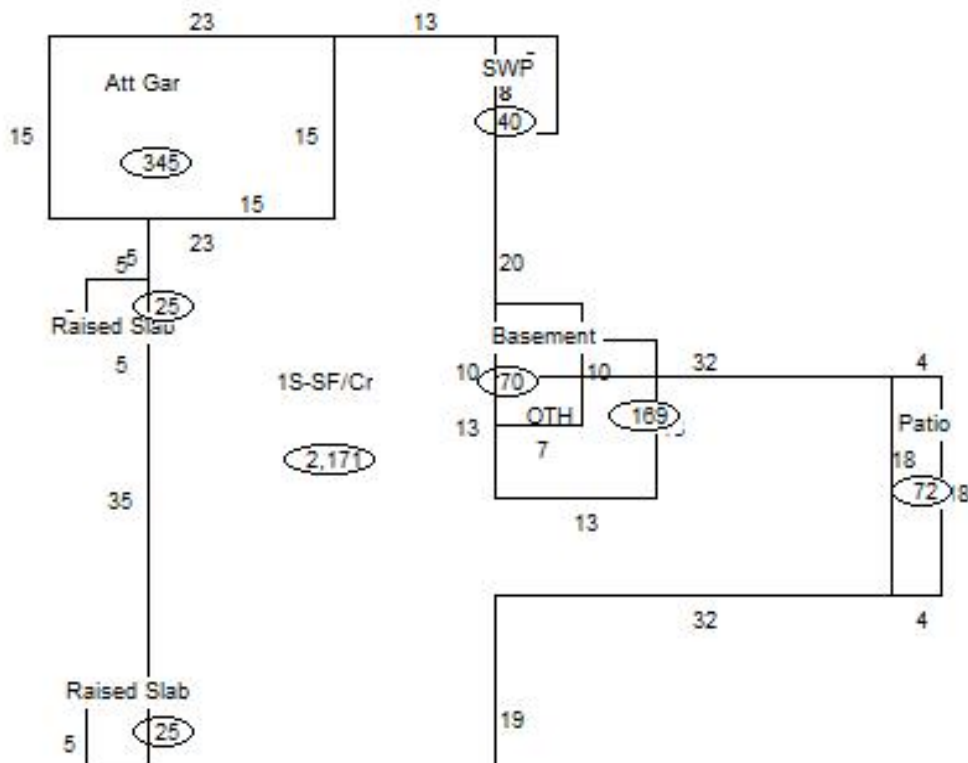

Sketch Vector Information

Sequence	Code	Type	Built Over	Scale	Section Label	Base Area	Multiplier	Total Area
1	R	1	Crawl	20	1S-SF/Cr	2,171	1.000	2,171
2	G	1		20	Att Gar	345	1.000	345
3	M	PATO		20	Raised Slab	25	1.000	25
4	M	PATO		20	Raised Slab	25	1.000	25
5	M	PATC		20	Patio	72	1.000	72
6	D	^DA		20	OTH	169	1.000	169
7	B			20	Basement	70	1.000	70
8	M	EPSW		20	SWP	40	1.000	40
<b>Total Building Area</b>						<b>2,171</b>		<b>2,171</b>



# Harper

## Assessment Property Record Card for Tax Year 2026

Data provided by SHAYLYN WEDER County Assessor

Date 02/06/2026  
Time 06:33:34  
Page 4

300003021

### Outbuildings/Site Improvements

Building Image	Code	Description	Dimensions	Floor	Roofing	Total Units		
	SHDS	Shipping/Storage Container	40x8x8			320		
	Qual	3	Cond	3	Year	2023	Eff Age	3
				0				
				0				
<b>Valuation Summary</b>		<b>Modifier Total</b>		<b>RCN</b>	<b>Depr (14% Phys/ % Func)</b>	<b>RCNLD</b>		
Base Cost (19.22 x 320)		6,150		6,150		861	5,289	
	GRDT	Garage - Detached	24x30x10		Formed Metal	720		
	Qual	3	Cond	3	Year	2003	Eff Age	23
				0				
				0				
<b>Valuation Summary</b>		<b>Modifier Total</b>		<b>RCN</b>	<b>Depr (52% Phys/ % Func)</b>	<b>RCNLD</b>		
Base Cost (33.14 x 720)		23,861		23,861		12,408	11,453	
	UTIL	Utility Building	40x60x14		Formed Metal	2,400		
	Qual	3	Cond	3	Year	1980	Eff Age	46
				0				
				0				
<b>Valuation Summary</b>		<b>Modifier Total</b>		<b>RCN</b>	<b>Depr (69% Phys/ % Func)</b>	<b>RCNLD</b>		
Base Cost (23.07 x 2,400)		55,368		55,368		38,204	17,164	
	GBST	Grain Bin - Storage 2,200 BU	0x0x0			2,200		
	Qual	3	Cond	3	Year	1980	Eff Age	46
				0				
				0				
<b>Valuation Summary</b>		<b>Modifier Total</b>		<b>RCN</b>	<b>Depr (80% Phys/ % Func)</b>	<b>RCNLD</b>		
Base Cost (1.62 x 2,200)		3,564		3,564		2,851	713	
	SHDS	Yard Shed - Metal	0x0x0		Formed Metal	64		
	Qual	3	Cond	3	Year	1980	Eff Age	46
				0				
				0				
<b>Valuation Summary</b>		<b>Modifier Total</b>		<b>RCN</b>	<b>Depr (80% Phys/ % Func)</b>	<b>RCNLD</b>		
Base Cost (28.41 x 64)		1,818		1,818		1,454	364	
	SCTR	Out Building 30 TON SCALE	0x0x0			34		
	Qual	3	Cond	3	Year	1980	Eff Age	46
				0				
				0				
<b>Valuation Summary</b>		<b>Modifier Total</b>		<b>RCN</b>	<b>Depr (69% Phys/ % Func)</b>	<b>RCNLD</b>		
Base Cost (810.23 x 34)		27,548		27,548		19,008	8,540	



# Harper

## Assessment Property Record Card for Tax Year 2026

Data provided by SHAYLYN WEDER County Assessor

Date 02/06/2026

Time 06:33:34

Page 5

### Agland Inventory

300003021

Soi	Description	Land Use	LPI	Adj Type	Adj Code	Acres	Use/Acre	Mkt/Acre	Use Value	Market Value
MG	MANSKER-POTTER 5-20%	CR	15			.101	76	76	8	8
MG	MANSKER-POTTER 5-20%	IP	15			28.250	59	59	1,670	1,670
MG	MANSKER-POTTER 5-20%	NP	15			.284	48	48	14	14
PA	PRATT BILLOWY	IP	48			8.102	189	189	1,532	1,532
PC	PRATT LOAMY BILLOWY	IP	37			42.212	146	146	6,154	6,154
PC	PRATT LOAMY BILLOWY	NP	37			.031	118	118	4	4
PD	PRATT LOAMY HUMMOCKY	IP	31			.031	122	122	4	4
QA	QUINLAN LOAM	IP	11			.932	43	43	40	40
QA	QUINLAN LOAM	NP	11			.057	35	35	2	2
<b>NP Totals</b>						80.000			9,428	9,428
<b>Total Agland</b>						80.000			9,428	9,428