



Harper

Assessment Property Record Card for Tax Year 2026

Data provided by SHAYLYN WEDER County Assessor

Date 02/06/2026
 Time 06:51:29
 Page 1

Assessment Data					Primary Image									
Account	300004327				<p>0000-27-29N-25W-3-001-00 06/16/25</p> <p>FRONT OF HOUSE 6/17/2025</p>									
Parcel ID	0000-27-29N-25W-3-001-00													
Cadastral ID	0000-29N-25W-27-3-001-00													
Property Type	REAL - Real Property													
Property Class	RA	VI Area	3											
Tax Area	101 - 1R-LAVERNE													
Name ID	14181													
LOTSPEICH, TROY, RV. LVNG TR (1/2EA)														
REBECCA LYNN LOTSPEICH RV. LVNG TR														
17615 E. 4 RD														
ROSSTON	OK 73855-0000													
Parcel Location														
Situs	17615 E 4 RD													
Subdivision														
Lot/Block	/	Parcel Size	42.86 - Acres											
Sec/Twn/Rng	27 / 29 / 25 / 3													
Neighborhood	1000 - COUNTY													
School District	1-LAVERNE - 1-LAVERNE													
Legal Description														
Lat/Long: 36.96057692 -99.89893920														
SEC.27-29-25 SW4SW4 BOOK 750 PAGE 467 UND 1/2 INT EA. BOOK 651 PAGE 598														
Building Permits														
<table border="1"> <thead> <tr> <th>Number</th> <th>Description</th> <th>Opened</th> <th>Closed</th> <th>Amount</th> </tr> </thead> <tbody> <tr> <td> </td> <td> </td> <td> </td> <td> </td> <td> </td> </tr> </tbody> </table>					Number	Description	Opened	Closed	Amount					
Number	Description	Opened	Closed	Amount										
Exemptions														
Code	Type	Active	Maximum	Exemption										
Sale History														
Bk/Pg	Grantor	Date	Price	Code										
750/467	GERALDINE, LLC, ETALS	02/10/2020	200,000	04										
651/598	WOLF CREEK ENTERPRISES, I	08/28/2009	109,500	05										
599/817	BANKRUPTCY ESTATE	01/28/2005	109,500	MU										
599/622	LOTSPEICH, R.A.	01/20/2005	109,500	MU										
Parcel Valuation														
Source	REAL	Fair Cash	Capped	Asmnt Level	Assessed	Levy Rate	67.190	Current Tax						
Remove Cap		Land Value	11,069	11,069	12%	1,328	Assessed	21,490	1,443.91					
Year Frozen		Improvements	184,204	168,017		20,162	Penalty	0						
Uncapped Value	0	Mobile Home	0	0		0	Exemption	0	0.00					
TIF Project ID	0	Total Value	195,273	179,086		21,490	Total Taxable	21,490	1,444.00					
Assessment History														
Tax Year	Statement Number	Billed Owner	Tax Area	Total Value	Exemptions	Taxable Value	Billed Tax							
2025	2025-300004327	LOTSPEICH, TROY, RV. LVNG TR (1/2EA)	101	195,273	0	20,864	1,402.00							
2024	2024-300004327	LOTSPEICH, TROY, RV. LVNG TR (1/2EA)	101	206,571	0	20,256	1,347.00							
2023	2023-300004327	LOTSPEICH, TROY, RV. LVNG TR (1/2EA)	101	190,444	0	19,667	1,321.00							
2022	2022-300004327	LOTSPEICH, TROY, RV. LVNG TR (1/2EA)	101	169,898	0	19,095	1,293.00							
2021	2021-300004327	LOTSPEICH, TROY, RV. LVNG TR &	101	154,483	0	18,538	1,280.00							
2020	2020-300004327	LOTSPEICH, TROY, RV. LVNG TR &	101	154,483	0	18,412	1,247.00							
2019	2019-0004327	GERALDINE, LLC, ETALS	101	154,003		17,809	1,063.00							
2018	2018-0004327	GERALDINE, LLC, ETALS	101	154,003		17,291	1,032.00							
2017	2017-0004327	GERALDINE, LLC, ETALS	101	147,363		16,788	1,002.00							
2016	2016-0004327	GERALDINE, LLC, ETALS	101	150,244		16,300	973.00							
2015	2015-0004327	GERALDINE, LLC, ETALS	101	144,563		15,824	944.00							
2014	2014-0004327	GERALDINE, LLC, ETALS	101	138,309		15,364	917.00							
2013	2013-0004327	GERALDINE, LLC, ETALS	101	157,749		14,916	890.00							



Harper

Assessment Property Record Card for Tax Year 2026

Data provided by SHAYLYN WEDER County Assessor

Date 02/06/2026
 Time 06:51:29
 Page 2

Lot Data	Acre - HomeSite and Tracts	Primary Image
Lot Size Lot Count Units Buildable Non-Ag Acres 1 Topography Street Access Utilities Amenities Method Acre Base Lot Value 1.00 x 5,000.00 = 5,000 Factor Value Adjustments Lot Value 5,000		<p>0000-27-29N-25W-3-001-00 06/16/25</p>

Residential Data	
Type	1 Single Family Residence
Condition	3 - Average
Quality	3 - Average
Architecture	TRAD TRADITIONAL
Style	100% One Story
Exterior Wall	100% Veneer, Masonry
Base/Total Area	3,122 / 3,122
Style	100% One Story
HVAC	100% Warmed & Cooled Air
Roof Cover	1 Composition Shingle
Area on Slab	0
Fixture/RghIn	8 /
Bed/F/H Bath	3 / 2.0 /
Basement Area	2,028 Total, 2,028 Partition
Garage Type	529 Built-In Garage
Remodel	
Year/Eff Age	1965 / 61

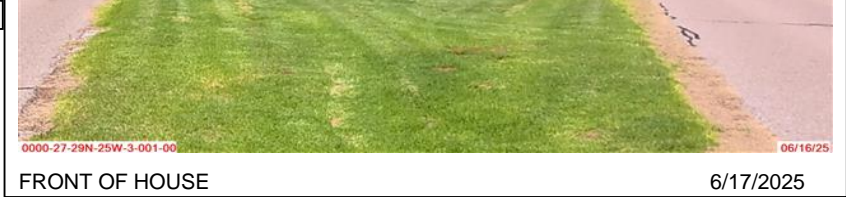

GRM Approach	
GRM Code	
Gross Rent	
Indicated Value	

Multiple Regression	
MRA Code	
Adjusted R	
Indicated Value	

Direct Comparables	
Selection Model	DEFAULT DEFAULT SELECTION MODEL
Adjustment Model	DEFAULT DEFAULT ADJUSTMENTS TABLE
Comparables	
Indicated Value	

Cost Approach		Manual :	
Base Cost	79.13	Total Misc Impr	+ 26,944
Roofing Adj	+ 3.46	Garage Cost	+ 12,105
Subfloor Adj	+ 0.00	Total RCN	= 422,337
Heat/Cool Adj	+ 10.77	Depreciation (63%)	- 266,072
Plumbing Adj	+ 3.15	Lump Sums	+ 0
Basement Adj	+ 26.26	RCNLD	= 156,265
Adj Base Cost	= 122.77	Lot Value	+ 5,000
Total Area	x 3,122	Indicated Value	= 161,265
Adjusted Cost	= 383,288	Value Per SqFt	51.65

Value Reconciliation			
Selected Approach	Cost Approach		
Improvements	156,265		
Lot Value	5,000		
Indicated Value	161,265	51.65	Per SqFt
Agland Value	6,069		
Site Improvements	32,816		
Total Value	200,150	64.11	Total Value Per SqFt

Miscellaneous Improvements								
Code	Description	Sketch ID	Size	Year	Units	Unit Cost	Depr	Value
EPKS	Enclosed Porch - Kneewall Screen	1995	36x23	1980	828	23.21		19,218
PRCH	Slab Porch - Covered	1996	351	1980	351	22.01		7,726



Harper

Assessment Property Record Card for Tax Year 2026

Data provided by SHAYLYN WEDER County Assessor

Date 02/06/2026
 Time 06:51:29
 Page 3

Sketch Image

300004327

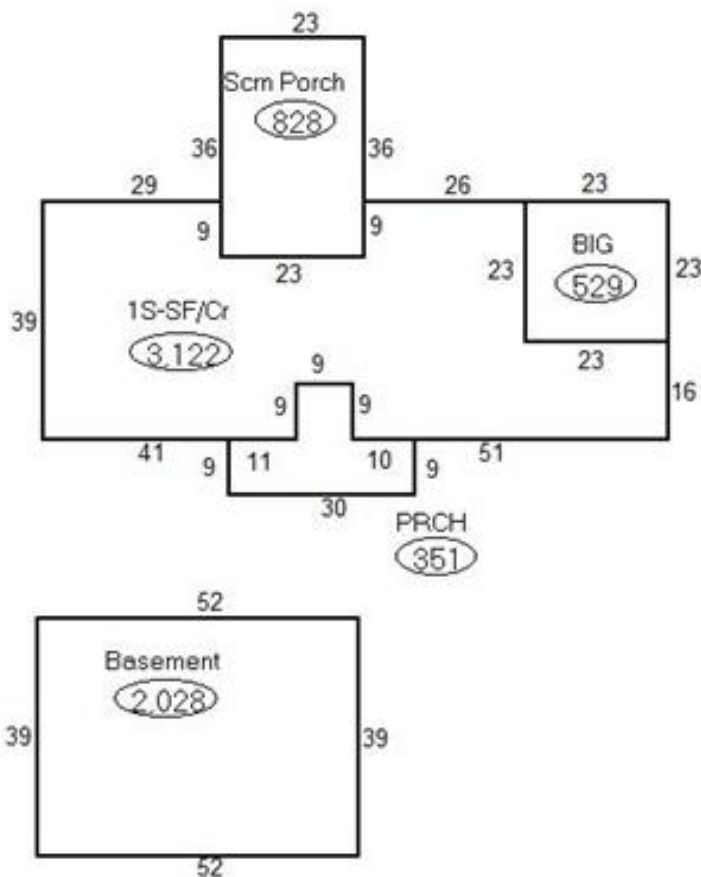

Sketch Vector Information

Sequence	Code	Type	Built Over	Scale	Section Label	Base Area	Multiplier	Total Area
1	M	EPKS		30	Scrm Porch	828	1.000	828
2	M	PRCH		30	PRCH	351	1.000	351
3	G	8		30	BIG	529	1.000	529
4	R	1	Crawl	30	1S-SF/Cr	3,122	1.000	3,122
5	B			30	Basement	2,028	1.000	2,028
Total Building Area						3,122		3,122



Harper

Assessment Property Record Card for Tax Year 2026

Data provided by SHAYLYN WEDER County Assessor

Date 02/06/2026
Time 06:51:29
Page 4

300004327

Outbuildings/Site Improvements

Building Image	Code	Description	Dimensions	Floor	Roofing	Total Units
	PAVA	Paving - Asphalt	711x12x0	Concrete		8,532
	Qual	3	Cond 3	Year 2000	Eff Age 26	
	Valuation Summary		Modifier Total	RCN	Depr (80% Phys/ % Func)	RCNLD
	Base Cost (2.38 x 8,532)		20,306	20,306	16,245	4,061
	SPLG	Swimming Pool - In Ground	17x34x0			578
	Qual	3	Cond 3	Year 1980	Eff Age 46	
	Valuation Summary		Modifier Total	RCN	Depr (80% Phys/ % Func)	RCNLD
	Base Cost (43.04 x 578)		24,877	24,877	19,902	4,975
	UTIL	Utility Bldg	24x54x0		Formed Metal	1,296
	Qual	3	Cond 3	Year 1970	Eff Age 56	
	Valuation Summary		Modifier Total	RCN	Depr (76% Phys/ % Func)	RCNLD
	Base Cost (26.72 x 1,296)		34,629	34,629	26,318	8,311
	SHDS	STG NEXT TO TENNIS COURT	14x12x0			168
	Qual	3	Cond 3	Year 1970	Eff Age 56	
	Valuation Summary		Modifier Total	RCN	Depr (80% Phys/ % Func)	RCNLD
	Base Cost (21.24 x 168)		3,568	3,568	2,854	714
	UTIL	Utility Building	34x42x0	Concrete	Galvanized Metal	1,428
	Qual	3	Cond 3	Year 1970	Eff Age 56	
	Valuation Summary		Modifier Total	RCN	Depr (76% Phys/ % Func)	RCNLD
	Base Cost (24.38 x 1,428)		34,815	34,815	26,459	8,356
	PACN	Tennis Court	112x51x0			5,712
	Qual	3	Cond 3	Year 1970	Eff Age 56	
	Valuation Summary		Modifier Total	RCN	Depr (80% Phys/ % Func)	RCNLD
	Base Cost (3.77 x 5,712)		21,534	21,534	17,227	4,307
	PATO	Patio - Open	45x14x0			630
	Qual	3	Cond 3	Year 1970	Eff Age 56	
	Valuation Summary		Modifier Total	RCN	Depr (80% Phys/ % Func)	RCNLD
	Base Cost (7.33 x 630)		4,618	4,618	3,694	924

0



Harper

Assessment Property Record Card for Tax Year 2026

Data provided by SHAYLYN WEDER County Assessor

Date 02/06/2026
Time 06:51:29
Page 5

300004327

Outbuildings/Site Improvements

Building Image	Code	Description	Dimensions	Floor	Roofing	Total Units
	PACN	Paving - Concrete Drive	28x52x0			1,456
	Qual 3	Cond 3	Year 1970	Eff Age 56		

Valuation Summary	Modifier Total	RCN	Depr (80% Phys/ % Func)	RCNLD
Base Cost (4.01 x 1,456)	5,839		5,839	4,671
				1,168



Harper

Assessment Property Record Card for Tax Year 2026

Data provided by SHAYLYN WEDER County Assessor

Date 02/06/2026
Time 06:51:29
Page 6

Agland Inventory

300004327

Soi	Description	Land Use	LPI	Adj Type	Adj Code	Acres	Use/Acre	Mkt/Acre	Use Value	Market Value
CA	CAREY SILT 1-3%	NP	50			29.670	160	160	4,747	4,747
SA	ST.PAUL 0-1%	NP	60			.376	192	192	72	72
SB	ST.PAUL 1-3%	NP	52			.043	166	166	7	7
WB	WOODWARD 3-8%	NP	33			11.770	106	106	1,243	1,243
NP Totals						41.860			6,069	6,069
Total Agland						41.860			6,069	6,069