



Harper

Assessment Property Record Card for Tax Year 2026

Data provided by SHAYLYN WEDER County Assessor

Date 02/06/2026
 Time 07:07:29
 Page 1

Assessment Data					Primary Image									
Account	300005471				 <p>1070-00-208-013-0-001-00 02/24/25</p>									
Parcel ID	1070-00-208-013-0-001-00													
Cadastral ID	1070-208-013-00-0-001-00													
Property Type	REAL - Real Property													
Property Class	UR	VI Area	3											
Tax Area	201 - 4T-BUFFALO-C													
Name ID	14753													
CENICEROS, IGNACIO & MARIA ESQUIVEL														
P O BOX 67 BUFFALO OK 73834-0000														
Parcel Location														
Situs	00409 NW FIRST ST													
Subdivision	MILLER'S ADDN													
Lot/Block	0013 / 0208	Parcel Size	2 - Lots											
Sec/Twn/Rng	/ / /													
Neighborhood	100100 - BUFFALO ORIG\MILLERS													
School District	4-BUFFAL - 4-BUFFALO													
Legal Description Lat/Long: 36.83044166 -99.62459048														
MILLERS ADD. BLOCK 208 LOTS W 100' OF 13-15-17														
Building Permits														
<table border="1"> <thead> <tr> <th>Number</th> <th>Description</th> <th>Opened</th> <th>Closed</th> <th>Amount</th> </tr> </thead> <tbody> <tr> <td> </td> <td> </td> <td> </td> <td> </td> <td> </td> </tr> </tbody> </table>					Number	Description	Opened	Closed	Amount					
Number	Description	Opened	Closed	Amount										
Exemptions														
Code	Type	Active	Maximum	Exemption										
Sale History														
Bk/Pg	Grantor	Date	Price	Code										
703/439	GADDIS, SAMUEL E.	11/24/2014	36,500	Q										
Parcel Valuation														
Source	REAL	Fair Cash	Capped	Asmnt Level	Assessed	Levy Rate	78.740	Current Tax						
Remove Cap		Land Value	2,250	2,250	12%	270	Assessed	5,735	451.57					
Year Frozen		Improvements	46,359	45,540		5,465	Penalty	0						
Uncapped Value	0	Mobile Home	0	0		0	Exemption	0	0.00					
TIF Project ID	0	Total Value	48,609	47,790		5,735	Total Taxable	5,735	452.00					
Assessment History														
Tax Year	Statement Number	Billed Owner	Tax Area	Total Value	Exemptions	Taxable Value	Billed Tax							
2025	2025-300005471	CENICEROS, IGNACIO &	201	48,609	0	5,462	430.00							
2024	2024-300005471	CENICEROS, IGNACIO &	201	52,360	0	5,202	424.00							
2023	2023-300005471	CENICEROS, IGNACIO &	201	49,669	0	4,954	410.00							
2022	2022-300005471	CENICEROS, IGNACIO &	201	43,239	0	4,718	388.00							
2021	2021-300005471	CENICEROS, IGNACIO &	201	37,447	0	4,494	371.00							
2020	2020-300005471	CENICEROS, IGNACIO &	201	37,447	0	4,494	370.00							
2019	2019-0005471	CENICEROS, IGNACIO &	201	37,447		4,494	372.00							
2018	2018-0005471	CENICEROS, IGNACIO &	201	37,447		4,380	363.00							
2017	2017-0005471	CENICEROS, IGNACIO &	201	37,447		4,052	337.00							
2016	2016-0005471	CENICEROS, IGNACIO &	201	37,447		3,859	328.00							
2015	2015-0005471	CENICEROS, IGNACIO &	201	36,500		3,676	292.00							
2014	2014-0005471	GADDIS, SAMUEL E.	201	37,586		3,501	281.00							
2013	2013-0005471	GADDIS, SAMUEL E.	201	49,333		3,334	266.00							



Harper

Assessment Property Record Card for Tax Year 2026

Data provided by SHAYLYN WEDER County Assessor

Date 02/06/2026
 Time 07:07:29
 Page 2

Lot Data	Square-Foot - BUFFALO ORIGMILLERS	Primary Image
Lot Size	75 x 100	
Lot Count		
Units Buildable	2250	
Non-Ag Acres		
Topography		
Street Access		
Utilities		
Amenities		
Method	Square-Foot	
Base Lot Value	7,500.00 x .30 = 2,250	
Factor Value		
Adjustments		
Lot Value	2,250	

Residential Data	
Type	1 Single Family Residence
Condition	2 - Fair
Quality	3 - Average
Architecture	TRAD TRADITIONAL
Style	100% One Story
Exterior Wall	100% Veneer, Masonry
Base/Total Area	1,484 / 1,484
Style	100% One Story
HVAC	100% Warmed & Cooled Air
Roof Cover	1 Composition Shingle
Area on Slab	1,484
Fixture/RghIn	5 /
Bed/F/H Bath	3 / 1.0 /
Basement Area	240 Total, 240 Partition
Garage Type	
Remodel	
Year/Eff Age	1960 / 79



FRONT OF HOUSE 2/24/2025

GRM Approach	
GRM Code	
Gross Rent	
Indicated Value	

Multiple Regression	
MRA Code	
Adjusted R	
Indicated Value	

Direct Comparables	
Selection Model	DEFAULT DEFAULT SELECTION MODEL
Adjustment Model	DEFAULT DEFAULT ADJUSTMENTS TABLE
Comparables	
Indicated Value	

Cost Approach		Manual :	
Base Cost	90.86	Total Misc Impr	+ 1,388
Roofing Adj	+ 3.97	Garage Cost	+
Subfloor Adj	+ -1.88	Total RCN	= 175,209
Heat/Cool Adj	+ 10.77	Depreciation (76%)	- 133,159
Plumbing Adj	+ 4.30	Lump Sums	+ 0
Basement Adj	+ 9.11	RCNLD	= 42,050
Adj Base Cost	= 117.13	Lot Value	+ 2,250
Total Area	x 1,484	Indicated Value	= 44,300
Adjusted Cost	= 173,821	Value Per SqFt	29.85

Value Reconciliation			
Selected Approach	Cost Approach		
Improvements	42,050		
Lot Value	2,250		
Indicated Value	44,300	29.85	Per SqFt
Agland Value			
Site Improvements	4,932		
Total Value	49,232	33.18	Total Value Per SqFt

Miscellaneous Improvements								
Code	Description	Sketch ID	Size	Year	Units	Unit Cost	Depr	Value
PATC	Patio - Covered	3581	12x6		72	17.11		1,232
PATO	Patio - Open	3582	4x4		16	9.78		156



Harper

Assessment Property Record Card for Tax Year 2026

Data provided by SHAYLYN WEDER County Assessor

Date 02/06/2026

Time 07:07:29

Page 3

Sketch Image

300005471

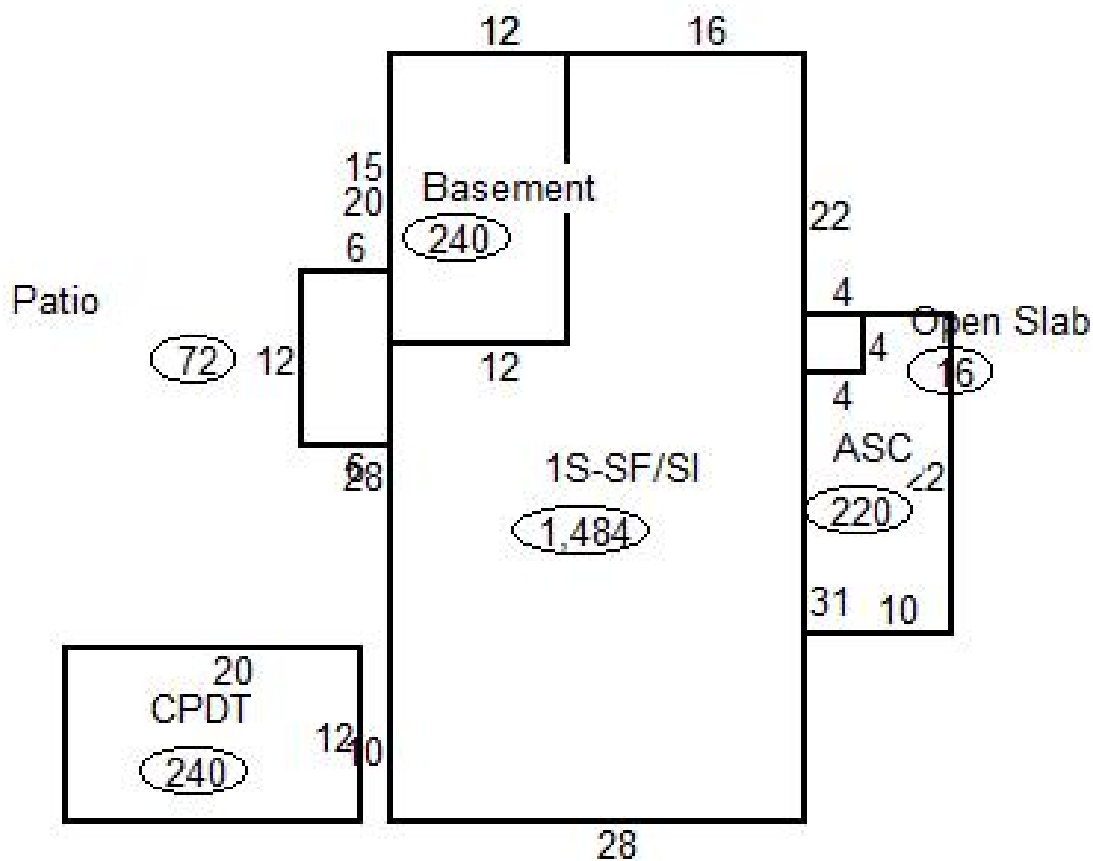

Sketch Vector Information

Sequence	Code	Type	Built Over	Scale	Section Label	Base Area	Multiplier	Total Area
1	B			20	Basement	240	1.000	240
2	M	PATC		20	Patio	72	1.000	72
3	M	PATO		20	Open Slab	16	1.000	16
4	R	1	Slab	20	1S-SF/Sl	1,484	1.000	1,484
5	O	CPDT		20	CPDT	240	1.000	240
6	O	ASC		20	ASC	220	1.000	220
Total Building Area						1,484		1,484



Harper





Assessment Property Record Card for Tax Year 2026

Data provided by SHAYLYN WEDER County Assessor

Date 02/06/2026
Time 07:07:29
Page 4

300005471

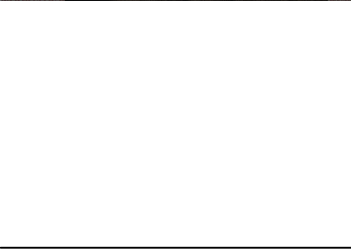
Outbuildings/Site Improvements

Building Image	Code	Description	Dimensions	Floor	Roofing	Total Units
	SHDS	Shed, Wood *replaced old shed	10x8x0	Base	Composition Shingle	80
	Qual	3	Cond 3	Year 2021	Eff Age 5	
Valuation Summary		Modifier Total	RCN	Depr (23% Phys/ 0% Func)		RCNLD
Base Cost (25.28 x 80)		2,022		2,022	465	1,557
	CPDT	Carport - Detached	20x12x8	Concrete	Formed Metal	240
	Qual	3	Cond 3	Year 2017	Eff Age 9	
Valuation Summary		Modifier Total	RCN	Depr (45% Phys/ 0% Func)		RCNLD
Base Cost (8.14 x 240)		1,954		1,954	879	1,075
	ASC	Awning/Shelter/Back of House	22x10x0		Formed Metal	220
	Qual	4	Cond 4	Year 2017	Eff Age 5	
Valuation Summary		Modifier Total	RCN	Depr (20% Phys/ 0% Func)		RCNLD
Base Cost (5.13 x 220)		1,129		1,129	226	903
	SHDS	Shed - Metal East*Roof 2017	8x12x0			96
	Qual	3	Cond 3	Year 2017	Eff Age 9	
Valuation Summary		Modifier Total	RCN	Depr (40% Phys/ 0% Func)		RCNLD
Base Cost (24.25 x 96)		2,328		2,328	931	1,397