



Harper

Assessment Property Record Card for Tax Year 2026

Data provided by SHAYLYN WEDER County Assessor

Date 02/06/2026
Time 07:17:36
Page 1

Assessment Data					Primary Image																																																																																																																				
Account 300006128 Parcel ID 2001-00-060-001-0-001-00 Cadastral ID 2001-060-001-00-0-001-00 Property Type REAL - Real Property Property Class UR VI Area 3 Tax Area 202 - 1T-LAVERNE-C Name ID 15200 KAY, COY, & LEORA KAY 17662 E 15 ROAD #80 ROSSTON OK 73855-0000 Parcel Location Situs 00224 N OKLAHOMA Subdivision LAVERNE ORIG. Lot/Block 0001 / 0060 Parcel Size 2 - Lots Sec/Twn/Rng / / / Neighborhood 200100 - LAVERNE ORIG\MULTI School District 1-LAVERN - 1-LAVERNE					 <p>FRONT OF HOUSE 4/23/2025</p>																																																																																																																				
Legal Description Lat/Long: 36.71253276 -99.89605749 LAVERNE ORIG BLOCK 60 LOTS N 90' OF 1-2-3																																																																																																																									
Exemptions <table border="1"> <thead> <tr> <th>Code</th> <th>Type</th> <th>Active</th> <th>Maximum</th> <th>Exemption</th> </tr> </thead> <tbody> <tr> <td></td> <td></td> <td></td> <td></td> <td></td> </tr> </tbody> </table>					Code	Type	Active	Maximum	Exemption						Building Permits <table border="1"> <thead> <tr> <th>Number</th> <th>Description</th> <th>Opened</th> <th>Closed</th> <th>Amount</th> </tr> </thead> <tbody> <tr> <td></td> <td></td> <td></td> <td></td> <td></td> </tr> </tbody> </table>					Number	Description	Opened	Closed	Amount																																																																																																	
Code	Type	Active	Maximum	Exemption																																																																																																																					
Number	Description	Opened	Closed	Amount																																																																																																																					
<table border="1"> <thead> <tr> <th>Code</th> <th>Type</th> <th>Active</th> <th>Maximum</th> <th>Exemption</th> </tr> </thead> <tbody> <tr> <td></td> <td></td> <td></td> <td></td> <td></td> </tr> </tbody> </table>					Code	Type	Active	Maximum	Exemption						Sale History <table border="1"> <thead> <tr> <th>Bk/Pg</th> <th>Grantor</th> <th>Date</th> <th>Price</th> <th>Code</th> </tr> </thead> <tbody> <tr> <td>681/4</td> <td>MCCOY, JAY D. AND (T</td> <td>05/16/2012</td> <td>9,000</td> <td>04</td> </tr> </tbody> </table>					Bk/Pg	Grantor	Date	Price	Code	681/4	MCCOY, JAY D. AND (T	05/16/2012	9,000	04																																																																																												
Code	Type	Active	Maximum	Exemption																																																																																																																					
Bk/Pg	Grantor	Date	Price	Code																																																																																																																					
681/4	MCCOY, JAY D. AND (T	05/16/2012	9,000	04																																																																																																																					
Parcel Valuation <table border="1"> <thead> <tr> <th>Source</th> <th>REAL</th> <th>Fair Cash</th> <th>Capped</th> <th>Asmnt Level</th> <th>Assessed</th> <th>Levy Rate</th> <th>67.190</th> <th>Current Tax</th> </tr> </thead> <tbody> <tr> <td>Remove Cap</td> <td></td> <td>2,700</td> <td>2,640</td> <td>12%</td> <td>317</td> <td>Assessed</td> <td>2,716</td> <td>182.49</td> </tr> <tr> <td>Year Frozen</td> <td></td> <td>27,010</td> <td>19,995</td> <td></td> <td>2,399</td> <td>Penalty</td> <td>0</td> <td></td> </tr> <tr> <td>Uncapped Value</td> <td>0</td> <td>0</td> <td>0</td> <td></td> <td>0</td> <td>Exemption</td> <td>0</td> <td>0.00</td> </tr> <tr> <td>TIF Project ID</td> <td>0</td> <td>29,710</td> <td>22,635</td> <td></td> <td>2,716</td> <td>Total Taxable</td> <td>2,716</td> <td>182.00</td> </tr> </tbody> </table>										Source	REAL	Fair Cash	Capped	Asmnt Level	Assessed	Levy Rate	67.190	Current Tax	Remove Cap		2,700	2,640	12%	317	Assessed	2,716	182.49	Year Frozen		27,010	19,995		2,399	Penalty	0		Uncapped Value	0	0	0		0	Exemption	0	0.00	TIF Project ID	0	29,710	22,635		2,716	Total Taxable	2,716	182.00																																																																			
Source	REAL	Fair Cash	Capped	Asmnt Level	Assessed	Levy Rate	67.190	Current Tax																																																																																																																	
Remove Cap		2,700	2,640	12%	317	Assessed	2,716	182.49																																																																																																																	
Year Frozen		27,010	19,995		2,399	Penalty	0																																																																																																																		
Uncapped Value	0	0	0		0	Exemption	0	0.00																																																																																																																	
TIF Project ID	0	29,710	22,635		2,716	Total Taxable	2,716	182.00																																																																																																																	
Assessment History <table border="1"> <thead> <tr> <th>Tax Year</th> <th>Statement Number</th> <th>Billed Owner</th> <th>Tax Area</th> <th>Total Value</th> <th>Exemptions</th> <th>Taxable Value</th> <th>Billed Tax</th> </tr> </thead> <tbody> <tr><td>2025</td><td>2025-300006128</td><td>KAY, COY, &</td><td>202</td><td>29,710</td><td>0</td><td>2,587</td><td>174.00</td></tr> <tr><td>2024</td><td>2024-300006128</td><td>KAY, COY, &</td><td>202</td><td>31,820</td><td>0</td><td>2,464</td><td>164.00</td></tr> <tr><td>2023</td><td>2023-300006128</td><td>KAY, COY, &</td><td>202</td><td>29,029</td><td>0</td><td>2,346</td><td>158.00</td></tr> <tr><td>2022</td><td>2022-300006128</td><td>KAY, COY, &</td><td>202</td><td>20,962</td><td>0</td><td>2,235</td><td>151.00</td></tr> <tr><td>2021</td><td>2021-300006128</td><td>KAY, COY, &</td><td>202</td><td>21,802</td><td>0</td><td>2,129</td><td>147.00</td></tr> <tr><td>2020</td><td>2020-300006128</td><td>KAY, COY, &</td><td>202</td><td>21,802</td><td>0</td><td>2,027</td><td>137.00</td></tr> <tr><td>2019</td><td>2019-0006128</td><td>KAY, COY, &</td><td>202</td><td>21,802</td><td></td><td>1,931</td><td>115.00</td></tr> <tr><td>2018</td><td>2018-0006128</td><td>KAY, COY, &</td><td>202</td><td>23,646</td><td></td><td>1,839</td><td>110.00</td></tr> <tr><td>2017</td><td>2017-0006128</td><td>KAY, COY, &</td><td>202</td><td>22,719</td><td></td><td>1,752</td><td>105.00</td></tr> <tr><td>2016</td><td>2016-0006128</td><td>KAY, COY, &</td><td>202</td><td>22,719</td><td></td><td>1,668</td><td>100.00</td></tr> <tr><td>2015</td><td>2015-0006128</td><td>KAY, COY, &</td><td>202</td><td>16,957</td><td></td><td>1,589</td><td>95.00</td></tr> <tr><td>2014</td><td>2014-0006128</td><td>KAY, COY, &</td><td>202</td><td>18,056</td><td></td><td>1,514</td><td>90.00</td></tr> <tr><td>2013</td><td>2013-0006128</td><td>KAY, COY, &</td><td>202</td><td>27,692</td><td></td><td>1,442</td><td>86.00</td></tr> </tbody> </table>										Tax Year	Statement Number	Billed Owner	Tax Area	Total Value	Exemptions	Taxable Value	Billed Tax	2025	2025-300006128	KAY, COY, &	202	29,710	0	2,587	174.00	2024	2024-300006128	KAY, COY, &	202	31,820	0	2,464	164.00	2023	2023-300006128	KAY, COY, &	202	29,029	0	2,346	158.00	2022	2022-300006128	KAY, COY, &	202	20,962	0	2,235	151.00	2021	2021-300006128	KAY, COY, &	202	21,802	0	2,129	147.00	2020	2020-300006128	KAY, COY, &	202	21,802	0	2,027	137.00	2019	2019-0006128	KAY, COY, &	202	21,802		1,931	115.00	2018	2018-0006128	KAY, COY, &	202	23,646		1,839	110.00	2017	2017-0006128	KAY, COY, &	202	22,719		1,752	105.00	2016	2016-0006128	KAY, COY, &	202	22,719		1,668	100.00	2015	2015-0006128	KAY, COY, &	202	16,957		1,589	95.00	2014	2014-0006128	KAY, COY, &	202	18,056		1,514	90.00	2013	2013-0006128	KAY, COY, &	202	27,692		1,442	86.00
Tax Year	Statement Number	Billed Owner	Tax Area	Total Value	Exemptions	Taxable Value	Billed Tax																																																																																																																		
2025	2025-300006128	KAY, COY, &	202	29,710	0	2,587	174.00																																																																																																																		
2024	2024-300006128	KAY, COY, &	202	31,820	0	2,464	164.00																																																																																																																		
2023	2023-300006128	KAY, COY, &	202	29,029	0	2,346	158.00																																																																																																																		
2022	2022-300006128	KAY, COY, &	202	20,962	0	2,235	151.00																																																																																																																		
2021	2021-300006128	KAY, COY, &	202	21,802	0	2,129	147.00																																																																																																																		
2020	2020-300006128	KAY, COY, &	202	21,802	0	2,027	137.00																																																																																																																		
2019	2019-0006128	KAY, COY, &	202	21,802		1,931	115.00																																																																																																																		
2018	2018-0006128	KAY, COY, &	202	23,646		1,839	110.00																																																																																																																		
2017	2017-0006128	KAY, COY, &	202	22,719		1,752	105.00																																																																																																																		
2016	2016-0006128	KAY, COY, &	202	22,719		1,668	100.00																																																																																																																		
2015	2015-0006128	KAY, COY, &	202	16,957		1,589	95.00																																																																																																																		
2014	2014-0006128	KAY, COY, &	202	18,056		1,514	90.00																																																																																																																		
2013	2013-0006128	KAY, COY, &	202	27,692		1,442	86.00																																																																																																																		



Harper

Assessment Property Record Card for Tax Year 2026

Data provided by SHAYLYN WEDER County Assessor

Date 02/06/2026
 Time 07:17:36
 Page 2

Lot Data	Square-Foot - LAVERNE ORIGMULTI	Primary Image
Lot Size	75 x 90	 <p>2001-00-060-001-0-001-00 04/23/25</p>
Lot Count		
Units Buildable	2700	
Non-Ag Acres		
Topography		
Street Access		
Utilities		
Amenities		
Method	Square-Foot	
Base Lot Value	6,750.00 x .40 = 2,700	
Factor Value		
Adjustments		
Lot Value	2,700	

Residential Data	
Type	1 Single Family Residence
Condition	3.6 - Average
Quality	3 - Average
Architecture	TRAD TRADITIONAL
Style	100% One Story
Exterior Wall	100% Frame, Stucco
Base/Total Area	813 / 813
Style	100% One Story
HVAC	1 Wall Air Conditioners (Count)
Roof Cover	1 Composition Shingle
Area on Slab	0
Fixture/RghIn	5 /
Bed/F/H Bath	2 / 1.0 /
Basement Area	
Garage Type	280 Detached Garage - Unfinished
Remodel	
Year/Eff Age	1930 / 85

FRONT OF HOUSE 4/23/2025

GRM Approach

GRM Code	
Gross Rent	
Indicated Value	

Multiple Regression

MRA Code	
Adjusted R	
Indicated Value	

Direct Comparables

Selection Model	DEFAULT	DEFAULT SELECTION MODEL
Adjustment Model	DEFAULT	DEFAULT ADJUSTMENTS TABLE
Comparables		
Indicated Value		

Value Reconciliation

Selected Approach	Cost Approach		
Improvements	27,272		
Lot Value	2,700		
Indicated Value	29,972	36.87	Per SqFt
Agland Value			
Site Improvements			
Total Value	29,972	36.87	Total Value Per SqFt

Cost Approach		Manual :	
Base Cost	101.15	Total Misc Impr	+ 640
Roofing Adj	+ 4.71	Garage Cost	+ 11,814
Subfloor Adj	+ 0.00	Total RCN	= 104,892
Heat/Cool Adj	+ 0.00	Depreciation (74%)	- 77,620
Plumbing Adj	+ 7.84	Lump Sums	+ 0
Basement Adj	+ 0.00	RCNLD	= 27,272
Adj Base Cost	= 113.70	Lot Value	+ 2,700
Total Area	x 813	Indicated Value	= 29,972
Adjusted Cost	= 92,438	Value Per SqFt	36.87

Miscellaneous Improvements

Code	Description	Sketch ID	Size	Year	Units	Unit Cost	Depr	Value
PRCH	Slab Porch - Covered	5375	7x4		28	22.87		640



Harper

Assessment Property Record Card for Tax Year 2026

Data provided by SHAYLYN WEDER County Assessor

Date 02/06/2026
Time 07:17:36
Page 3

Sketch Image

300006128

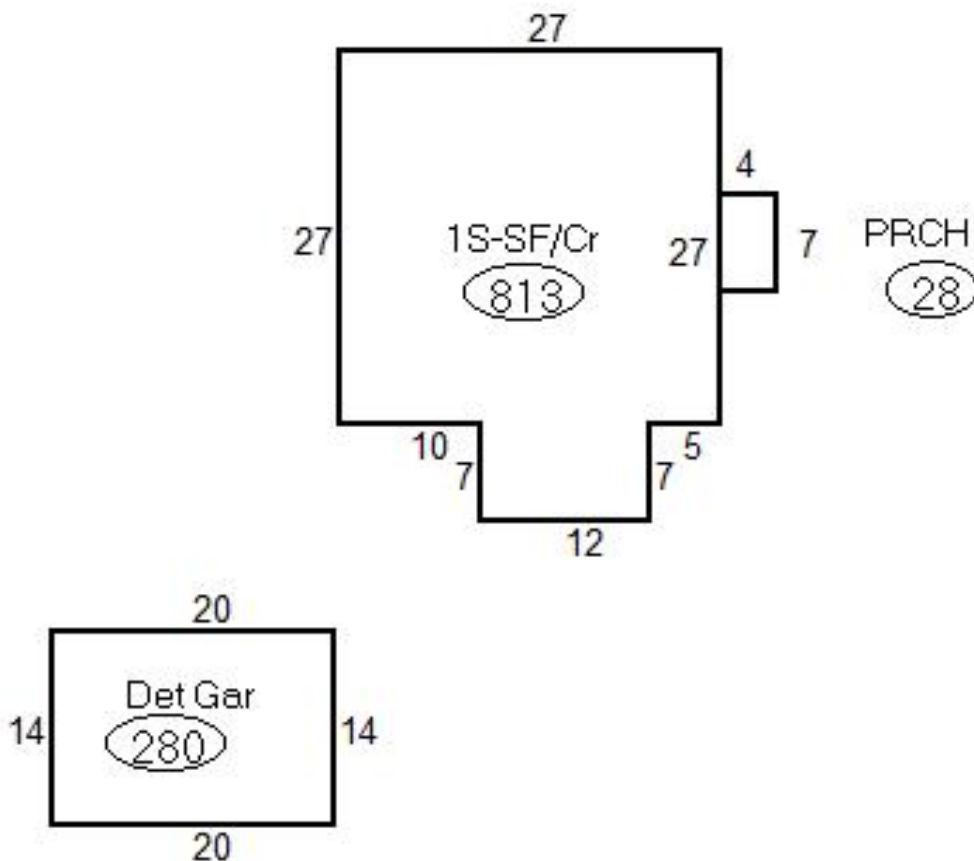

Sketch Vector Information

Sequence	Code	Type	Built Over	Scale	Section Label	Base Area	Multiplier	Total Area
1	R	1	Crawl	20	1S-SF/Cr	813	1.000	813
2	M	PRCH		20	PRCH	28	1.000	28
3	G	2		20	Det Gar	280	1.000	280
Total Building Area						813		813