



Harper

Assessment Property Record Card for Tax Year 2026

Data provided by SHAYLYN WEDER County Assessor

Date 02/06/2026
Time 07:21:17
Page 1

Assessment Data					Primary Image																																																																																																																			
Account 300006369 Parcel ID 2040-00-015-004-0-001-00 Cadastral ID 2040-015-004-00-0-001-00 Property Type REAL - Real Property Property Class UR VI Area 1 Tax Area 202 - 1T-LAVERNE-C Name ID 15361 BRINSON, CLIFFORD D. & BOBBIE L. BRINSON 522 S COUNTY LINE RD LAVERNE OK 73848-0000 Parcel Location Situs 00506 S COUNTY LINE RD Subdivision CORDES ADDN Lot/Block 0004 / 0015 Parcel Size 2 - Lots Sec/Twn/Rng / / / Neighborhood 200100 - LAVERNE ORIG\MULTI School District 1-LAVERN - 1-LAVERNE					 <p>2040-00-015-004-0-001-00 03/10/23</p> <p>2040-00-015-004-0-001-00_001.JPG 3/13/2023</p>																																																																																																																			
Legal Description Lat/Long: 36.71719042 -99.89046696 CORDES ADD BLOCK 15 LOTS 4-5 BOOK 613 PAGE 639																																																																																																																								
Exemptions <table border="1"> <thead> <tr> <th>Code</th> <th>Type</th> <th>Active</th> <th>Maximum</th> <th>Exemption</th> </tr> </thead> <tbody> <tr> <td></td> <td></td> <td></td> <td></td> <td></td> </tr> </tbody> </table>					Code	Type	Active	Maximum	Exemption						Building Permits <table border="1"> <thead> <tr> <th>Number</th> <th>Description</th> <th>Opened</th> <th>Closed</th> <th>Amount</th> </tr> </thead> <tbody> <tr> <td></td> <td></td> <td></td> <td></td> <td></td> </tr> </tbody> </table>					Number	Description	Opened	Closed	Amount																																																																																																
Code	Type	Active	Maximum	Exemption																																																																																																																				
Number	Description	Opened	Closed	Amount																																																																																																																				
Parcel Valuation <table border="1"> <thead> <tr> <th>Source</th> <th>REAL</th> <th>Fair Cash</th> <th>Capped</th> <th>Asmnt Level</th> <th>Assessed</th> <th>Levy Rate</th> <th>67.190</th> <th>Current Tax</th> </tr> </thead> <tbody> <tr> <td>Remove Cap</td> <td></td> <td>Land Value 2,800</td> <td>2,800</td> <td>12%</td> <td>336</td> <td>Assessed</td> <td>2,501</td> <td>168.04</td> </tr> <tr> <td>Year Frozen</td> <td></td> <td>Improvements 18,836</td> <td>18,043</td> <td></td> <td>2,165</td> <td>Penalty</td> <td>0</td> <td></td> </tr> <tr> <td>Uncapped Value</td> <td>0</td> <td>Mobile Home 0</td> <td>0</td> <td></td> <td>0</td> <td>Exemption</td> <td>0</td> <td>0.00</td> </tr> <tr> <td>TIF Project ID</td> <td>0</td> <td>Total Value 21,636</td> <td>20,843</td> <td></td> <td>2,501</td> <td>Total Taxable</td> <td>2,501</td> <td>168.00</td> </tr> </tbody> </table>					Source	REAL	Fair Cash	Capped	Asmnt Level	Assessed	Levy Rate	67.190	Current Tax	Remove Cap		Land Value 2,800	2,800	12%	336	Assessed	2,501	168.04	Year Frozen		Improvements 18,836	18,043		2,165	Penalty	0		Uncapped Value	0	Mobile Home 0	0		0	Exemption	0	0.00	TIF Project ID	0	Total Value 21,636	20,843		2,501	Total Taxable	2,501	168.00	Sale History <table border="1"> <thead> <tr> <th>Bk/Pg</th> <th>Grantor</th> <th>Date</th> <th>Price</th> <th>Code</th> </tr> </thead> <tbody> <tr> <td>661/431</td> <td>BAILEY, AMIEE J.</td> <td>08/20/2010</td> <td>20,000</td> <td>21</td> </tr> <tr> <td>613/639</td> <td>OLMSTEAD, GEORGE W.</td> <td>06/02/2006</td> <td>10,500</td> <td>MV</td> </tr> <tr> <td>557/696</td> <td>FOUTCH, DON ETAL</td> <td>07/10/2000</td> <td>15,000</td> <td>MU</td> </tr> <tr> <td>537/610</td> <td>NIELSEN, JONATHAN J. ETUX</td> <td>07/29/1998</td> <td>3,000</td> <td>Q</td> </tr> </tbody> </table>					Bk/Pg	Grantor	Date	Price	Code	661/431	BAILEY, AMIEE J.	08/20/2010	20,000	21	613/639	OLMSTEAD, GEORGE W.	06/02/2006	10,500	MV	557/696	FOUTCH, DON ETAL	07/10/2000	15,000	MU	537/610	NIELSEN, JONATHAN J. ETUX	07/29/1998	3,000	Q																																									
Source	REAL	Fair Cash	Capped	Asmnt Level	Assessed	Levy Rate	67.190	Current Tax																																																																																																																
Remove Cap		Land Value 2,800	2,800	12%	336	Assessed	2,501	168.04																																																																																																																
Year Frozen		Improvements 18,836	18,043		2,165	Penalty	0																																																																																																																	
Uncapped Value	0	Mobile Home 0	0		0	Exemption	0	0.00																																																																																																																
TIF Project ID	0	Total Value 21,636	20,843		2,501	Total Taxable	2,501	168.00																																																																																																																
Bk/Pg	Grantor	Date	Price	Code																																																																																																																				
661/431	BAILEY, AMIEE J.	08/20/2010	20,000	21																																																																																																																				
613/639	OLMSTEAD, GEORGE W.	06/02/2006	10,500	MV																																																																																																																				
557/696	FOUTCH, DON ETAL	07/10/2000	15,000	MU																																																																																																																				
537/610	NIELSEN, JONATHAN J. ETUX	07/29/1998	3,000	Q																																																																																																																				
Assessment History <table border="1"> <thead> <tr> <th>Tax Year</th> <th>Statement Number</th> <th>Billed Owner</th> <th>Tax Area</th> <th>Total Value</th> <th>Exemptions</th> <th>Taxable Value</th> <th>Billed Tax</th> </tr> </thead> <tbody> <tr><td>2025</td><td>2025-300006369</td><td>BRINSON, CLIFFORD D. &</td><td>202</td><td>21,636</td><td>0</td><td>2,382</td><td>160.00</td></tr> <tr><td>2024</td><td>2024-300006369</td><td>BRINSON, CLIFFORD D. &</td><td>202</td><td>23,112</td><td>0</td><td>2,269</td><td>151.00</td></tr> <tr><td>2023</td><td>2023-300006369</td><td>BRINSON, CLIFFORD D. &</td><td>202</td><td>18,006</td><td>0</td><td>2,161</td><td>145.00</td></tr> <tr><td>2022</td><td>2022-300006369</td><td>BRINSON, CLIFFORD D. &</td><td>202</td><td>18,006</td><td>0</td><td>2,154</td><td>146.00</td></tr> <tr><td>2021</td><td>2021-300006369</td><td>BRINSON, CLIFFORD D. &</td><td>202</td><td>18,006</td><td>0</td><td>2,052</td><td>142.00</td></tr> <tr><td>2020</td><td>2020-300006369</td><td>BRINSON, CLIFFORD D. &</td><td>202</td><td>18,006</td><td>0</td><td>1,954</td><td>132.00</td></tr> <tr><td>2019</td><td>2019-0006369</td><td>BRINSON, CLIFFORD D. &</td><td>202</td><td>18,007</td><td></td><td>1,861</td><td>111.00</td></tr> <tr><td>2018</td><td>2018-0006369</td><td>BRINSON, CLIFFORD D. &</td><td>202</td><td>19,554</td><td></td><td>1,772</td><td>106.00</td></tr> <tr><td>2017</td><td>2017-0006369</td><td>BRINSON, CLIFFORD D. &</td><td>202</td><td>18,818</td><td></td><td>1,689</td><td>101.00</td></tr> <tr><td>2016</td><td>2016-0006369</td><td>BRINSON, CLIFFORD D. &</td><td>202</td><td>18,818</td><td></td><td>1,608</td><td>96.00</td></tr> <tr><td>2015</td><td>2015-0006369</td><td>BRINSON, CLIFFORD D. &</td><td>202</td><td>18,590</td><td></td><td>1,530</td><td>91.00</td></tr> <tr><td>2014</td><td>2014-0006369</td><td>BRINSON, CLIFFORD D. &</td><td>202</td><td>19,807</td><td></td><td>1,458</td><td>87.00</td></tr> <tr><td>2013</td><td>2013-0006369</td><td>BRINSON, CLIFFORD D. &</td><td>202</td><td>24,475</td><td></td><td>1,389</td><td>83.00</td></tr> </tbody> </table>									Tax Year	Statement Number	Billed Owner	Tax Area	Total Value	Exemptions	Taxable Value	Billed Tax	2025	2025-300006369	BRINSON, CLIFFORD D. &	202	21,636	0	2,382	160.00	2024	2024-300006369	BRINSON, CLIFFORD D. &	202	23,112	0	2,269	151.00	2023	2023-300006369	BRINSON, CLIFFORD D. &	202	18,006	0	2,161	145.00	2022	2022-300006369	BRINSON, CLIFFORD D. &	202	18,006	0	2,154	146.00	2021	2021-300006369	BRINSON, CLIFFORD D. &	202	18,006	0	2,052	142.00	2020	2020-300006369	BRINSON, CLIFFORD D. &	202	18,006	0	1,954	132.00	2019	2019-0006369	BRINSON, CLIFFORD D. &	202	18,007		1,861	111.00	2018	2018-0006369	BRINSON, CLIFFORD D. &	202	19,554		1,772	106.00	2017	2017-0006369	BRINSON, CLIFFORD D. &	202	18,818		1,689	101.00	2016	2016-0006369	BRINSON, CLIFFORD D. &	202	18,818		1,608	96.00	2015	2015-0006369	BRINSON, CLIFFORD D. &	202	18,590		1,530	91.00	2014	2014-0006369	BRINSON, CLIFFORD D. &	202	19,807		1,458	87.00	2013	2013-0006369	BRINSON, CLIFFORD D. &	202	24,475		1,389	83.00
Tax Year	Statement Number	Billed Owner	Tax Area	Total Value	Exemptions	Taxable Value	Billed Tax																																																																																																																	
2025	2025-300006369	BRINSON, CLIFFORD D. &	202	21,636	0	2,382	160.00																																																																																																																	
2024	2024-300006369	BRINSON, CLIFFORD D. &	202	23,112	0	2,269	151.00																																																																																																																	
2023	2023-300006369	BRINSON, CLIFFORD D. &	202	18,006	0	2,161	145.00																																																																																																																	
2022	2022-300006369	BRINSON, CLIFFORD D. &	202	18,006	0	2,154	146.00																																																																																																																	
2021	2021-300006369	BRINSON, CLIFFORD D. &	202	18,006	0	2,052	142.00																																																																																																																	
2020	2020-300006369	BRINSON, CLIFFORD D. &	202	18,006	0	1,954	132.00																																																																																																																	
2019	2019-0006369	BRINSON, CLIFFORD D. &	202	18,007		1,861	111.00																																																																																																																	
2018	2018-0006369	BRINSON, CLIFFORD D. &	202	19,554		1,772	106.00																																																																																																																	
2017	2017-0006369	BRINSON, CLIFFORD D. &	202	18,818		1,689	101.00																																																																																																																	
2016	2016-0006369	BRINSON, CLIFFORD D. &	202	18,818		1,608	96.00																																																																																																																	
2015	2015-0006369	BRINSON, CLIFFORD D. &	202	18,590		1,530	91.00																																																																																																																	
2014	2014-0006369	BRINSON, CLIFFORD D. &	202	19,807		1,458	87.00																																																																																																																	
2013	2013-0006369	BRINSON, CLIFFORD D. &	202	24,475		1,389	83.00																																																																																																																	



Harper

Assessment Property Record Card for Tax Year 2026

Data provided by SHAYLYN WEDER County Assessor

Date 02/06/2026
 Time 07:21:17
 Page 2

Lot Data	Square-Foot - LAVERNE ORIGMULTI	Primary Image
Lot Size	50 x 140	<p>2040-00-015-004-0-001-00 03/10/23</p> <p>2040-00-015-004-0-001-00_001.JPG 3/13/2023</p>
Lot Count		
Units Buildable	2800	
Non-Ag Acres		
Topography		
Street Access		
Utilities		
Amenities		
Method	Square-Foot	
Base Lot Value	7,000.00 x .40 = 2,800	
Factor Value		
Adjustments		
Lot Value	2,800	

Residential Data	
Type	1 Single Family Residence
Condition	2 - Fair
Quality	2.5 - Fair
Architecture	TRAD TRADITIONAL
Style	100% One Story
Exterior Wall	100% Frame, Stucco
Base/Total Area	712 / 712
Style	100% One Story
HVAC	100% Floor Furnace
Roof Cover	1 Composition Shingle
Area on Slab	0
Fixture/RghIn	5 /
Bed/F/H Bath	2 / 1.0 /
Basement Area	
Garage Type	432 Detached Garage - Unfinished
Remodel	
Year/Eff Age	1940 / 103

Cost Approach		Manual :	
Base Cost	98.72	Total Misc Impr	+ 913
Roofing Adj	+ 4.47	Garage Cost	+ 12,907
Subfloor Adj	+ 1.17	Total RCN	= 95,024
Heat/Cool Adj	+ 1.56	Depreciation (80%)	- 76,019
Plumbing Adj	+ 8.13	Lump Sums	+ 0
Basement Adj	+ 0.00	RCNLD	= 19,005
Adj Base Cost	= 114.05	Lot Value	+ 2,800
Total Area	x 712	Indicated Value	= 21,805
Adjusted Cost	= 81,204	Value Per SqFt	30.63

GRM Approach
GRM Code
Gross Rent
Indicated Value

Multiple Regression
MRA Code
Adusted R
Indicated Value

Direct Comparables		
Selection Model	DEFAULT	DEFAULT SELECTION MODEL
Adjustment Model	DEFAULT	DEFAULT ADJUSTMENTS TABLE
Comparables		
Indicated Value		

Value Reconciliation		
Selected Approach	Cost Approach	
Improvements	19,005	
Lot Value	2,800	
Indicated Value	21,805	30.63 Per SqFt
Agland Value		
Site Improvements		
Total Value	21,805	30.63 Total Value Per SqFt

Miscellaneous Improvements								
Code	Description	Sketch ID	Size	Year	Units	Unit Cost	Depr	Value
PRCH	Slab Porch - Covered	6103	4x4		16	20.63		330
RSPC	Raised Slab Porch - Covered	6104	4x4		16	36.46		583



Harper

Assessment Property Record Card for Tax Year 2026

Data provided by SHAYLYN WEDER County Assessor

Date 02/06/2026
 Time 07:21:17
 Page 3

Sketch Image

300006369

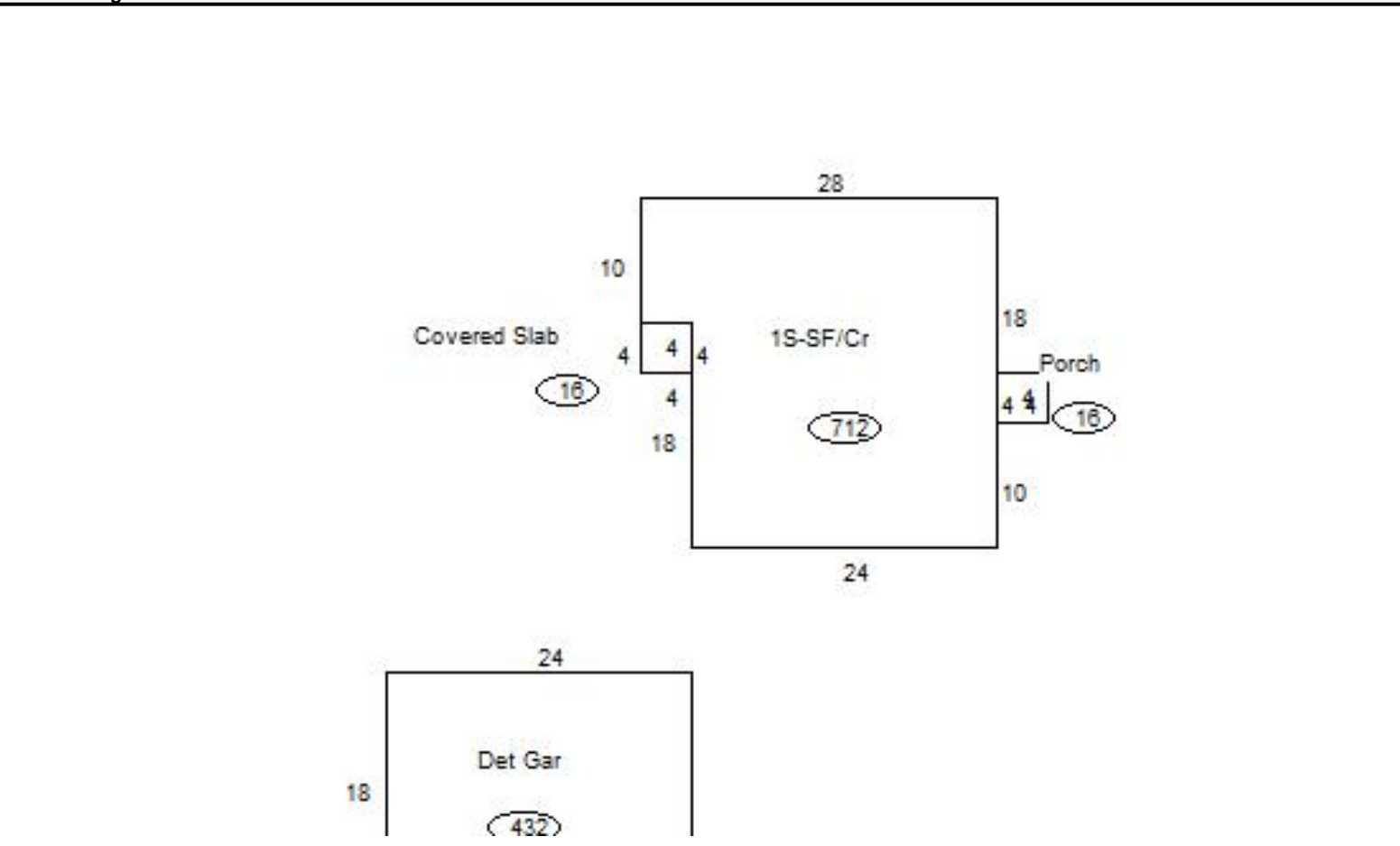

Sketch Vector Information

Sequence	Code	Type	Built Over	Scale	Section Label	Base Area	Multiplier	Total Area
1	R	1	Crawl	20	1S-SF/Cr	712	1.000	712
2	M	PRCH		20	Covered Slab	16	1.000	16
3	M	RSPC		20	Porch	16	1.000	16
4	G	2		20	Det Gar	432	1.000	432
Total Building Area						712		712