



# Harper

## Assessment Property Record Card for Tax Year 2026

Data provided by SHAYLYN WEDER County Assessor

Date 02/06/2026  
 Time 07:23:51  
 Page 1

Assessment Data					Primary Image									
Account	300006544				 <p>FRONT OF HOUSE 4/30/2025</p>									
Parcel ID	2143-00-001-014-0-001-00													
Cadastral ID	2143-001-014-00-0-001-00													
Property Type	REAL - Real Property													
Property Class	UR	VI Area	3											
Tax Area	202 - 1T-LAVERNE-C													
Name ID	15482													
MONTGOMERY,JOYCE HUGHES FAMILY TRUST														
PO BOX 434 LAVERNE OK 73848-0000														
Parcel Location														
Situs	01106 W JANE JAYROE													
Subdivision	SHUMAN'S 3RD ADDN													
Lot/Block	0014 / 0001	Parcel Size	1 - Lots											
Sec/Twn/Rng	/ / /													
Neighborhood	200200 - SHUMANS\PARKWEID													
School District	1-LAVERN - 1-LAVERNE													
Legal Description Lat/Long: 36.70802555 -99.89909218														
SHUMAN'S 3RD ADD BLOCK 1 LOT 14 BOOK 643 PAGE 348														
Building Permits														
<table border="1"> <thead> <tr> <th>Number</th> <th>Description</th> <th>Opened</th> <th>Closed</th> <th>Amount</th> </tr> </thead> <tbody> <tr> <td> </td> <td> </td> <td> </td> <td> </td> <td> </td> </tr> </tbody> </table>					Number	Description	Opened	Closed	Amount					
Number	Description	Opened	Closed	Amount										
Exemptions														
Code	Type	Active	Maximum	Exemption										
H	Homestead	Yes	1,000	1,000										
Sale History														
Bk/Pg	Grantor	Date	Price	Code										
Parcel Valuation														
Source	REAL	Fair Cash	Capped	Asmnt Level	Assessed	Levy Rate	67.190	Current Tax						
Remove Cap		Land Value	4,613	4,053	12%	486	Assessed	8,566 575.55						
Year Frozen		Improvements	82,675	67,326		8,080	Penalty	0						
Uncapped Value	0	Mobile Home	0	0		0	Exemption	1,000 -68.00						
TIF Project ID	0	Total Value	87,288	71,379		8,566	Total Taxable	7,566 508.00						
Assessment History														
Tax Year	Statement Number	Billed Owner	Tax Area	Total Value	Exemptions	Taxable Value	Billed Tax							
2025	2025-300006544	MONTGOMERY,JOYCE HUGHES FAMILY TRUST	202	87,288	1000	7,315	491.00							
2024	2024-300006544	MONTGOMERY,JOYCE HUGHES FAMILY TRUST	202	96,767	1000	7,073	470.00							
2023	2023-300006544	MONTGOMERY,JOYCE HUGHES FAMILY TRUST	202	90,275	1000	6,839	459.00							
2022	2022-300006544	MONTGOMERY,JOYCE HUGHES TRUST	202	78,052	1000	6,610	447.00							
2021	2021-300006544	MONTGOMERY,JOYCE HUGHES TRUST	202	77,653	1000	6,388	441.00							
2020	2020-300006544	MONTGOMERY,JOYCE HUGHES TRUST	202	77,653	1000	6,174	418.00							
2019	2019-0006544	MONTGOMERY,JOYCE HUGHES TRUST	202	79,625		5,964	356.00							
2018	2018-0006544	MONTGOMERY,JOYCE HUGHES,TRUST	202	81,598		5,762	344.00							
2017	2017-0006544	MONTGOMERY,JOYCE HUGHES,TRUST	202	77,653		5,565	332.00							
2016	2016-0006544	MONTGOMERY,JOYCE HUGHES,TRUST	202	79,522		5,374	321.00							
2015	2015-0006544	MONTGOMERY,JOYCE HUGHES,TRUST	202	81,626		6,070	362.00							
2014	2014-0006544	MONTGOMERY,JOYCE HUGHES,TRUST	202	83,549		5,781	345.00							
2013	2013-0006544	MONTGOMERY,JOYCE HUGHES,TRUST	202	99,494		5,506	329.00							



# Harper

## Assessment Property Record Card for Tax Year 2026

Data provided by SHAYLYN WEDER County Assessor

Date 02/06/2026  
 Time 07:23:51  
 Page 2

Lot Data		Square-Foot - SHUMANS\PARK\WEID	
Lot Size	77.43	x	132.4
Lot Count			
Units Buildable	4613		
Non-Ag Acres			
Topography			
Street Access			
Utilities			
Amenities			
Method	Square-Foot		
Base Lot Value	10,251.73	x	.45 = 4,613
Factor Value			
Adjustments			
Lot Value	4,613		



Residential Data	
Type	1 Single Family Residence
Condition	3 - Average
Quality	3 - Average
Architecture	TRAD TRADITIONAL
Style	100% One Story
Exterior Wall	100% Veneer, Masonry
Base/Total Area	1,484 / 1,484
Style	100% One Story
HVAC	100% Warmed & Cooled Air
Roof Cover	1 Composition Shingle
Area on Slab	0
Fixture/RghIn	5 /
Bed/F/H Bath	2 / 1.0 /
Basement Area	
Garage Type	352 Attached Garage - Unfinished
Remodel	UPDATE -
Year/Eff Age	1967 / 52

GRM Approach	
GRM Code	
Gross Rent	
Indicated Value	

Multiple Regression	
MRA Code	
Adusted R	
Indicated Value	

Direct Comparables	
Selection Model	DEFAULT DEFAULT SELECTION MODEL
Adjustment Model	DEFAULT DEFAULT ADJUSTMENTS TABLE
Comparables	
Indicated Value	

Cost Approach		Manual :	
Base Cost	90.86	Total Misc Impr	+ 6,103
Roofing Adj	+ 3.97	Garage Cost	+ 10,535
Subfloor Adj	+ 0.00	Total RCN	= 179,730
Heat/Cool Adj	+ 10.77	Depreciation ( 57%)	- 102,446
Plumbing Adj	+ 4.30	Lump Sums	+ 0
Basement Adj	+ 0.00	RCNLD	= 77,284
Adj Base Cost	= 109.90	Lot Value	+ 4,613
Total Area	x 1,484	Indicated Value	= 81,897
Adjusted Cost	= 163,092	Value Per SqFt	55.19

Value Reconciliation			
Selected Approach	Cost Approach		
Improvements	77,284		
Lot Value	4,613		
Indicated Value	81,897	55.19	Per SqFt
Agland Value			
Site Improvements	604		
Total Value	82,501	55.59	Total Value Per SqFt

Miscellaneous Improvements								
Code	Description	Sketch ID	Size	Year	Units	Unit Cost	Depr	Value
PATC	Patio - Covered	6610	18x11		198	15.77		3,122
PRCH	Porch	6612	22x6		132	22.58		2,981



Harper

Assessment Property Record Card for Tax Year 2026

Data provided by SHAYLYN WEDER County Assessor

Date 02/06/2026  
Time 07:23:51  
Page 3

Sketch Image

300006544

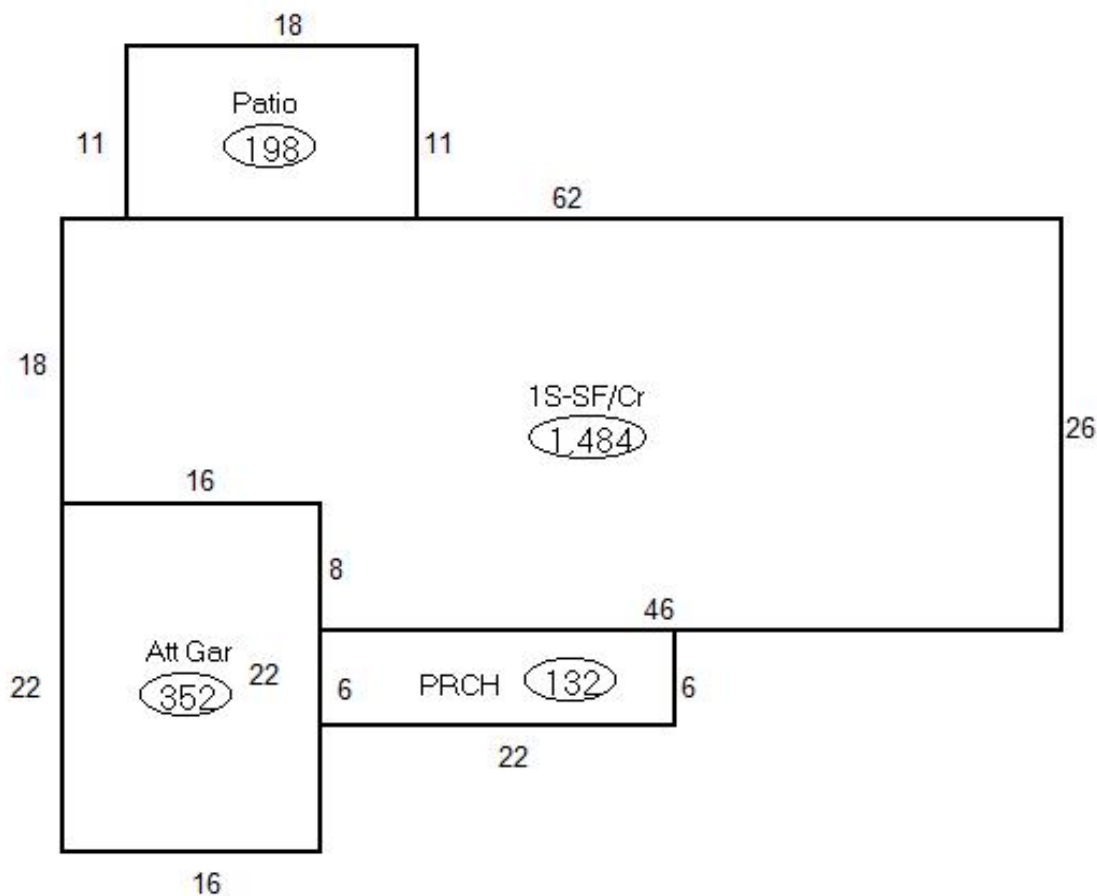

Sketch Vector Information

Sequence	Code	Type	Built Over	Scale	Section Label	Base Area	Multiplier	Total Area
1	R	1	Crawl	13	1S-SF/Cr	1,484	1.000	1,484
2	M	PATC		13	Patio	198	1.000	198
3	G	1		13	Att Gar	352	1.000	352
4	M	PRCH		13	PRCH	132	1.000	132
<b>Total Building Area</b>						<b>1,484</b>		<b>1,484</b>



# Harper



## Assessment Property Record Card for Tax Year 2026

Data provided by SHAYLYN WEDER County Assessor

Date 02/06/2026  
 Time 07:23:51  
 Page 4

300006544

### Outbuildings/Site Improvements

Building Image	Code	Description	Dimensions	Floor	Roofing	Total Units	
 <p>2143-00-001-014-0-001-00 #6544 5-19-2021</p>	PACN	SIDEWALK	28x8x0	Concrete		224	
	Qual	3	Cond 3	Year 2010	Eff Age 16		
		<b>Valuation Summary</b>	<b>Modifier Total</b>	<b>RCN</b>	<b>Depr (80% Phys/ % Func)</b>	<b>RCNLD</b>	
		Base Cost (5.29 x 224)	1,185		1,185	948	237
	PACN	Paving - Concrete DRIVEWAY	22x20x0	Concrete		440	
	Qual	3	Cond 3	Year 2000	Eff Age 26		
		<b>Valuation Summary</b>	<b>Modifier Total</b>	<b>RCN</b>	<b>Depr (80% Phys/ % Func)</b>	<b>RCNLD</b>	
		Base Cost (4.17 x 440)	1,835		1,835	1,468	367