



Rogers

Assessment Property Record Card for Tax Year 2026

Data provided by LISA DELOZIER County Assessor

Date 04/18/2026
Time 07:28:51
Page 1

Assessment Data					Primary Image														
Account 660000941 Parcel ID 000000-00-0-00807-012-0014 Cadastral ID 01-22-15-04320 Property Type REAL - Real Property Property Class RRP VI Area 4 Tax Area 11 - SEQUOYAH/NW FIRE Name ID 326276 WATT, LELAND & MELISSA WATT 9624 E OAK ST CLAREMORE OK 74017-0000 Parcel Location Situs 09624 E OAK ST Subdivision TACORA HILLS Lot/Block 0014 / 0012 Parcel Size 1 - Lots Sec/Twn/Rng 1 / 22 / 15 / 5 Neighborhood 1085 - R-V04-NW SEQUOYAH School District S006 - SEQUOYAH SCHOOLS					 <p style="text-align: right; color: orange;">03/24/2022 12:49</p> <p>\\tsclient\T\TOMMY DUNLAP\New folder (32)\IMG_0030.JPG 3/25/2022</p>														
Legal Description Lat/Long: 36.41678073 -95.65721933																			
LOT 14 BLOCK 12 TACORA HILLS					Building Permits <table border="1"> <thead> <tr> <th>Number</th> <th>Description</th> <th>Opened</th> <th>Closed</th> <th>Amount</th> </tr> </thead> <tbody> <tr> <td> </td> <td> </td> <td> </td> <td> </td> <td> </td> </tr> </tbody> </table>					Number	Description	Opened	Closed	Amount					
Number	Description	Opened	Closed	Amount															
Exemptions					Sale History														
Code	Type	Active	Maximum	Exemption	Bk/Pg	Grantor	Date	Price	Code										
H	Homestead	Yes	1,000	1,000	/	BRADSHAW, BRADLEY J &	11/19/2018	120,500	WG										
					2229/695	FEDERAL NATIONAL MORTGAGE ASS	02/28/2012	35,000	11										
					2191/751	GILLILAND, MICHAEL S &	08/26/2011	0	10										
					1138/218	HARTZELL, DONALD J &	10/19/1998	79,000	No										
					914/400	MARCUM, IRIS ANN GREEN	05/04/1993	2,000	Yes										
Parcel Valuation																			
Source	REAL		Fair Cash	Capped	Asmnt Level	Assessed	Levy Rate	102.332	Current Tax										
Remove Cap	2019		Land Value 26,671	14,858	11%	1,634	Assessed	14,673	1,501.51										
Year Frozen	0		Improvements 129,496	118,539		13,039	Penalty	0											
Uncapped Value	0		Mobile Home 0	0		0	Exemption	1,000	-89.00										
TIF Project ID	0		Total Value 156,167	133,397		14,673	Total Taxable	13,673	1,413.00										
Assessment History																			
Tax Year	Statement Number	Billed Owner			Tax Area	Total Value	Exemptions	Taxable Value	Billed Tax										
2025	2025-660000941	WATT, LELAND &			11	153,662	1000	13,247	1,370.00										
2024	2024-660000941	WATT, LELAND &			11	162,685	1000	12,832	1,332.00										
2023	2023-660000941	WATT, LELAND &			11	122,078	1000	12,429	1,316.00										
2022	2022-660000941	WATT, LELAND &			11	125,607	1000	12,302	1,311.00										
2021	2021-660000941	WATT, LELAND &			11	117,400	1000	11,915	1,227.00										
2020	2020-660000941	WATT, LELAND &			11	117,953	1000	11,780	1,252.00										
2019	2019-660000941	WATT, LELAND &			11	112,793	1000	11,408	1,197.00										
2018	2018-660000941	BRADSHAW, BRADLEY J &			11	66,465	0	6,367	667.00										
2017	2017-660000941	BRADSHAW, BRADLEY J &			11	65,978	0	6,064	620.00										
2016	2016-660000941	BRADSHAW, BRADLEY J &			11	64,427	0	5,775	594.00										
2015	2015-660000941	BRADSHAW, BRADLEY J &			11	50,000	0	5,500	572.00										
2014	2014-660000941	BRADSHAW, BRADLEY J &			11	50,000	0	5,500	572.00										
2013	2013-660000941	BRADSHAW, BRADLEY J &			11	50,000	0	5,500	562.00										



Rogers

Assessment Property Record Card for Tax Year 2026

Data provided by LISA DELOZIER County Assessor

Date 04/18/2026
Time 07:28:52
Page 2

Lot Data	Square-Foot - NBHD 1085 #1	Primary Image
Lot Size		
Lot Count		
Units Buildable	1	
Non-Ag Acres	0.1944	
Topography		
Street Access		
Utilities		
Amenities	LAND QUALITY 0	
	0	
Method	Square-Foot	
Base Lot Value	8,467.00 x 3.15 = 26,671	
Factor Value		
Adjustments	1.0000	
Lot Value	26,671	

Residential Data	
Type	1 Single Family Residence
Condition	3 - Average
Quality	2 - Fair
Architecture	
Style	100% One Story
Exterior Wall	100% Frame, Siding, Wood
Base/Total Area	1,540 / 1,540
Style	100% One Story
HVAC	100% Warmed & Cooled Air
Roof Cover	1 Composition Shingle
Area on Slab	0
Fixture/RghIn	11 /
Bed/F/H Bath	2 / 2.0 /
Basement Area	
Garage Type	484 Attached Garage - Unfinished
Remodel	
Year/Eff Age	1994 / 24



\\tsclient\T\TOMMY DUNLAP\New folder (32)\IMG_0030.JPG 3/25/2022

GRM Approach	
GRM Code	
Gross Rent	0.00
Indicated Value	

Multiple Regression			
MRA Code	1	Test	
Adusted R	0.8445		
Indicated Value	160,058	103.93	Per SqFt

Direct Comparables	
Selection Model	A Adam Test
Adjustment Model	1 2022 Residential
Comparables	
Indicated Value	

Cost Approach				Manual : 01/2025			
Base Cost	89.98	Total Misc Impr	+	11,002			
Roofing Adj	+ 4.03	Garage Cost	+	11,369			
Subfloor Adj	+ 2.31	Total RCN	=	199,225			
Heat/Cool Adj	+ 10.30	Depreciation (35%)	-	69,729			
Plumbing Adj	+ 8.22	Lump Sums	+	0			
Basement Adj	+ 0.00	RCNLD	=	129,496			
Adj Base Cost	= 114.84	Lot Value	+	26,671			
Total Area	x 1,540	Indicated Value	=	156,167			
Adjusted Cost	= 176,854	Value Per SqFt		101.41			

Value Reconciliation			
Selected Approach	Cost Approach		
Improvements	129,496		
Lot Value	26,671		
Indicated Value	156,167	101.41	Per SqFt
Agland Value			
Site Improvements			
Total Value	156,167	101.41	Total Value Per SqFt

Miscellaneous Improvements								
Code	Description	Sketch ID	Size	Year	Units	Unit Cost	Depr	Value
FPR1	FIREPLACE - RESIDENTIAL 1 STORY	0		1	1	4,576.55		4,577
CPDT	CARPORT - DETACHED	2691	20x18		360	10.13		3,647
PATO	SLAB PORCH - OPEN	2692	254		254	8.60		2,184
PATO	SLAB PORCH - OPEN	2693	58		58	10.24		594



Rogers

Assessment Property Record Card for Tax Year 2026

Data provided by LISA DELOZIER County Assessor

Date 04/18/2026
 Time 07:28:52
 Page 3

Sketch Image

660000941

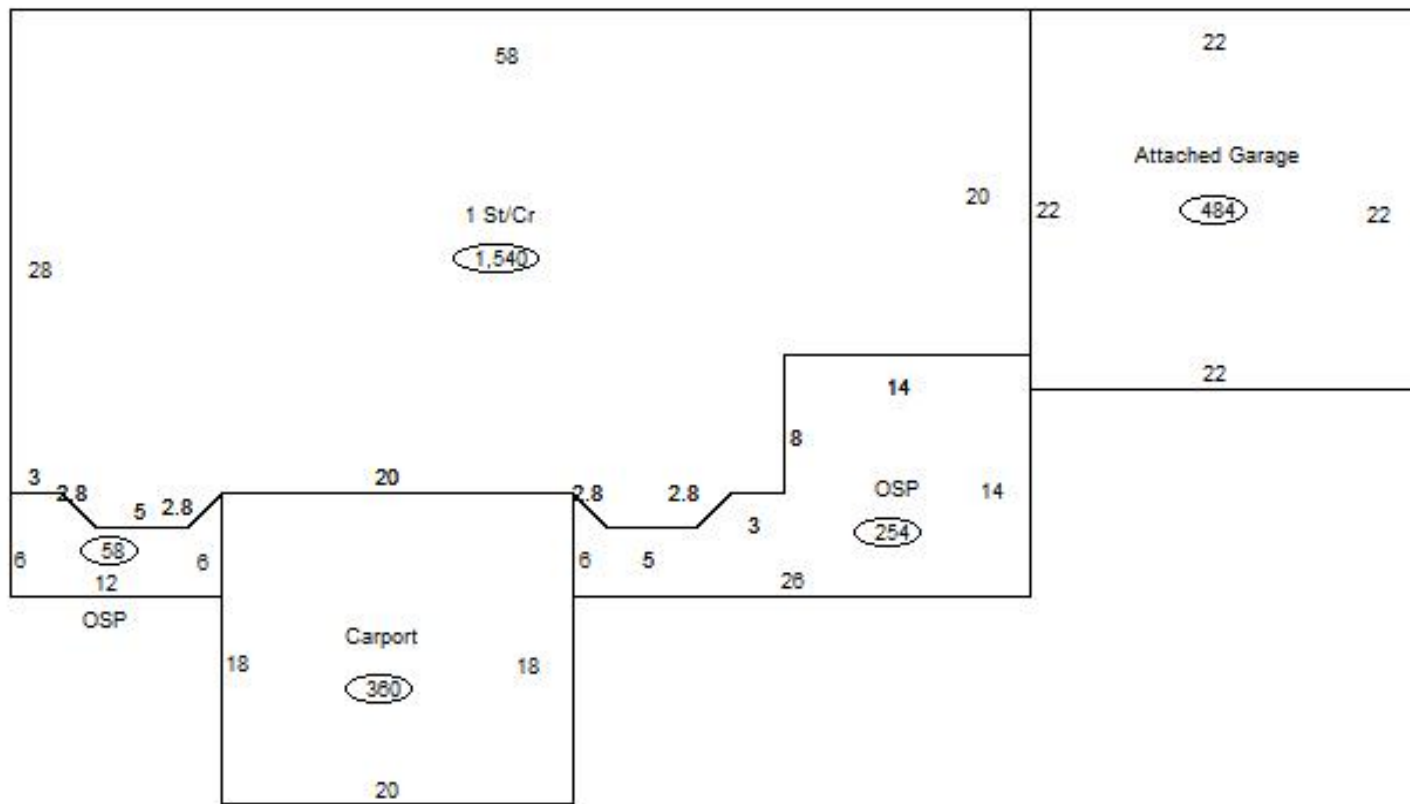

Sketch Vector Information

Sequence	Code	Type	Built Over	Scale	Section Label	Base Area	Multiplier	Total Area
1	R	1	Crawl	13	1 St/Cr	1,540	1.000	1,540
2	G	1		13	Attached Garage	484	1.000	484
3	M	CPDT		13	Carport	360	1.000	360
4	M	PATO		13	Open Slab	254	1.000	254
5	M	PATO		13	Open Slab	58	1.000	58
Total Building Area						1,540		1,540