



Rogers

Assessment Property Record Card for Tax Year 2026

Data provided by LISA DELOZIER County Assessor

Date 04/17/2026
Time 03:56:27
Page 1

| Assessment Data | | | | | Primary Image | | | | | | | | | | | | | | | | | | | | | | | | | | | | | | | | | | | | | | | | | | | | | | | | | | | | | | | | | | | | | | | | | | | | | | | | | | | | | | | | | | | | | | | | | | | | | | | | | | | | | | | | | | | | | | | | | | | | |
|--|-------------------------|---------------------------|----------|-------------|---|---------------|------------|-------------|-------------|----------|------------------|--------------|-------------|-------------|---|-------------------|------------|------|----------------|---------------------------|-------------|----------|-------------|--------|----------------------|---------|----------------|---------------------------|---------|---------|------|----------------|----------|---------------|----------------|---------------------------|---|-----------|-------|--------|----------------|------|---------------------|---------------------------|---|---------|---------------|--------|----------|--|----------------|---------------------------|---|---------|-------|---------|----------|-------|----------------|---------------------------|-------------------------|------------|---------|--------|----------|-----------------------|----------------|---------------------------|-----|----------|-----------------|------------|----------|------|----------------|---------------------------|------------|---------|------|--------|----------|------|----------------|---------------------------|---|---------|------|--------|----------|------|----------------|---------------------------|---|---------|------|--------|----------|------|----------------|---------------------------|---|---------|------|--------|----------|------|----------------|---------------------------|---|---------|------|--------|----------|------|----------------|---------------------------|---|---------|------|--------|----------|
| Account 660002142 Parcel ID 000000-00-0-00081-001-0012 Cadastral ID 03-20-15-05720 Property Type REAL - Real Property Property Class RRP VI Area 3 Tax Area 4 - VERDIGRIS/VERD FIRE Name ID 277239 RIEDESEL, DAVID & REBECCA 7704 E BRIT DR CLAREMORE OK 74019-0000 Parcel Location Situs 07704 BRIT DR Subdivision BRIT PARK Lot/Block 0012 / 0001 Parcel Size 1 - Lots Sec/Twn/Rng 3 / 20 / 15 / 5 Neighborhood 1046 - R-V03-SW VERDIGRIS School District S008 - VERDIGRIS SCHOOLS | | | | |  <p>\\tsclient\T\LOGAN\LOGAN RESIDENTIAL VI\2021-10-19\IMG_00: 10/26/2021</p> | | | | | | | | | | | | | | | | | | | | | | | | | | | | | | | | | | | | | | | | | | | | | | | | | | | | | | | | | | | | | | | | | | | | | | | | | | | | | | | | | | | | | | | | | | | | | | | | | | | | | | | | | | | | | | | | | | | | |
| Legal Description Lot/Long: 36.24084769 -95.69151303 LOT 12 BLOCK 1 BRIT PARK | | | | | | | | | | | | | | | | | | | | | | | | | | | | | | | | | | | | | | | | | | | | | | | | | | | | | | | | | | | | | | | | | | | | | | | | | | | | | | | | | | | | | | | | | | | | | | | | | | | | | | | | | | | | | | | | | | | | | | | | | |
| Exemptions <table border="1"> <thead> <tr> <th>Code</th> <th>Type</th> <th>Active</th> <th>Maximum</th> <th>Exemption</th> </tr> </thead> <tbody> <tr> <td>H</td> <td>Homestead</td> <td>Yes</td> <td>1,000</td> <td>1,000</td> </tr> </tbody> </table> | | | | | Code | Type | Active | Maximum | Exemption | H | Homestead | Yes | 1,000 | 1,000 | Building Permits <table border="1"> <thead> <tr> <th>Number</th> <th>Description</th> <th>Opened</th> <th>Closed</th> <th>Amount</th> </tr> </thead> <tbody> <tr> <td></td> <td></td> <td></td> <td></td> <td></td> </tr> </tbody> </table> | | | | | Number | Description | Opened | Closed | Amount | | | | | | | | | | | | | | | | | | | | | | | | | | | | | | | | | | | | | | | | | | | | | | | | | | | | | | | | | | | | | | | | | | | | | | | | | | | | | | | | | | | | | | | | | | | | | | | | | |
| Code | Type | Active | Maximum | Exemption | | | | | | | | | | | | | | | | | | | | | | | | | | | | | | | | | | | | | | | | | | | | | | | | | | | | | | | | | | | | | | | | | | | | | | | | | | | | | | | | | | | | | | | | | | | | | | | | | | | | | | | | | | | | | | | | | | | | | |
| H | Homestead | Yes | 1,000 | 1,000 | | | | | | | | | | | | | | | | | | | | | | | | | | | | | | | | | | | | | | | | | | | | | | | | | | | | | | | | | | | | | | | | | | | | | | | | | | | | | | | | | | | | | | | | | | | | | | | | | | | | | | | | | | | | | | | | | | | | | |
| Number | Description | Opened | Closed | Amount | | | | | | | | | | | | | | | | | | | | | | | | | | | | | | | | | | | | | | | | | | | | | | | | | | | | | | | | | | | | | | | | | | | | | | | | | | | | | | | | | | | | | | | | | | | | | | | | | | | | | | | | | | | | | | | | | | | | | |
| | | | | | | | | | | | | | | | | | | | | | | | | | | | | | | | | | | | | | | | | | | | | | | | | | | | | | | | | | | | | | | | | | | | | | | | | | | | | | | | | | | | | | | | | | | | | | | | | | | | | | | | | | | | | | | | | | | | | | | | | | |
| Parcel Valuation <table border="1"> <thead> <tr> <th>Source</th> <th>REAL</th> <th>Fair Cash</th> <th>Capped</th> <th>Asmnt Level</th> <th>Assessed</th> <th>Levy Rate</th> <th>104.132</th> <th>Current Tax</th> </tr> </thead> <tbody> <tr> <td>Remove Cap</td> <td>2002</td> <td>Land Value 34,325</td> <td>33,283</td> <td>11%</td> <td>3,661</td> <td>Assessed</td> <td>25,629</td> <td>2,668.79</td> </tr> <tr> <td>Year Frozen</td> <td>0</td> <td>Improvements 202,806</td> <td>199,705</td> <td></td> <td>21,968</td> <td>Penalty</td> <td>0</td> <td></td> </tr> <tr> <td>Uncapped Value</td> <td>0</td> <td>Mobile Home 0</td> <td>0</td> <td></td> <td>0</td> <td>Exemption</td> <td>1,000</td> <td>-87.00</td> </tr> <tr> <td>TIF Project ID</td> <td>0</td> <td>Total Value 237,131</td> <td>232,988</td> <td></td> <td>25,629</td> <td>Total Taxable</td> <td>24,629</td> <td>2,582.00</td> </tr> </tbody> </table> | | | | | Source | REAL | Fair Cash | Capped | Asmnt Level | Assessed | Levy Rate | 104.132 | Current Tax | Remove Cap | 2002 | Land Value 34,325 | 33,283 | 11% | 3,661 | Assessed | 25,629 | 2,668.79 | Year Frozen | 0 | Improvements 202,806 | 199,705 | | 21,968 | Penalty | 0 | | Uncapped Value | 0 | Mobile Home 0 | 0 | | 0 | Exemption | 1,000 | -87.00 | TIF Project ID | 0 | Total Value 237,131 | 232,988 | | 25,629 | Total Taxable | 24,629 | 2,582.00 | Sale History <table border="1"> <thead> <tr> <th>Bk/Pg</th> <th>Grantor</th> <th>Date</th> <th>Price</th> <th>Code</th> </tr> </thead> <tbody> <tr> <td>1302/44</td> <td>DORSEY, TERRY - TRUSTEE</td> <td>07/06/2001</td> <td>143,000</td> <td>5</td> </tr> <tr> <td>1075/344</td> <td>SHORT, AL D & DEBRA L</td> <td>07/02/1997</td> <td>103,000</td> <td>Yes</td> </tr> <tr> <td>1036/201</td> <td>DORSEY, DAVID L</td> <td>08/20/1996</td> <td>103,000</td> <td>Yes</td> </tr> <tr> <td>991/540</td> <td>STEIDLEY TRUST</td> <td>06/02/1995</td> <td>14,500</td> <td>Yes</td> </tr> </tbody> </table> | | | | | Bk/Pg | Grantor | Date | Price | Code | 1302/44 | DORSEY, TERRY - TRUSTEE | 07/06/2001 | 143,000 | 5 | 1075/344 | SHORT, AL D & DEBRA L | 07/02/1997 | 103,000 | Yes | 1036/201 | DORSEY, DAVID L | 08/20/1996 | 103,000 | Yes | 991/540 | STEIDLEY TRUST | 06/02/1995 | 14,500 | Yes | | | | | | | | | | | | | | | | | | | | | | | | | | | | | | | | | | | | | | | | | | |
| Source | REAL | Fair Cash | Capped | Asmnt Level | Assessed | Levy Rate | 104.132 | Current Tax | | | | | | | | | | | | | | | | | | | | | | | | | | | | | | | | | | | | | | | | | | | | | | | | | | | | | | | | | | | | | | | | | | | | | | | | | | | | | | | | | | | | | | | | | | | | | | | | | | | | | | | | | | | | | | | | | |
| Remove Cap | 2002 | Land Value 34,325 | 33,283 | 11% | 3,661 | Assessed | 25,629 | 2,668.79 | | | | | | | | | | | | | | | | | | | | | | | | | | | | | | | | | | | | | | | | | | | | | | | | | | | | | | | | | | | | | | | | | | | | | | | | | | | | | | | | | | | | | | | | | | | | | | | | | | | | | | | | | | | | | | | | | |
| Year Frozen | 0 | Improvements 202,806 | 199,705 | | 21,968 | Penalty | 0 | | | | | | | | | | | | | | | | | | | | | | | | | | | | | | | | | | | | | | | | | | | | | | | | | | | | | | | | | | | | | | | | | | | | | | | | | | | | | | | | | | | | | | | | | | | | | | | | | | | | | | | | | | | | | | | | | | |
| Uncapped Value | 0 | Mobile Home 0 | 0 | | 0 | Exemption | 1,000 | -87.00 | | | | | | | | | | | | | | | | | | | | | | | | | | | | | | | | | | | | | | | | | | | | | | | | | | | | | | | | | | | | | | | | | | | | | | | | | | | | | | | | | | | | | | | | | | | | | | | | | | | | | | | | | | | | | | | | | |
| TIF Project ID | 0 | Total Value 237,131 | 232,988 | | 25,629 | Total Taxable | 24,629 | 2,582.00 | | | | | | | | | | | | | | | | | | | | | | | | | | | | | | | | | | | | | | | | | | | | | | | | | | | | | | | | | | | | | | | | | | | | | | | | | | | | | | | | | | | | | | | | | | | | | | | | | | | | | | | | | | | | | | | | | |
| Bk/Pg | Grantor | Date | Price | Code | | | | | | | | | | | | | | | | | | | | | | | | | | | | | | | | | | | | | | | | | | | | | | | | | | | | | | | | | | | | | | | | | | | | | | | | | | | | | | | | | | | | | | | | | | | | | | | | | | | | | | | | | | | | | | | | | | | | | |
| 1302/44 | DORSEY, TERRY - TRUSTEE | 07/06/2001 | 143,000 | 5 | | | | | | | | | | | | | | | | | | | | | | | | | | | | | | | | | | | | | | | | | | | | | | | | | | | | | | | | | | | | | | | | | | | | | | | | | | | | | | | | | | | | | | | | | | | | | | | | | | | | | | | | | | | | | | | | | | | | | |
| 1075/344 | SHORT, AL D & DEBRA L | 07/02/1997 | 103,000 | Yes | | | | | | | | | | | | | | | | | | | | | | | | | | | | | | | | | | | | | | | | | | | | | | | | | | | | | | | | | | | | | | | | | | | | | | | | | | | | | | | | | | | | | | | | | | | | | | | | | | | | | | | | | | | | | | | | | | | | | |
| 1036/201 | DORSEY, DAVID L | 08/20/1996 | 103,000 | Yes | | | | | | | | | | | | | | | | | | | | | | | | | | | | | | | | | | | | | | | | | | | | | | | | | | | | | | | | | | | | | | | | | | | | | | | | | | | | | | | | | | | | | | | | | | | | | | | | | | | | | | | | | | | | | | | | | | | | | |
| 991/540 | STEIDLEY TRUST | 06/02/1995 | 14,500 | Yes | | | | | | | | | | | | | | | | | | | | | | | | | | | | | | | | | | | | | | | | | | | | | | | | | | | | | | | | | | | | | | | | | | | | | | | | | | | | | | | | | | | | | | | | | | | | | | | | | | | | | | | | | | | | | | | | | | | | | |
| Assessment History <table border="1"> <thead> <tr> <th>Tax Year</th> <th>Statement Number</th> <th>Billed Owner</th> <th>Tax Area</th> <th>Total Value</th> <th>Exemptions</th> <th>Taxable Value</th> <th>Billed Tax</th> </tr> </thead> <tbody> <tr><td>2025</td><td>2025-660002142</td><td>RIEDESEL, DAVID & REBECCA</td><td>4</td><td>228,213</td><td>1000</td><td>23,883</td><td>2,504.00</td></tr> <tr><td>2024</td><td>2024-660002142</td><td>RIEDESEL, DAVID & REBECCA</td><td>4</td><td>241,697</td><td>1000</td><td>23,158</td><td>2,230.00</td></tr> <tr><td>2023</td><td>2023-660002142</td><td>RIEDESEL, DAVID & REBECCA</td><td>4</td><td>213,218</td><td>1000</td><td>22,454</td><td>2,130.00</td></tr> <tr><td>2022</td><td>2022-660002142</td><td>RIEDESEL, DAVID & REBECCA</td><td>4</td><td>217,764</td><td>1000</td><td>22,566</td><td>2,179.00</td></tr> <tr><td>2021</td><td>2021-660002142</td><td>RIEDESEL, DAVID & REBECCA</td><td>4</td><td>208,503</td><td>1000</td><td>21,880</td><td>2,058.00</td></tr> <tr><td>2020</td><td>2020-660002142</td><td>RIEDESEL, DAVID & REBECCA</td><td>4</td><td>204,964</td><td>1000</td><td>21,214</td><td>2,000.00</td></tr> <tr><td>2019</td><td>2019-660002142</td><td>RIEDESEL, DAVID & REBECCA</td><td>4</td><td>196,060</td><td>1000</td><td>20,567</td><td>1,969.00</td></tr> <tr><td>2018</td><td>2018-660002142</td><td>RIEDESEL, DAVID & REBECCA</td><td>4</td><td>202,121</td><td>1000</td><td>21,233</td><td>2,034.00</td></tr> <tr><td>2017</td><td>2017-660002142</td><td>RIEDESEL, DAVID & REBECCA</td><td>4</td><td>199,601</td><td>1000</td><td>20,956</td><td>2,012.00</td></tr> <tr><td>2016</td><td>2016-660002142</td><td>RIEDESEL, DAVID & REBECCA</td><td>4</td><td>194,966</td><td>1000</td><td>20,446</td><td>1,970.00</td></tr> <tr><td>2015</td><td>2015-660002142</td><td>RIEDESEL, DAVID & REBECCA</td><td>4</td><td>190,374</td><td>1000</td><td>19,941</td><td>1,936.00</td></tr> <tr><td>2014</td><td>2014-660002142</td><td>RIEDESEL, DAVID & REBECCA</td><td>4</td><td>192,256</td><td>1000</td><td>19,508</td><td>1,793.00</td></tr> <tr><td>2013</td><td>2013-660002142</td><td>RIEDESEL, DAVID & REBECCA</td><td>4</td><td>183,799</td><td>1000</td><td>18,910</td><td>1,801.00</td></tr> </tbody> </table> | | | | | | | | | | Tax Year | Statement Number | Billed Owner | Tax Area | Total Value | Exemptions | Taxable Value | Billed Tax | 2025 | 2025-660002142 | RIEDESEL, DAVID & REBECCA | 4 | 228,213 | 1000 | 23,883 | 2,504.00 | 2024 | 2024-660002142 | RIEDESEL, DAVID & REBECCA | 4 | 241,697 | 1000 | 23,158 | 2,230.00 | 2023 | 2023-660002142 | RIEDESEL, DAVID & REBECCA | 4 | 213,218 | 1000 | 22,454 | 2,130.00 | 2022 | 2022-660002142 | RIEDESEL, DAVID & REBECCA | 4 | 217,764 | 1000 | 22,566 | 2,179.00 | 2021 | 2021-660002142 | RIEDESEL, DAVID & REBECCA | 4 | 208,503 | 1000 | 21,880 | 2,058.00 | 2020 | 2020-660002142 | RIEDESEL, DAVID & REBECCA | 4 | 204,964 | 1000 | 21,214 | 2,000.00 | 2019 | 2019-660002142 | RIEDESEL, DAVID & REBECCA | 4 | 196,060 | 1000 | 20,567 | 1,969.00 | 2018 | 2018-660002142 | RIEDESEL, DAVID & REBECCA | 4 | 202,121 | 1000 | 21,233 | 2,034.00 | 2017 | 2017-660002142 | RIEDESEL, DAVID & REBECCA | 4 | 199,601 | 1000 | 20,956 | 2,012.00 | 2016 | 2016-660002142 | RIEDESEL, DAVID & REBECCA | 4 | 194,966 | 1000 | 20,446 | 1,970.00 | 2015 | 2015-660002142 | RIEDESEL, DAVID & REBECCA | 4 | 190,374 | 1000 | 19,941 | 1,936.00 | 2014 | 2014-660002142 | RIEDESEL, DAVID & REBECCA | 4 | 192,256 | 1000 | 19,508 | 1,793.00 | 2013 | 2013-660002142 | RIEDESEL, DAVID & REBECCA | 4 | 183,799 | 1000 | 18,910 | 1,801.00 |
| Tax Year | Statement Number | Billed Owner | Tax Area | Total Value | Exemptions | Taxable Value | Billed Tax | | | | | | | | | | | | | | | | | | | | | | | | | | | | | | | | | | | | | | | | | | | | | | | | | | | | | | | | | | | | | | | | | | | | | | | | | | | | | | | | | | | | | | | | | | | | | | | | | | | | | | | | | | | | | | | | | | |
| 2025 | 2025-660002142 | RIEDESEL, DAVID & REBECCA | 4 | 228,213 | 1000 | 23,883 | 2,504.00 | | | | | | | | | | | | | | | | | | | | | | | | | | | | | | | | | | | | | | | | | | | | | | | | | | | | | | | | | | | | | | | | | | | | | | | | | | | | | | | | | | | | | | | | | | | | | | | | | | | | | | | | | | | | | | | | | | |
| 2024 | 2024-660002142 | RIEDESEL, DAVID & REBECCA | 4 | 241,697 | 1000 | 23,158 | 2,230.00 | | | | | | | | | | | | | | | | | | | | | | | | | | | | | | | | | | | | | | | | | | | | | | | | | | | | | | | | | | | | | | | | | | | | | | | | | | | | | | | | | | | | | | | | | | | | | | | | | | | | | | | | | | | | | | | | | | |
| 2023 | 2023-660002142 | RIEDESEL, DAVID & REBECCA | 4 | 213,218 | 1000 | 22,454 | 2,130.00 | | | | | | | | | | | | | | | | | | | | | | | | | | | | | | | | | | | | | | | | | | | | | | | | | | | | | | | | | | | | | | | | | | | | | | | | | | | | | | | | | | | | | | | | | | | | | | | | | | | | | | | | | | | | | | | | | | |
| 2022 | 2022-660002142 | RIEDESEL, DAVID & REBECCA | 4 | 217,764 | 1000 | 22,566 | 2,179.00 | | | | | | | | | | | | | | | | | | | | | | | | | | | | | | | | | | | | | | | | | | | | | | | | | | | | | | | | | | | | | | | | | | | | | | | | | | | | | | | | | | | | | | | | | | | | | | | | | | | | | | | | | | | | | | | | | | |
| 2021 | 2021-660002142 | RIEDESEL, DAVID & REBECCA | 4 | 208,503 | 1000 | 21,880 | 2,058.00 | | | | | | | | | | | | | | | | | | | | | | | | | | | | | | | | | | | | | | | | | | | | | | | | | | | | | | | | | | | | | | | | | | | | | | | | | | | | | | | | | | | | | | | | | | | | | | | | | | | | | | | | | | | | | | | | | | |
| 2020 | 2020-660002142 | RIEDESEL, DAVID & REBECCA | 4 | 204,964 | 1000 | 21,214 | 2,000.00 | | | | | | | | | | | | | | | | | | | | | | | | | | | | | | | | | | | | | | | | | | | | | | | | | | | | | | | | | | | | | | | | | | | | | | | | | | | | | | | | | | | | | | | | | | | | | | | | | | | | | | | | | | | | | | | | | | |
| 2019 | 2019-660002142 | RIEDESEL, DAVID & REBECCA | 4 | 196,060 | 1000 | 20,567 | 1,969.00 | | | | | | | | | | | | | | | | | | | | | | | | | | | | | | | | | | | | | | | | | | | | | | | | | | | | | | | | | | | | | | | | | | | | | | | | | | | | | | | | | | | | | | | | | | | | | | | | | | | | | | | | | | | | | | | | | | |
| 2018 | 2018-660002142 | RIEDESEL, DAVID & REBECCA | 4 | 202,121 | 1000 | 21,233 | 2,034.00 | | | | | | | | | | | | | | | | | | | | | | | | | | | | | | | | | | | | | | | | | | | | | | | | | | | | | | | | | | | | | | | | | | | | | | | | | | | | | | | | | | | | | | | | | | | | | | | | | | | | | | | | | | | | | | | | | | |
| 2017 | 2017-660002142 | RIEDESEL, DAVID & REBECCA | 4 | 199,601 | 1000 | 20,956 | 2,012.00 | | | | | | | | | | | | | | | | | | | | | | | | | | | | | | | | | | | | | | | | | | | | | | | | | | | | | | | | | | | | | | | | | | | | | | | | | | | | | | | | | | | | | | | | | | | | | | | | | | | | | | | | | | | | | | | | | | |
| 2016 | 2016-660002142 | RIEDESEL, DAVID & REBECCA | 4 | 194,966 | 1000 | 20,446 | 1,970.00 | | | | | | | | | | | | | | | | | | | | | | | | | | | | | | | | | | | | | | | | | | | | | | | | | | | | | | | | | | | | | | | | | | | | | | | | | | | | | | | | | | | | | | | | | | | | | | | | | | | | | | | | | | | | | | | | | | |
| 2015 | 2015-660002142 | RIEDESEL, DAVID & REBECCA | 4 | 190,374 | 1000 | 19,941 | 1,936.00 | | | | | | | | | | | | | | | | | | | | | | | | | | | | | | | | | | | | | | | | | | | | | | | | | | | | | | | | | | | | | | | | | | | | | | | | | | | | | | | | | | | | | | | | | | | | | | | | | | | | | | | | | | | | | | | | | | |
| 2014 | 2014-660002142 | RIEDESEL, DAVID & REBECCA | 4 | 192,256 | 1000 | 19,508 | 1,793.00 | | | | | | | | | | | | | | | | | | | | | | | | | | | | | | | | | | | | | | | | | | | | | | | | | | | | | | | | | | | | | | | | | | | | | | | | | | | | | | | | | | | | | | | | | | | | | | | | | | | | | | | | | | | | | | | | | | |
| 2013 | 2013-660002142 | RIEDESEL, DAVID & REBECCA | 4 | 183,799 | 1000 | 18,910 | 1,801.00 | | | | | | | | | | | | | | | | | | | | | | | | | | | | | | | | | | | | | | | | | | | | | | | | | | | | | | | | | | | | | | | | | | | | | | | | | | | | | | | | | | | | | | | | | | | | | | | | | | | | | | | | | | | | | | | | | | |



Rogers

Assessment Property Record Card for Tax Year 2026

Data provided by LISA DELOZIER County Assessor

Date 04/17/2026
Time 03:56:27
Page 2

| Lot Data | | Square-Foot - NBHD 1046 #1 | | Primary Image | | | | |
|----------------------------|---|----------------------------|-----------|----------------------|--------------------|---|----------|--------|
| Lot Size | | | | | | \\tsclient\T\LOGAN\LOGAN RESIDENTIAL VI\2021-10-19\IMG_00: 10/26/2021 | | |
| Lot Count | | | | | | | | |
| Units Buildable | 1 | | | | | | | |
| Non-Ag Acres | 1.1085 | | | | | | | |
| Topography | | | | | | | | |
| Street Access | | | | | | | | |
| Utilities | | | | | | | | |
| Amenities | 0 | | | | | | | |
| | 0 | | | | | | | |
| Method | Square-Foot | | | | | | | |
| Base Lot Value | 48,288.00 x .71 = 34,325 | | | | | | | |
| Factor Value | | | | | | | | |
| Adjustments | 1.0000 | | | | | | | |
| Lot Value | 34,325 | | | | | | | |
| Residential Data | | | | | | | | |
| Type | 1 Single Family Residence | | | | | | | |
| Condition | 3 - Average | | | | | | | |
| Quality | 2.5 - Fair | | | | | | | |
| Architecture | TRAD TRADITIONAL | | | | | | | |
| Style | 100% One Story | | | | | | | |
| Exterior Wall | 30% Veneer, Masonry 70% Frame, Siding, Wood | | | | | | | |
| Base/Total Area | 1,925 / 1,925 | | | | | | | |
| Style | 100% One Story | | | | | | | |
| HVAC | 100% Warmed & Cooled Air | | | | | | | |
| Roof Cover | 1 Composition Shingle | | | | | | | |
| Area on Slab | 1,925 | | | | | | | |
| Fixture/RghIn | 11 / | | | | | | | |
| Bed/F/H Bath | 3 / 2.0 / | | | | | | | |
| Basement Area | | | | | | | | |
| Garage Type | 336 Attached Garage - Finished | | | | | | | |
| Remodel | | | | | | | | |
| Year/Eff Age | 1995 / 23 | | | | | | | |
| Cost Approach | | Manual : 01/2025 | | GRM Approach | | | | |
| Base Cost | 95.84 | Total Misc Impr | + 10,428 | GRM Code | | | | |
| Roofing Adj | + 4.30 | Garage Cost | + 12,949 | Gross Rent | 0.00 | | | |
| Subfloor Adj | + -1.12 | Total RCN | = 250,142 | Indicated Value | | | | |
| Heat/Cool Adj | + 11.47 | Depreciation (30%) | - 75,043 | Multiple Regression | | | | |
| Plumbing Adj | + 7.31 | Lump Sums | + 27,707 | MRA Code | 1 Test | | | |
| Basement Adj | + 0.00 | RCNLD | = 202,806 | Adusted R | 0.8445 | | | |
| Adj Base Cost | = 117.80 | Lot Value | + 34,325 | Indicated Value | 190,491 | 98.96 | Per SqFt | |
| Total Area | x 1,925 | Indicated Value | = 237,131 | Direct Comparables | | | | |
| Adjusted Cost | = 226,765 | Value Per SqFt | 123.18 | Selection Model | A Adam Test | | | |
| | | | | Adjustment Model | 1 2022 Residential | | | |
| | | | | Comparables | 2 | | | |
| | | | | Indicated Value | 258,490 | | Per SqFt | |
| Miscellaneous Improvements | | | | Value Reconciliation | | | | |
| Code | Description | Sketch ID | Size | Year | Units | Unit Cost | Depr | Value |
| FPR1 | FIREPLACE - RESIDENTIAL 1 STORY | 0 | | 1 | 1 | 5,095.98 | | 5,096 |
| PRCH | SLAB PORCH - COVERED | 5882 | | 36 | 36 | 24.16 | | 870 |
| PRCH | SLAB PORCH - COVERED | 5883 | | 189 | 189 | 23.61 | | 4,462 |
| GRDT | Garage - Detached | 178715 | 42x30 | | 1,260 | 21.99 | | 27,707 |



Rogers

Assessment Property Record Card for Tax Year 2026

Data provided by LISA DELOZIER County Assessor

Date 04/17/2026
 Time 03:56:27
 Page 3

Sketch Image

660002142

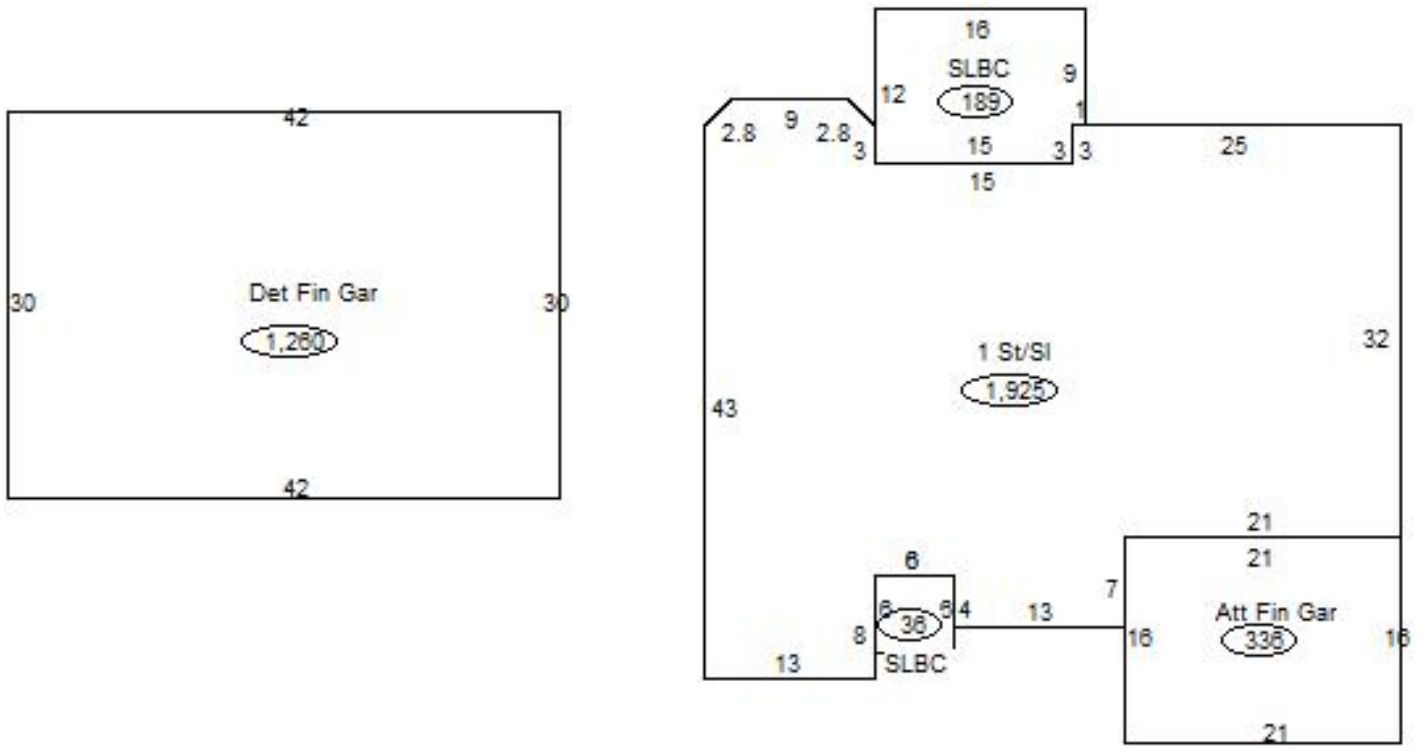

Sketch Vector Information

| Sequence | Code | Type | Built Over | Scale | Section Label | Base Area | Multiplier | Total Area |
|----------------------------|------|------|------------|-------|---------------|-----------|------------|------------|
| 1 | R | 1 | Slab | 20 | 1 St/Sl | 1,925 | 1.000 | 1,925 |
| 2 | G | 5 | | 20 | Att Fin Gar | 336 | 1.000 | 336 |
| 3 | M | PRCH | | 20 | SLBC | 36 | 1.000 | 36 |
| 4 | M | PRCH | | 20 | SLBC | 189 | 1.000 | 189 |
| 5 | G | 6 | | 20 | Det Fin Gar | 1,260 | 1.000 | 1,260 |
| Total Building Area | | | | | | 1,925 | | 1,925 |