



# Rogers

## Assessment Property Record Card for Tax Year 2026

Data provided by LISA DELOZIER County Assessor

Date 04/17/2026  
Time 03:23:59  
Page 1

| Assessment Data   |                        |               |          |             | Primary Image   |               |               |             |           |                            |                  |              |            |             |   |                 |            |          |                |               |             |         |              |        |          |               |                |               |    |          |                   |            |             |      |                |                        |            |           |    |        |                |      |                |               |         |         |        |               |          |          |                |               |    |         |   |        |          |      |                |               |    |         |   |        |          |      |                |               |    |         |   |        |          |      |                |               |    |         |   |        |          |      |                |               |    |         |   |        |          |      |                |               |    |         |   |        |          |      |                |               |    |         |   |        |          |      |                |               |    |         |   |        |          |      |                |               |    |         |   |        |          |
|---|------------------------|---------------|----------|-------------|---|---------------|---------------|-------------|-----------|----------------------------|------------------|--------------|------------|-------------|---|-----------------|------------|----------|----------------|---------------|-------------|---------|--------------|--------|----------|---------------|----------------|---------------|----|----------|-------------------|------------|-------------|------|----------------|------------------------|------------|-----------|----|--------|----------------|------|----------------|---------------|---------|---------|--------|---------------|----------|----------|----------------|---------------|----|---------|---|--------|----------|------|----------------|---------------|----|---------|---|--------|----------|------|----------------|---------------|----|---------|---|--------|----------|------|----------------|---------------|----|---------|---|--------|----------|------|----------------|---------------|----|---------|---|--------|----------|------|----------------|---------------|----|---------|---|--------|----------|------|----------------|---------------|----|---------|---|--------|----------|------|----------------|---------------|----|---------|---|--------|----------|------|----------------|---------------|----|---------|---|--------|----------|
| <b>Account</b> 660003067<br><b>Parcel ID</b> 000000-00-0-10070-002-0004<br><b>Cadastral ID</b> 04-21-16-00580<br><b>Property Type</b> REAL - Real Property<br><b>Property Class</b> URP VI Area 1<br><b>Tax Area</b> 17 - CLAREMORE OT<br><b>Name ID</b> 297818<br>MCGILL, NANCY<br><br>20822 S 4180 RD<br>CLAREMORE OK 74019-4466<br><br><b>Parcel Location</b><br><b>Situs</b> 01218 CHERRINGTON<br><b>Subdivision</b> CHERRY ACRES<br><b>Lot/Block</b> 0004 / 0002 <b>Parcel Size</b> 1 - Lots<br><b>Sec/Twn/Rng</b> 4 / 21 / 16 / 5<br><b>Neighborhood</b> 1162 - R-V01-SW CLAREMORE<br><b>School District</b> S001 - CLAREMORE SCHOOLS   |                        |               |          |             | <p>\\tsclient\T\TOMMY DUNLAP\New folder (165)\IMG_0060.JPG 4/5/2023</p>   |               |               |             |           |                            |                  |              |            |             |   |                 |            |          |                |               |             |         |              |        |          |               |                |               |    |          |                   |            |             |      |                |                        |            |           |    |        |                |      |                |               |         |         |        |               |          |          |                |               |    |         |   |        |          |      |                |               |    |         |   |        |          |      |                |               |    |         |   |        |          |      |                |               |    |         |   |        |          |      |                |               |    |         |   |        |          |      |                |               |    |         |   |        |          |      |                |               |    |         |   |        |          |      |                |               |    |         |   |        |          |      |                |               |    |         |   |        |          |
| <b>Legal Description</b> Lot/Long: 36.32284699 -95.60611290   |                        |               |          |             |   |               |               |             |           |                            |                  |              |            |             |   |                 |            |          |                |               |             |         |              |        |          |               |                |               |    |          |                   |            |             |      |                |                        |            |           |    |        |                |      |                |               |         |         |        |               |          |          |                |               |    |         |   |        |          |      |                |               |    |         |   |        |          |      |                |               |    |         |   |        |          |      |                |               |    |         |   |        |          |      |                |               |    |         |   |        |          |      |                |               |    |         |   |        |          |      |                |               |    |         |   |        |          |      |                |               |    |         |   |        |          |      |                |               |    |         |   |        |          |
| <b>Building Permits</b>   |                        |               |          |             | <table border="1"> <thead> <tr> <th>Number</th> <th>Description</th> <th>Opened</th> <th>Closed</th> <th>Amount</th> </tr> </thead> <tbody> <tr> <td>2537</td> <td>2 ROOM ADDITION</td> <td>06/2000</td> <td>09/2001</td> <td>15,000</td> </tr> </tbody> </table> |               |               |             |           | Number                     | Description      | Opened       | Closed     | Amount      | 2537  | 2 ROOM ADDITION | 06/2000    | 09/2001  | 15,000         |               |             |         |              |        |          |               |                |               |    |          |                   |            |             |      |                |                        |            |           |    |        |                |      |                |               |         |         |        |               |          |          |                |               |    |         |   |        |          |      |                |               |    |         |   |        |          |      |                |               |    |         |   |        |          |      |                |               |    |         |   |        |          |      |                |               |    |         |   |        |          |      |                |               |    |         |   |        |          |      |                |               |    |         |   |        |          |      |                |               |    |         |   |        |          |      |                |               |    |         |   |        |          |
| Number  | Description            | Opened        | Closed   | Amount      |   |               |               |             |           |                            |                  |              |            |             |   |                 |            |          |                |               |             |         |              |        |          |               |                |               |    |          |                   |            |             |      |                |                        |            |           |    |        |                |      |                |               |         |         |        |               |          |          |                |               |    |         |   |        |          |      |                |               |    |         |   |        |          |      |                |               |    |         |   |        |          |      |                |               |    |         |   |        |          |      |                |               |    |         |   |        |          |      |                |               |    |         |   |        |          |      |                |               |    |         |   |        |          |      |                |               |    |         |   |        |          |      |                |               |    |         |   |        |          |
| 2537  | 2 ROOM ADDITION        | 06/2000       | 09/2001  | 15,000      |   |               |               |             |           |                            |                  |              |            |             |   |                 |            |          |                |               |             |         |              |        |          |               |                |               |    |          |                   |            |             |      |                |                        |            |           |    |        |                |      |                |               |         |         |        |               |          |          |                |               |    |         |   |        |          |      |                |               |    |         |   |        |          |      |                |               |    |         |   |        |          |      |                |               |    |         |   |        |          |      |                |               |    |         |   |        |          |      |                |               |    |         |   |        |          |      |                |               |    |         |   |        |          |      |                |               |    |         |   |        |          |      |                |               |    |         |   |        |          |
| <b>Exemptions</b>   |                        |               |          |             | <b>Sale History</b>   |               |               |             |           |                            |                  |              |            |             |   |                 |            |          |                |               |             |         |              |        |          |               |                |               |    |          |                   |            |             |      |                |                        |            |           |    |        |                |      |                |               |         |         |        |               |          |          |                |               |    |         |   |        |          |      |                |               |    |         |   |        |          |      |                |               |    |         |   |        |          |      |                |               |    |         |   |        |          |      |                |               |    |         |   |        |          |      |                |               |    |         |   |        |          |      |                |               |    |         |   |        |          |      |                |               |    |         |   |        |          |      |                |               |    |         |   |        |          |
| <table border="1"> <thead> <tr> <th>Code</th> <th>Type</th> <th>Active</th> <th>Maximum</th> <th>Exemption</th> </tr> </thead> <tbody> <tr> <td colspan="5">LOT 4 BLOCK 2 CHERRY ACRES</td> </tr> </tbody> </table>   |                        |               |          |             | Code  | Type          | Active        | Maximum     | Exemption | LOT 4 BLOCK 2 CHERRY ACRES |                  |              |            |             | <table border="1"> <thead> <tr> <th>Bk/Pg</th> <th>Grantor</th> <th>Date</th> <th>Price</th> <th>Code</th> </tr> </thead> <tbody> <tr> <td>2559/308</td> <td>HENLEY, NANCY</td> <td>06/07/2016</td> <td>0</td> <td>4</td> </tr> <tr> <td>1951/749</td> <td>COOK, WILLIAM K &amp;</td> <td>04/25/2008</td> <td>110,000</td> <td>YES</td> </tr> <tr> <td>880/725</td> <td>WILLINGHAM, ROBERT S &amp;</td> <td>04/29/1992</td> <td>42,000</td> <td>No</td> </tr> </tbody> </table> |                 |            |          |                | Bk/Pg         | Grantor     | Date    | Price        | Code   | 2559/308 | HENLEY, NANCY | 06/07/2016     | 0             | 4  | 1951/749 | COOK, WILLIAM K & | 04/25/2008 | 110,000     | YES  | 880/725        | WILLINGHAM, ROBERT S & | 04/29/1992 | 42,000    | No |        |                |      |                |               |         |         |        |               |          |          |                |               |    |         |   |        |          |      |                |               |    |         |   |        |          |      |                |               |    |         |   |        |          |      |                |               |    |         |   |        |          |      |                |               |    |         |   |        |          |      |                |               |    |         |   |        |          |      |                |               |    |         |   |        |          |      |                |               |    |         |   |        |          |      |                |               |    |         |   |        |          |
| Code  | Type                   | Active        | Maximum  | Exemption   |   |               |               |             |           |                            |                  |              |            |             |   |                 |            |          |                |               |             |         |              |        |          |               |                |               |    |          |                   |            |             |      |                |                        |            |           |    |        |                |      |                |               |         |         |        |               |          |          |                |               |    |         |   |        |          |      |                |               |    |         |   |        |          |      |                |               |    |         |   |        |          |      |                |               |    |         |   |        |          |      |                |               |    |         |   |        |          |      |                |               |    |         |   |        |          |      |                |               |    |         |   |        |          |      |                |               |    |         |   |        |          |      |                |               |    |         |   |        |          |
| LOT 4 BLOCK 2 CHERRY ACRES  |                        |               |          |             |   |               |               |             |           |                            |                  |              |            |             |   |                 |            |          |                |               |             |         |              |        |          |               |                |               |    |          |                   |            |             |      |                |                        |            |           |    |        |                |      |                |               |         |         |        |               |          |          |                |               |    |         |   |        |          |      |                |               |    |         |   |        |          |      |                |               |    |         |   |        |          |      |                |               |    |         |   |        |          |      |                |               |    |         |   |        |          |      |                |               |    |         |   |        |          |      |                |               |    |         |   |        |          |      |                |               |    |         |   |        |          |      |                |               |    |         |   |        |          |
| Bk/Pg   | Grantor                | Date          | Price    | Code        |   |               |               |             |           |                            |                  |              |            |             |   |                 |            |          |                |               |             |         |              |        |          |               |                |               |    |          |                   |            |             |      |                |                        |            |           |    |        |                |      |                |               |         |         |        |               |          |          |                |               |    |         |   |        |          |      |                |               |    |         |   |        |          |      |                |               |    |         |   |        |          |      |                |               |    |         |   |        |          |      |                |               |    |         |   |        |          |      |                |               |    |         |   |        |          |      |                |               |    |         |   |        |          |      |                |               |    |         |   |        |          |      |                |               |    |         |   |        |          |
| 2559/308  | HENLEY, NANCY          | 06/07/2016    | 0        | 4           |   |               |               |             |           |                            |                  |              |            |             |   |                 |            |          |                |               |             |         |              |        |          |               |                |               |    |          |                   |            |             |      |                |                        |            |           |    |        |                |      |                |               |         |         |        |               |          |          |                |               |    |         |   |        |          |      |                |               |    |         |   |        |          |      |                |               |    |         |   |        |          |      |                |               |    |         |   |        |          |      |                |               |    |         |   |        |          |      |                |               |    |         |   |        |          |      |                |               |    |         |   |        |          |      |                |               |    |         |   |        |          |      |                |               |    |         |   |        |          |
| 1951/749  | COOK, WILLIAM K &      | 04/25/2008    | 110,000  | YES         |   |               |               |             |           |                            |                  |              |            |             |   |                 |            |          |                |               |             |         |              |        |          |               |                |               |    |          |                   |            |             |      |                |                        |            |           |    |        |                |      |                |               |         |         |        |               |          |          |                |               |    |         |   |        |          |      |                |               |    |         |   |        |          |      |                |               |    |         |   |        |          |      |                |               |    |         |   |        |          |      |                |               |    |         |   |        |          |      |                |               |    |         |   |        |          |      |                |               |    |         |   |        |          |      |                |               |    |         |   |        |          |      |                |               |    |         |   |        |          |
| 880/725   | WILLINGHAM, ROBERT S & | 04/29/1992    | 42,000   | No          |   |               |               |             |           |                            |                  |              |            |             |   |                 |            |          |                |               |             |         |              |        |          |               |                |               |    |          |                   |            |             |      |                |                        |            |           |    |        |                |      |                |               |         |         |        |               |          |          |                |               |    |         |   |        |          |      |                |               |    |         |   |        |          |      |                |               |    |         |   |        |          |      |                |               |    |         |   |        |          |      |                |               |    |         |   |        |          |      |                |               |    |         |   |        |          |      |                |               |    |         |   |        |          |      |                |               |    |         |   |        |          |      |                |               |    |         |   |        |          |
| <b>Parcel Valuation</b>   |                        |               |          |             |   |               |               |             |           |                            |                  |              |            |             |   |                 |            |          |                |               |             |         |              |        |          |               |                |               |    |          |                   |            |             |      |                |                        |            |           |    |        |                |      |                |               |         |         |        |               |          |          |                |               |    |         |   |        |          |      |                |               |    |         |   |        |          |      |                |               |    |         |   |        |          |      |                |               |    |         |   |        |          |      |                |               |    |         |   |        |          |      |                |               |    |         |   |        |          |      |                |               |    |         |   |        |          |      |                |               |    |         |   |        |          |      |                |               |    |         |   |        |          |
| <table border="1"> <thead> <tr> <th>Source</th> <th>REAL</th> <th>Fair Cash</th> <th>Capped</th> <th>Asmnt Level</th> <th>Assessed</th> <th>Levy Rate</th> <th>92.430</th> <th>Current Tax</th> </tr> </thead> <tbody> <tr> <td>Remove Cap</td> <td>2009</td> <td>Land Value</td> <td>56,631</td> <td>51,730</td> <td>11%</td> <td>5,690</td> <td>Assessed</td> <td>14,671</td> <td>1,356.04</td> </tr> <tr> <td>Year Frozen</td> <td>0</td> <td>Improvements</td> <td>81,647</td> <td>81,647</td> <td></td> <td>8,981</td> <td>Penalty</td> <td>0</td> <td></td> </tr> <tr> <td>Uncapped Value</td> <td>0</td> <td>Mobile Home</td> <td>0</td> <td>0</td> <td></td> <td>0</td> <td>Exemption</td> <td>0</td> <td>0.00</td> </tr> <tr> <td>TIF Project ID</td> <td>0</td> <td>Total Value</td> <td>138,278</td> <td>133,377</td> <td></td> <td>14,671</td> <td>Total Taxable</td> <td>14,671</td> <td>1,356.00</td> </tr> </tbody> </table>   |                        | Source        | REAL     | Fair Cash   | Capped  | Asmnt Level   | Assessed      | Levy Rate   | 92.430    | Current Tax                | Remove Cap       | 2009         | Land Value | 56,631      | 51,730  | 11%             | 5,690      | Assessed | 14,671         | 1,356.04      | Year Frozen | 0       | Improvements | 81,647 | 81,647   |               | 8,981          | Penalty       | 0  |          | Uncapped Value    | 0          | Mobile Home | 0    | 0              |                        | 0          | Exemption | 0  | 0.00   | TIF Project ID | 0    | Total Value    | 138,278       | 133,377 |         | 14,671 | Total Taxable | 14,671   | 1,356.00 |                |               |    |         |   |        |          |      |                |               |    |         |   |        |          |      |                |               |    |         |   |        |          |      |                |               |    |         |   |        |          |      |                |               |    |         |   |        |          |      |                |               |    |         |   |        |          |      |                |               |    |         |   |        |          |      |                |               |    |         |   |        |          |      |                |               |    |         |   |        |          |
| Source  | REAL                   | Fair Cash     | Capped   | Asmnt Level | Assessed  | Levy Rate     | 92.430        | Current Tax |           |                            |                  |              |            |             |   |                 |            |          |                |               |             |         |              |        |          |               |                |               |    |          |                   |            |             |      |                |                        |            |           |    |        |                |      |                |               |         |         |        |               |          |          |                |               |    |         |   |        |          |      |                |               |    |         |   |        |          |      |                |               |    |         |   |        |          |      |                |               |    |         |   |        |          |      |                |               |    |         |   |        |          |      |                |               |    |         |   |        |          |      |                |               |    |         |   |        |          |      |                |               |    |         |   |        |          |      |                |               |    |         |   |        |          |
| Remove Cap  | 2009                   | Land Value    | 56,631   | 51,730      | 11%   | 5,690         | Assessed      | 14,671      | 1,356.04  |                            |                  |              |            |             |   |                 |            |          |                |               |             |         |              |        |          |               |                |               |    |          |                   |            |             |      |                |                        |            |           |    |        |                |      |                |               |         |         |        |               |          |          |                |               |    |         |   |        |          |      |                |               |    |         |   |        |          |      |                |               |    |         |   |        |          |      |                |               |    |         |   |        |          |      |                |               |    |         |   |        |          |      |                |               |    |         |   |        |          |      |                |               |    |         |   |        |          |      |                |               |    |         |   |        |          |      |                |               |    |         |   |        |          |
| Year Frozen   | 0                      | Improvements  | 81,647   | 81,647      |   | 8,981         | Penalty       | 0           |           |                            |                  |              |            |             |   |                 |            |          |                |               |             |         |              |        |          |               |                |               |    |          |                   |            |             |      |                |                        |            |           |    |        |                |      |                |               |         |         |        |               |          |          |                |               |    |         |   |        |          |      |                |               |    |         |   |        |          |      |                |               |    |         |   |        |          |      |                |               |    |         |   |        |          |      |                |               |    |         |   |        |          |      |                |               |    |         |   |        |          |      |                |               |    |         |   |        |          |      |                |               |    |         |   |        |          |      |                |               |    |         |   |        |          |
| Uncapped Value  | 0                      | Mobile Home   | 0        | 0           |   | 0             | Exemption     | 0           | 0.00      |                            |                  |              |            |             |   |                 |            |          |                |               |             |         |              |        |          |               |                |               |    |          |                   |            |             |      |                |                        |            |           |    |        |                |      |                |               |         |         |        |               |          |          |                |               |    |         |   |        |          |      |                |               |    |         |   |        |          |      |                |               |    |         |   |        |          |      |                |               |    |         |   |        |          |      |                |               |    |         |   |        |          |      |                |               |    |         |   |        |          |      |                |               |    |         |   |        |          |      |                |               |    |         |   |        |          |      |                |               |    |         |   |        |          |
| TIF Project ID  | 0                      | Total Value   | 138,278  | 133,377     |   | 14,671        | Total Taxable | 14,671      | 1,356.00  |                            |                  |              |            |             |   |                 |            |          |                |               |             |         |              |        |          |               |                |               |    |          |                   |            |             |      |                |                        |            |           |    |        |                |      |                |               |         |         |        |               |          |          |                |               |    |         |   |        |          |      |                |               |    |         |   |        |          |      |                |               |    |         |   |        |          |      |                |               |    |         |   |        |          |      |                |               |    |         |   |        |          |      |                |               |    |         |   |        |          |      |                |               |    |         |   |        |          |      |                |               |    |         |   |        |          |      |                |               |    |         |   |        |          |
| <b>Assessment History</b>   |                        |               |          |             |   |               |               |             |           |                            |                  |              |            |             |   |                 |            |          |                |               |             |         |              |        |          |               |                |               |    |          |                   |            |             |      |                |                        |            |           |    |        |                |      |                |               |         |         |        |               |          |          |                |               |    |         |   |        |          |      |                |               |    |         |   |        |          |      |                |               |    |         |   |        |          |      |                |               |    |         |   |        |          |      |                |               |    |         |   |        |          |      |                |               |    |         |   |        |          |      |                |               |    |         |   |        |          |      |                |               |    |         |   |        |          |      |                |               |    |         |   |        |          |
| <table border="1"> <thead> <tr> <th>Tax Year</th> <th>Statement Number</th> <th>Billed Owner</th> <th>Tax Area</th> <th>Total Value</th> <th>Exemptions</th> <th>Taxable Value</th> <th>Billed Tax</th> </tr> </thead> <tbody> <tr><td>2025</td><td>2025-660003067</td><td>MCGILL, NANCY</td><td>17</td><td>135,954</td><td>0</td><td>13,973</td><td>1,292.00</td></tr> <tr><td>2024</td><td>2024-660003067</td><td>MCGILL, NANCY</td><td>17</td><td>135,024</td><td>0</td><td>13,308</td><td>1,230.00</td></tr> <tr><td>2023</td><td>2023-660003067</td><td>MCGILL, NANCY</td><td>17</td><td>130,003</td><td>0</td><td>12,674</td><td>1,161.00</td></tr> <tr><td>2022</td><td>2022-660003067</td><td>MCGILL, NANCY</td><td>17</td><td>109,732</td><td>0</td><td>12,071</td><td>1,117.00</td></tr> <tr><td>2021</td><td>2021-660003067</td><td>MCGILL, NANCY</td><td>17</td><td>110,508</td><td>0</td><td>12,156</td><td>1,073.00</td></tr> <tr><td>2020</td><td>2020-660003067</td><td>MCGILL, NANCY</td><td>17</td><td>111,440</td><td>0</td><td>12,258</td><td>1,122.00</td></tr> <tr><td>2019</td><td>2019-660003067</td><td>MCGILL, NANCY</td><td>17</td><td>106,596</td><td>0</td><td>11,726</td><td>1,086.00</td></tr> <tr><td>2018</td><td>2018-660003067</td><td>MCGILL, NANCY</td><td>17</td><td>112,075</td><td>0</td><td>12,328</td><td>1,139.00</td></tr> <tr><td>2017</td><td>2017-660003067</td><td>MCGILL, NANCY</td><td>17</td><td>111,231</td><td>0</td><td>12,235</td><td>1,124.00</td></tr> <tr><td>2016</td><td>2016-660003067</td><td>MCGILL, NANCY</td><td>17</td><td>108,731</td><td>0</td><td>11,960</td><td>1,123.00</td></tr> <tr><td>2015</td><td>2015-660003067</td><td>HENLEY, NANCY</td><td>17</td><td>108,916</td><td>0</td><td>11,981</td><td>1,081.00</td></tr> <tr><td>2014</td><td>2014-660003067</td><td>HENLEY, NANCY</td><td>17</td><td>109,678</td><td>0</td><td>11,789</td><td>1,093.00</td></tr> <tr><td>2013</td><td>2013-660003067</td><td>HENLEY, NANCY</td><td>17</td><td>104,652</td><td>0</td><td>11,227</td><td>1,027.00</td></tr> </tbody> </table> |                        |               |          |             |   |               |               |             |           | Tax Year                   | Statement Number | Billed Owner | Tax Area   | Total Value | Exemptions  | Taxable Value   | Billed Tax | 2025     | 2025-660003067 | MCGILL, NANCY | 17          | 135,954 | 0            | 13,973 | 1,292.00 | 2024          | 2024-660003067 | MCGILL, NANCY | 17 | 135,024  | 0                 | 13,308     | 1,230.00    | 2023 | 2023-660003067 | MCGILL, NANCY          | 17         | 130,003   | 0  | 12,674 | 1,161.00       | 2022 | 2022-660003067 | MCGILL, NANCY | 17      | 109,732 | 0      | 12,071        | 1,117.00 | 2021     | 2021-660003067 | MCGILL, NANCY | 17 | 110,508 | 0 | 12,156 | 1,073.00 | 2020 | 2020-660003067 | MCGILL, NANCY | 17 | 111,440 | 0 | 12,258 | 1,122.00 | 2019 | 2019-660003067 | MCGILL, NANCY | 17 | 106,596 | 0 | 11,726 | 1,086.00 | 2018 | 2018-660003067 | MCGILL, NANCY | 17 | 112,075 | 0 | 12,328 | 1,139.00 | 2017 | 2017-660003067 | MCGILL, NANCY | 17 | 111,231 | 0 | 12,235 | 1,124.00 | 2016 | 2016-660003067 | MCGILL, NANCY | 17 | 108,731 | 0 | 11,960 | 1,123.00 | 2015 | 2015-660003067 | HENLEY, NANCY | 17 | 108,916 | 0 | 11,981 | 1,081.00 | 2014 | 2014-660003067 | HENLEY, NANCY | 17 | 109,678 | 0 | 11,789 | 1,093.00 | 2013 | 2013-660003067 | HENLEY, NANCY | 17 | 104,652 | 0 | 11,227 | 1,027.00 |
| Tax Year  | Statement Number       | Billed Owner  | Tax Area | Total Value | Exemptions  | Taxable Value | Billed Tax    |             |           |                            |                  |              |            |             |   |                 |            |          |                |               |             |         |              |        |          |               |                |               |    |          |                   |            |             |      |                |                        |            |           |    |        |                |      |                |               |         |         |        |               |          |          |                |               |    |         |   |        |          |      |                |               |    |         |   |        |          |      |                |               |    |         |   |        |          |      |                |               |    |         |   |        |          |      |                |               |    |         |   |        |          |      |                |               |    |         |   |        |          |      |                |               |    |         |   |        |          |      |                |               |    |         |   |        |          |      |                |               |    |         |   |        |          |
| 2025  | 2025-660003067         | MCGILL, NANCY | 17       | 135,954     | 0   | 13,973        | 1,292.00      |             |           |                            |                  |              |            |             |   |                 |            |          |                |               |             |         |              |        |          |               |                |               |    |          |                   |            |             |      |                |                        |            |           |    |        |                |      |                |               |         |         |        |               |          |          |                |               |    |         |   |        |          |      |                |               |    |         |   |        |          |      |                |               |    |         |   |        |          |      |                |               |    |         |   |        |          |      |                |               |    |         |   |        |          |      |                |               |    |         |   |        |          |      |                |               |    |         |   |        |          |      |                |               |    |         |   |        |          |      |                |               |    |         |   |        |          |
| 2024  | 2024-660003067         | MCGILL, NANCY | 17       | 135,024     | 0   | 13,308        | 1,230.00      |             |           |                            |                  |              |            |             |   |                 |            |          |                |               |             |         |              |        |          |               |                |               |    |          |                   |            |             |      |                |                        |            |           |    |        |                |      |                |               |         |         |        |               |          |          |                |               |    |         |   |        |          |      |                |               |    |         |   |        |          |      |                |               |    |         |   |        |          |      |                |               |    |         |   |        |          |      |                |               |    |         |   |        |          |      |                |               |    |         |   |        |          |      |                |               |    |         |   |        |          |      |                |               |    |         |   |        |          |      |                |               |    |         |   |        |          |
| 2023  | 2023-660003067         | MCGILL, NANCY | 17       | 130,003     | 0   | 12,674        | 1,161.00      |             |           |                            |                  |              |            |             |   |                 |            |          |                |               |             |         |              |        |          |               |                |               |    |          |                   |            |             |      |                |                        |            |           |    |        |                |      |                |               |         |         |        |               |          |          |                |               |    |         |   |        |          |      |                |               |    |         |   |        |          |      |                |               |    |         |   |        |          |      |                |               |    |         |   |        |          |      |                |               |    |         |   |        |          |      |                |               |    |         |   |        |          |      |                |               |    |         |   |        |          |      |                |               |    |         |   |        |          |      |                |               |    |         |   |        |          |
| 2022  | 2022-660003067         | MCGILL, NANCY | 17       | 109,732     | 0   | 12,071        | 1,117.00      |             |           |                            |                  |              |            |             |   |                 |            |          |                |               |             |         |              |        |          |               |                |               |    |          |                   |            |             |      |                |                        |            |           |    |        |                |      |                |               |         |         |        |               |          |          |                |               |    |         |   |        |          |      |                |               |    |         |   |        |          |      |                |               |    |         |   |        |          |      |                |               |    |         |   |        |          |      |                |               |    |         |   |        |          |      |                |               |    |         |   |        |          |      |                |               |    |         |   |        |          |      |                |               |    |         |   |        |          |      |                |               |    |         |   |        |          |
| 2021  | 2021-660003067         | MCGILL, NANCY | 17       | 110,508     | 0   | 12,156        | 1,073.00      |             |           |                            |                  |              |            |             |   |                 |            |          |                |               |             |         |              |        |          |               |                |               |    |          |                   |            |             |      |                |                        |            |           |    |        |                |      |                |               |         |         |        |               |          |          |                |               |    |         |   |        |          |      |                |               |    |         |   |        |          |      |                |               |    |         |   |        |          |      |                |               |    |         |   |        |          |      |                |               |    |         |   |        |          |      |                |               |    |         |   |        |          |      |                |               |    |         |   |        |          |      |                |               |    |         |   |        |          |      |                |               |    |         |   |        |          |
| 2020  | 2020-660003067         | MCGILL, NANCY | 17       | 111,440     | 0   | 12,258        | 1,122.00      |             |           |                            |                  |              |            |             |   |                 |            |          |                |               |             |         |              |        |          |               |                |               |    |          |                   |            |             |      |                |                        |            |           |    |        |                |      |                |               |         |         |        |               |          |          |                |               |    |         |   |        |          |      |                |               |    |         |   |        |          |      |                |               |    |         |   |        |          |      |                |               |    |         |   |        |          |      |                |               |    |         |   |        |          |      |                |               |    |         |   |        |          |      |                |               |    |         |   |        |          |      |                |               |    |         |   |        |          |      |                |               |    |         |   |        |          |
| 2019  | 2019-660003067         | MCGILL, NANCY | 17       | 106,596     | 0   | 11,726        | 1,086.00      |             |           |                            |                  |              |            |             |   |                 |            |          |                |               |             |         |              |        |          |               |                |               |    |          |                   |            |             |      |                |                        |            |           |    |        |                |      |                |               |         |         |        |               |          |          |                |               |    |         |   |        |          |      |                |               |    |         |   |        |          |      |                |               |    |         |   |        |          |      |                |               |    |         |   |        |          |      |                |               |    |         |   |        |          |      |                |               |    |         |   |        |          |      |                |               |    |         |   |        |          |      |                |               |    |         |   |        |          |      |                |               |    |         |   |        |          |
| 2018  | 2018-660003067         | MCGILL, NANCY | 17       | 112,075     | 0   | 12,328        | 1,139.00      |             |           |                            |                  |              |            |             |   |                 |            |          |                |               |             |         |              |        |          |               |                |               |    |          |                   |            |             |      |                |                        |            |           |    |        |                |      |                |               |         |         |        |               |          |          |                |               |    |         |   |        |          |      |                |               |    |         |   |        |          |      |                |               |    |         |   |        |          |      |                |               |    |         |   |        |          |      |                |               |    |         |   |        |          |      |                |               |    |         |   |        |          |      |                |               |    |         |   |        |          |      |                |               |    |         |   |        |          |      |                |               |    |         |   |        |          |
| 2017  | 2017-660003067         | MCGILL, NANCY | 17       | 111,231     | 0   | 12,235        | 1,124.00      |             |           |                            |                  |              |            |             |   |                 |            |          |                |               |             |         |              |        |          |               |                |               |    |          |                   |            |             |      |                |                        |            |           |    |        |                |      |                |               |         |         |        |               |          |          |                |               |    |         |   |        |          |      |                |               |    |         |   |        |          |      |                |               |    |         |   |        |          |      |                |               |    |         |   |        |          |      |                |               |    |         |   |        |          |      |                |               |    |         |   |        |          |      |                |               |    |         |   |        |          |      |                |               |    |         |   |        |          |      |                |               |    |         |   |        |          |
| 2016  | 2016-660003067         | MCGILL, NANCY | 17       | 108,731     | 0   | 11,960        | 1,123.00      |             |           |                            |                  |              |            |             |   |                 |            |          |                |               |             |         |              |        |          |               |                |               |    |          |                   |            |             |      |                |                        |            |           |    |        |                |      |                |               |         |         |        |               |          |          |                |               |    |         |   |        |          |      |                |               |    |         |   |        |          |      |                |               |    |         |   |        |          |      |                |               |    |         |   |        |          |      |                |               |    |         |   |        |          |      |                |               |    |         |   |        |          |      |                |               |    |         |   |        |          |      |                |               |    |         |   |        |          |      |                |               |    |         |   |        |          |
| 2015  | 2015-660003067         | HENLEY, NANCY | 17       | 108,916     | 0   | 11,981        | 1,081.00      |             |           |                            |                  |              |            |             |   |                 |            |          |                |               |             |         |              |        |          |               |                |               |    |          |                   |            |             |      |                |                        |            |           |    |        |                |      |                |               |         |         |        |               |          |          |                |               |    |         |   |        |          |      |                |               |    |         |   |        |          |      |                |               |    |         |   |        |          |      |                |               |    |         |   |        |          |      |                |               |    |         |   |        |          |      |                |               |    |         |   |        |          |      |                |               |    |         |   |        |          |      |                |               |    |         |   |        |          |      |                |               |    |         |   |        |          |
| 2014  | 2014-660003067         | HENLEY, NANCY | 17       | 109,678     | 0   | 11,789        | 1,093.00      |             |           |                            |                  |              |            |             |   |                 |            |          |                |               |             |         |              |        |          |               |                |               |    |          |                   |            |             |      |                |                        |            |           |    |        |                |      |                |               |         |         |        |               |          |          |                |               |    |         |   |        |          |      |                |               |    |         |   |        |          |      |                |               |    |         |   |        |          |      |                |               |    |         |   |        |          |      |                |               |    |         |   |        |          |      |                |               |    |         |   |        |          |      |                |               |    |         |   |        |          |      |                |               |    |         |   |        |          |      |                |               |    |         |   |        |          |
| 2013  | 2013-660003067         | HENLEY, NANCY | 17       | 104,652     | 0   | 11,227        | 1,027.00      |             |           |                            |                  |              |            |             |   |                 |            |          |                |               |             |         |              |        |          |               |                |               |    |          |                   |            |             |      |                |                        |            |           |    |        |                |      |                |               |         |         |        |               |          |          |                |               |    |         |   |        |          |      |                |               |    |         |   |        |          |      |                |               |    |         |   |        |          |      |                |               |    |         |   |        |          |      |                |               |    |         |   |        |          |      |                |               |    |         |   |        |          |      |                |               |    |         |   |        |          |      |                |               |    |         |   |        |          |      |                |               |    |         |   |        |          |



# Rogers

## Assessment Property Record Card for Tax Year 2026

Data provided by LISA DELOZIER County Assessor

Date 04/17/2026  
Time 03:23:59  
Page 2

| Lot Data        | Square-Foot - NBHD 1162 #1 | Primary Image |
|-----------------|----------------------------|---------------|
| Lot Size        |                            |               |
| Lot Count       | 1                          |               |
| Units Buildable | 1                          |               |
| Non-Ag Acres    | 0.2386                     |               |
| Topography      |                            |               |
| Street Access   |                            |               |
| Utilities       |                            |               |
| Amenities       | LAND QUALITY               |               |
|                 | 0                          |               |
|                 | 0                          |               |
| Method          | Square-Foot                |               |
| Base Lot Value  | 10,391.00 x 5.45 = 56,631  |               |
| Factor Value    |                            |               |
| Adjustments     | 1.0000                     |               |
| Lot Value       | 56,631                     |               |

| Residential Data |  |
|------------------|--|
| Type             | 1 Single Family Residence                    |
| Condition        | 3 - Average                                  |
| Quality          | 2.5 - Fair                                   |
| Architecture     | R3 Res Nbhd 3                                |
| Style            | 100% One Story                               |
| Exterior Wall    | 10% Veneer, Masonry 90% Frame, Siding, Vinyl |
| Base/Total Area  | 1,547 / 1,547                                |
| Style            | 100% One Story                               |
| HVAC             | 100% Warmed & Cooled Air                     |
| Roof Cover       | 1 Composition Shingle                        |
| Area on Slab     | 1,547  |
| Fixture/RghIn    | 8 /  |
| Bed/F/H Bath     | 3 / 2.0 /                                    |
| Basement Area    |  |
| Garage Type      | 192 Attached Garage - Unfinished             |
| Remodel          |  |
| Year/Eff Age     | 1957 / 52                                    |

| Cost Approach |           | Manual : 01/2025    |           |
|---------------|-----------|---------------------|-----------|
| Base Cost     | 97.69     | Total Misc Impr     | + 3,146   |
| Roofing Adj   | + 4.48    | Garage Cost         | + 6,787   |
| Subfloor Adj  | + -1.15   | Total RCN           | = 194,397 |
| Heat/Cool Adj | + 11.47   | Depreciation ( 58%) | - 112,750 |
| Plumbing Adj  | + 6.75    | Lump Sums           | + 0       |
| Basement Adj  | + 0.00    | RCNLD               | = 81,647  |
| Adj Base Cost | = 119.24  | Lot Value           | + 56,631  |
| Total Area    | x 1,547   | Indicated Value     | = 138,278 |
| Adjusted Cost | = 184,464 | Value Per SqFt      | 89.38     |

| GRM Approach    |      |
|-----------------|------|
| GRM Code        |      |
| Gross Rent      | 0.00 |
| Indicated Value |      |

| Multiple Regression |                        |
|---------------------|------------------------|
| MRA Code            | 1 Test                 |
| Adusted R           | 0.8445                 |
| Indicated Value     | 119,160 77.03 Per SqFt |

| Direct Comparables |                    |
|--------------------|--------------------|
| Selection Model    | A Adam Test        |
| Adjustment Model   | 1 2022 Residential |
| Comparables        | 8                  |
| Indicated Value    | 173,610 Per SqFt   |

| Value Reconciliation |                                    |
|----------------------|------------------------------------|
| Selected Approach    | Cost Approach                      |
| Improvements         | 81,647                             |
| Lot Value            | 56,631                             |
| Indicated Value      | 138,278 89.38 Per SqFt             |
| Agland Value         |                                    |
| Site Improvements    |                                    |
| Total Value          | 138,278 89.38 Total Value Per SqFt |

| Miscellaneous Improvements |                      |           |      |      |       |           |            |
|----------------------------|----------------------|-----------|------|------|-------|-----------|------------|
| Code                       | Description          | Sketch ID | Size | Year | Units | Unit Cost | Depr Value |
| PRCH                       | SLAB PORCH - COVERED | 7764      | 33x4 |      | 132   | 23.83     | 3,146      |



# Rogers

## Assessment Property Record Card for Tax Year 2026

Data provided by LISA DELOZIER County Assessor

Date 04/17/2026

Time 03:23:59

Page 3

Sketch Image

660003067

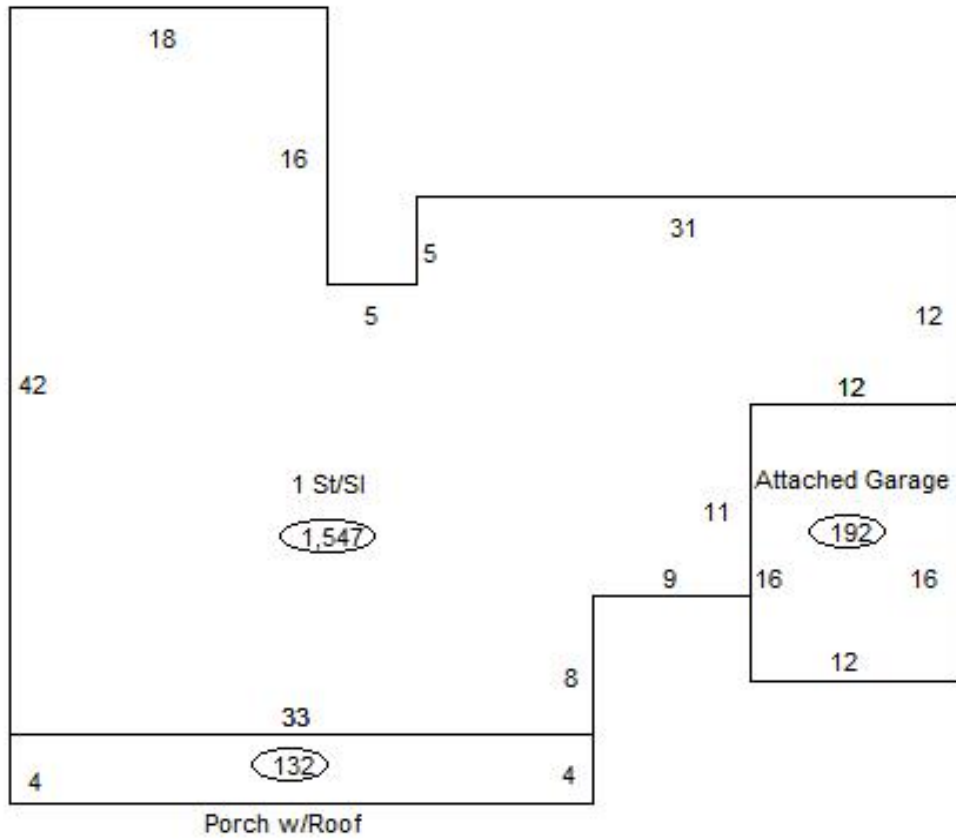

### Sketch Vector Information

| Sequence                   | Code | Type | Built Over | Scale | Section Label   | Base Area | Multiplier | Total Area |
|----------------------------|------|------|------------|-------|-----------------|-----------|------------|------------|
| 1                          | R    | 1    | Slab       | 13    | 1 St/SI         | 1,547     | 1.000      | 1,547      |
| 2                          | G    | 1    |            | 13    | Attached Garage | 192       | 1.000      | 192        |
| 3                          | M    | PRCH |            | 13    | SLBC            | 132       | 1.000      | 132        |
| <b>Total Building Area</b> |      |      |            |       |                 | 1,547     |            | 1,547      |



# Rogers

## Assessment Property Record Card for Tax Year 2026

Data provided by LISA DELOZIER County Assessor

Date 04/17/2026  
Time 03:23:59  
Page 4

660003067

### Outbuildings/Site Improvements

| Building Image   | Code | Description         | Dimensions            | Floor      | Roofing                       | Total Units  |
|--|------|---------------------|-----------------------|------------|-------------------------------|--------------|
|  | STF  | STG FAIR            | 0x0x0                 |            |                               |              |
|  | Qual | 2                   | Cond                  | Year       | Eff Age                       |              |
| <b>Valuation Summary</b>   |      |                     | <b>Modifier Total</b> | <b>RCN</b> | <b>Depr (0% Phys/ % Func)</b> | <b>RCNLD</b> |
|  |      | Base Cost (4.68 x ) |                       |            |                               |              |