



# Rogers

## Assessment Property Record Card for Tax Year 2026

Data provided by LISA DELOZIER County Assessor

Date 04/17/2026  
 Time 09:12:12  
 Page 1

Assessment Data					Primary Image																																																																																																																				
Account 660006239 Parcel ID 000000-00-0-10475-017-0014 Cadastral ID 07-21-16-05740 Property Type REAL - Real Property Property Class URP VI Area 1 Tax Area 17 - CLAREMORE OT Name ID 306795 BUDGICK, JASON D  616 ROSEWOOD CIR CLAREMORE OK 74017-0000  <b>Parcel Location</b> Situs 00616 ROSEWOOD CIR Subdivision WESTWOOD ESTATES II Lot/Block 0014 / 0017 Parcel Size 1 - Lots Sec/Twn/Rng 7 / 21 / 16 / 5 Neighborhood 1180 - R-V01-SW CLAREMORE School District S001 - CLAREMORE SCHOOLS																																																																																																																									
<b>Legal Description</b> Lot/Long: 36.30807632 -95.63952013																																																																																																																									
<b>Legal Description</b> LOT 14 BLOCK 17 WESTWOOD ESTATES II					<b>Building Permits</b> <table border="1"> <thead> <tr> <th>Number</th> <th>Description</th> <th>Opened</th> <th>Closed</th> <th>Amount</th> </tr> </thead> <tbody> <tr> <td> </td> <td> </td> <td> </td> <td> </td> <td> </td> </tr> </tbody> </table>					Number	Description	Opened	Closed	Amount																																																																																																											
Number	Description	Opened	Closed	Amount																																																																																																																					
<b>Exemptions</b> <table border="1"> <thead> <tr> <th>Code</th> <th>Type</th> <th>Active</th> <th>Maximum</th> <th>Exemption</th> </tr> </thead> <tbody> <tr> <td>H</td> <td>Homestead</td> <td>Yes</td> <td>1,000</td> <td>1,000</td> </tr> </tbody> </table>					Code	Type	Active	Maximum	Exemption	H	Homestead	Yes	1,000	1,000	<b>Sale History</b> <table border="1"> <thead> <tr> <th>Bk/Pg</th> <th>Grantor</th> <th>Date</th> <th>Price</th> <th>Code</th> </tr> </thead> <tbody> <tr> <td>2239/706</td> <td>CASE, ROBERT E SR &amp;</td> <td>04/20/2012</td> <td>98,000</td> <td>YES</td> </tr> <tr> <td>1819/440</td> <td>KNOWLES, JEFFREY J</td> <td>10/30/2006</td> <td>0</td> <td>4</td> </tr> <tr> <td>1819/441</td> <td>KNOWLES, JEANETTA-ELIZABETH</td> <td>10/30/2006</td> <td>70,500</td> <td>YES</td> </tr> <tr> <td>1093/499</td> <td>HIGHTOWER, ALAN L</td> <td>12/22/1997</td> <td>72,500</td> <td>Yes</td> </tr> </tbody> </table>					Bk/Pg	Grantor	Date	Price	Code	2239/706	CASE, ROBERT E SR &	04/20/2012	98,000	YES	1819/440	KNOWLES, JEFFREY J	10/30/2006	0	4	1819/441	KNOWLES, JEANETTA-ELIZABETH	10/30/2006	70,500	YES	1093/499	HIGHTOWER, ALAN L	12/22/1997	72,500	Yes																																																																													
Code	Type	Active	Maximum	Exemption																																																																																																																					
H	Homestead	Yes	1,000	1,000																																																																																																																					
Bk/Pg	Grantor	Date	Price	Code																																																																																																																					
2239/706	CASE, ROBERT E SR &	04/20/2012	98,000	YES																																																																																																																					
1819/440	KNOWLES, JEFFREY J	10/30/2006	0	4																																																																																																																					
1819/441	KNOWLES, JEANETTA-ELIZABETH	10/30/2006	70,500	YES																																																																																																																					
1093/499	HIGHTOWER, ALAN L	12/22/1997	72,500	Yes																																																																																																																					
<b>Parcel Valuation</b> <table border="1"> <thead> <tr> <th>Source</th> <th>REAL</th> <th>Fair Cash</th> <th>Capped</th> <th>Asmnt Level</th> <th>Assessed</th> <th>Levy Rate</th> <th>92.430</th> <th>Current Tax</th> </tr> </thead> <tbody> <tr> <td>Remove Cap</td> <td>2013</td> <td>Land Value 45,285</td> <td>26,936</td> <td>11%</td> <td>2,963</td> <td>Assessed</td> <td>15,366</td> <td>1,420.28</td> </tr> <tr> <td>Year Frozen</td> <td>0</td> <td>Improvements 121,510</td> <td>112,759</td> <td></td> <td>12,403</td> <td>Penalty</td> <td>0</td> <td></td> </tr> <tr> <td>Uncapped Value</td> <td>0</td> <td>Mobile Home 0</td> <td>0</td> <td></td> <td>0</td> <td>Exemption</td> <td>1,000</td> <td>-92.00</td> </tr> <tr> <td>TIF Project ID</td> <td>0</td> <td>Total Value 166,795</td> <td>139,695</td> <td></td> <td>15,366</td> <td>Total Taxable</td> <td>14,366</td> <td>1,328.00</td> </tr> </tbody> </table>										Source	REAL	Fair Cash	Capped	Asmnt Level	Assessed	Levy Rate	92.430	Current Tax	Remove Cap	2013	Land Value 45,285	26,936	11%	2,963	Assessed	15,366	1,420.28	Year Frozen	0	Improvements 121,510	112,759		12,403	Penalty	0		Uncapped Value	0	Mobile Home 0	0		0	Exemption	1,000	-92.00	TIF Project ID	0	Total Value 166,795	139,695		15,366	Total Taxable	14,366	1,328.00																																																																			
Source	REAL	Fair Cash	Capped	Asmnt Level	Assessed	Levy Rate	92.430	Current Tax																																																																																																																	
Remove Cap	2013	Land Value 45,285	26,936	11%	2,963	Assessed	15,366	1,420.28																																																																																																																	
Year Frozen	0	Improvements 121,510	112,759		12,403	Penalty	0																																																																																																																		
Uncapped Value	0	Mobile Home 0	0		0	Exemption	1,000	-92.00																																																																																																																	
TIF Project ID	0	Total Value 166,795	139,695		15,366	Total Taxable	14,366	1,328.00																																																																																																																	
<b>Assessment History</b> <table border="1"> <thead> <tr> <th>Tax Year</th> <th>Statement Number</th> <th>Billed Owner</th> <th>Tax Area</th> <th>Total Value</th> <th>Exemptions</th> <th>Taxable Value</th> <th>Billed Tax</th> </tr> </thead> <tbody> <tr><td>2025</td><td>2025-660006239</td><td>BUDGICK, JASON D</td><td>17</td><td>162,842</td><td>1000</td><td>13,919</td><td>1,287.00</td></tr> <tr><td>2024</td><td>2024-660006239</td><td>BUDGICK, JASON D</td><td>17</td><td>171,427</td><td>1000</td><td>13,485</td><td>1,246.00</td></tr> <tr><td>2023</td><td>2023-660006239</td><td>BUDGICK, JASON D</td><td>17</td><td>150,951</td><td>1000</td><td>13,063</td><td>1,197.00</td></tr> <tr><td>2022</td><td>2022-660006239</td><td>BUDGICK, JASON D</td><td>17</td><td>124,119</td><td>1000</td><td>12,653</td><td>1,171.00</td></tr> <tr><td>2021</td><td>2021-660006239</td><td>BUDGICK, JASON D</td><td>17</td><td>128,433</td><td>1000</td><td>13,128</td><td>1,159.00</td></tr> <tr><td>2020</td><td>2020-660006239</td><td>BUDGICK, JASON D</td><td>17</td><td>126,377</td><td>1000</td><td>12,818</td><td>1,174.00</td></tr> <tr><td>2019</td><td>2019-660006239</td><td>BUDGICK, JASON D</td><td>17</td><td>121,962</td><td>1000</td><td>12,416</td><td>1,150.00</td></tr> <tr><td>2018</td><td>2018-660006239</td><td>BUDGICK, JASON D</td><td>17</td><td>127,222</td><td>1000</td><td>12,994</td><td>1,201.00</td></tr> <tr><td>2017</td><td>2017-660006239</td><td>BUDGICK, JASON D</td><td>17</td><td>126,177</td><td>1000</td><td>12,879</td><td>1,183.00</td></tr> <tr><td>2016</td><td>2016-660006239</td><td>BUDGICK, JASON D</td><td>17</td><td>123,037</td><td>1000</td><td>12,534</td><td>1,176.00</td></tr> <tr><td>2015</td><td>2015-660006239</td><td>BUDGICK, JASON D</td><td>17</td><td>121,895</td><td>1000</td><td>12,408</td><td>1,119.00</td></tr> <tr><td>2014</td><td>2014-660006239</td><td>BUDGICK, JASON D</td><td>17</td><td>122,886</td><td>1000</td><td>12,138</td><td>1,126.00</td></tr> <tr><td>2013</td><td>2013-660006239</td><td>BUDGICK, JASON D</td><td>17</td><td>115,960</td><td>1000</td><td>11,756</td><td>1,076.00</td></tr> </tbody> </table>										Tax Year	Statement Number	Billed Owner	Tax Area	Total Value	Exemptions	Taxable Value	Billed Tax	2025	2025-660006239	BUDGICK, JASON D	17	162,842	1000	13,919	1,287.00	2024	2024-660006239	BUDGICK, JASON D	17	171,427	1000	13,485	1,246.00	2023	2023-660006239	BUDGICK, JASON D	17	150,951	1000	13,063	1,197.00	2022	2022-660006239	BUDGICK, JASON D	17	124,119	1000	12,653	1,171.00	2021	2021-660006239	BUDGICK, JASON D	17	128,433	1000	13,128	1,159.00	2020	2020-660006239	BUDGICK, JASON D	17	126,377	1000	12,818	1,174.00	2019	2019-660006239	BUDGICK, JASON D	17	121,962	1000	12,416	1,150.00	2018	2018-660006239	BUDGICK, JASON D	17	127,222	1000	12,994	1,201.00	2017	2017-660006239	BUDGICK, JASON D	17	126,177	1000	12,879	1,183.00	2016	2016-660006239	BUDGICK, JASON D	17	123,037	1000	12,534	1,176.00	2015	2015-660006239	BUDGICK, JASON D	17	121,895	1000	12,408	1,119.00	2014	2014-660006239	BUDGICK, JASON D	17	122,886	1000	12,138	1,126.00	2013	2013-660006239	BUDGICK, JASON D	17	115,960	1000	11,756	1,076.00
Tax Year	Statement Number	Billed Owner	Tax Area	Total Value	Exemptions	Taxable Value	Billed Tax																																																																																																																		
2025	2025-660006239	BUDGICK, JASON D	17	162,842	1000	13,919	1,287.00																																																																																																																		
2024	2024-660006239	BUDGICK, JASON D	17	171,427	1000	13,485	1,246.00																																																																																																																		
2023	2023-660006239	BUDGICK, JASON D	17	150,951	1000	13,063	1,197.00																																																																																																																		
2022	2022-660006239	BUDGICK, JASON D	17	124,119	1000	12,653	1,171.00																																																																																																																		
2021	2021-660006239	BUDGICK, JASON D	17	128,433	1000	13,128	1,159.00																																																																																																																		
2020	2020-660006239	BUDGICK, JASON D	17	126,377	1000	12,818	1,174.00																																																																																																																		
2019	2019-660006239	BUDGICK, JASON D	17	121,962	1000	12,416	1,150.00																																																																																																																		
2018	2018-660006239	BUDGICK, JASON D	17	127,222	1000	12,994	1,201.00																																																																																																																		
2017	2017-660006239	BUDGICK, JASON D	17	126,177	1000	12,879	1,183.00																																																																																																																		
2016	2016-660006239	BUDGICK, JASON D	17	123,037	1000	12,534	1,176.00																																																																																																																		
2015	2015-660006239	BUDGICK, JASON D	17	121,895	1000	12,408	1,119.00																																																																																																																		
2014	2014-660006239	BUDGICK, JASON D	17	122,886	1000	12,138	1,126.00																																																																																																																		
2013	2013-660006239	BUDGICK, JASON D	17	115,960	1000	11,756	1,076.00																																																																																																																		



# Rogers

## Assessment Property Record Card for Tax Year 2026

Data provided by LISA DELOZIER County Assessor

Date 04/17/2026  
 Time 09:12:12  
 Page 2

Lot Data		Square-Foot - NBHD 1180 #1	
Lot Size			
Lot Count	1		
Units Buildable	15840		
Non-Ag Acres	0.2505		
Topography			
Street Access			
Utilities			
Amenities		0	
		0	
Method	Square-Foot		
Base Lot Value	10,912.00 x 4.15 = 45,285		
Factor Value			
Adjustments	1.0000		
Lot Value	45,285		



\\tsclient\T\LOGAN\LOGAN RESIDENTIAL VI\2023-5-5\IMG\_0019. 5/5/2023

Residential Data	
Type	1 Single Family Residence
Condition	3 - Average
Quality	2.5 - Fair
Architecture	R3 Res Nbhd 3
Style	100% One Story
Exterior Wall	100% Veneer, Masonry
Base/Total Area	1,656 / 1,656
Style	100% One Story
HVAC	100% Warmed & Cooled Air
Roof Cover	1 Composition Shingle
Area on Slab	1,656
Fixture/RghIn	8 /
Bed/F/H Bath	3 / 2.0 /
Basement Area	
Garage Type	475 Attached Garage - Unfinished 2 Stalls
Remodel	
Year/Eff Age	1975 / 38

GRM Approach	
GRM Code	
Gross Rent	0.00
Indicated Value	

Multiple Regression			
MRA Code	1	Test	
Adusted R	0.8445		
Indicated Value	166,145	100.33	Per SqFt

Direct Comparables			
Selection Model	A	Adam Test	
Adjustment Model	1	2022 Residential	
Comparables	8		
Indicated Value	199,930		Per SqFt

Cost Approach				Manual : 01/2025			
Base Cost	104.79	Total Misc Impr	+	7,687			
Roofing Adj	+ 4.43	Garage Cost	+	13,186			
Subfloor Adj	+ -1.15	Total RCN	=	229,264			
Heat/Cool Adj	+ 11.47	Depreciation ( 47%)	-	107,754			
Plumbing Adj	+ 6.30	Lump Sums	+	0			
Basement Adj	+ 0.00	RCNLD	=	121,510			
Adj Base Cost	= 125.84	Lot Value	+	45,285			
Total Area	x 1,656	Indicated Value	=	166,795			
Adjusted Cost	= 208,391	Value Per SqFt		100.72			

Value Reconciliation			
Selected Approach	Cost Approach		
Improvements	121,510		
Lot Value	45,285		
Indicated Value	166,795	100.72	Per SqFt
Agland Value			
Site Improvements			
Total Value	166,795	100.72	Total Value Per SqFt

Miscellaneous Improvements								
Code	Description	Sketch ID	Size	Year	Units	Unit Cost	Depr	Value
FPR1	FIREPLACE - RESIDENTIAL 1 STORY	0		1	1	5,095.98		5,096
PRCH	SLAB PORCH - COVERED	15089	6x4		24	24.19		581
PATO	SLAB PORCH - OPEN	15090	202		202	9.95		2,010



**Rogers**  
**Assessment Property Record Card for Tax Year 2026**

Data provided by LISA DELOZIER County Assessor

Date 04/17/2026  
 Time 09:12:12  
 Page 3

Sketch Image

660006239

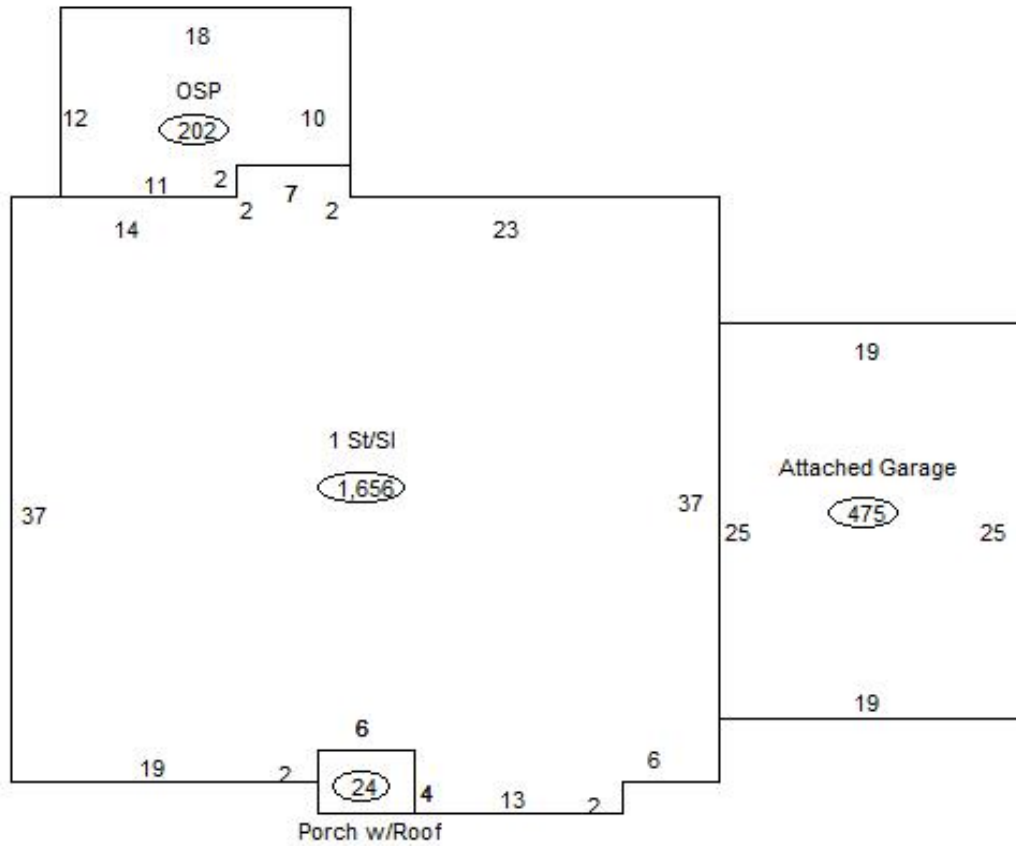

**Sketch Vector Information**

Sequence	Code	Type	Built Over	Scale	Section Label	Base Area	Multiplier	Total Area
1	R	1	Slab	13	1 St/Sl	1,656	1.000	1,656
2	G	1		13	Attached Garage	475	1.000	475
3	M	PRCH		13	SLBC	24	1.000	24
4	M	PATO		13	Open Slab	202	1.000	202
<b>Total Building Area</b>						1,656		1,656