



# Rogers

## Assessment Property Record Card for Tax Year 2026

Data provided by LISA DELOZIER County Assessor

Date 04/16/2026  
Time 23:25:14  
Page 1

### Assessment Data

Account 660015169  
Parcel ID 000000-00-0-10080-002-0025  
Cadastral ID 16-21-16-02170  
Property Type REAL - Real Property  
Property Class URP VI Area 1  
Tax Area 17 - CLAREMORE OT  
Name ID 348004  
HARRIS, ALEC & TAYLOR

PO BOX 621  
OWASSO OK 74055-0000

#### Parcel Location

Situs 00521 S CHICKASAW AVE  
Subdivision DENNISON  
Lot/Block 0025 / 0002 Parcel Size 2 - Lots  
Sec/Twn/Rng 16 / 21 / 16 / 5  
Neighborhood 1161 - R-V01-SW CLAREMORE  
School District S001 - CLAREMORE SCHOOLS

### Primary Image



\\tsclient\T\LOGAN\LOGAN RESIDENTIAL VI\2023-8-11\IMG\_0011 8/11/2023

### Legal Description

Lat/Long: 36.30672069 -95.61284963

LOTS 24 & 25 BLOCK 2 DENNISON

### Building Permits

Number	Description	Opened	Closed	Amount

### Exemptions

Code	Type	Active	Maximum	Exemption
HV	Veteran	Yes	999,999	21,464
H	Homestead	No	1,000	

### Sale History

Bk/Pg	Grantor	Date	Price	Code
/	PALMETTO INVESTMENTS LLC	08/28/2025	195,000	YES
/	BEASLEY, SHAROLE LOUISE	04/22/2024	105,000	19
1502/841	BEASLEY, GARY GLENN	07/29/2003	0	4
976/290	RAGLAND, JOEL S &	12/13/1994	47,500	Yes
947/577	BELL, HENRY W	02/18/1994	30,000	No
822/667			4,500	No

### Parcel Valuation

Source	REAL	Fair Cash	Capped	Asmnt Level	Assessed	Levy Rate	92.430	Current Tax
Remove Cap	2026	Land Value 64,747	64,747	11%	7,122	Assessed	21,464	1,983.92
Year Frozen	0	Improvements 130,386	130,386		14,342	Penalty	0	
Uncapped Value	0	Mobile Home 0	0		0	Exemption	21,464	-1,984.00
TIF Project ID	0	Total Value 195,133	195,133		21,464	Total Taxable	0	0.00

### Assessment History

Tax Year	Statement Number	Billed Owner	Tax Area	Total Value	Exemptions	Taxable Value	Billed Tax
2025	2025-660015169	HARRIS, ALEC & TAYLOR	17	128,782	0	14,166	1,309.00
2024	2024-660015169	PALMETTO INVESTMENTS LLC	17	137,844	1000	6,489	600.00
2023	2023-660015169	BEASLEY, SHAROLE LOUISE	17	82,524	1000	6,272	575.00
2022	2022-660015169	BEASLEY, SHAROLE LOUISE	17	66,690	1000	6,061	561.00
2021	2021-660015169	BEASLEY, SHAROLE LOUISE	17	62,313	1000	5,855	517.00
2020	2020-660015169	BEASLEY, SHAROLE LOUISE	17	61,645	1000	5,781	529.00
2019	2019-660015169	BEASLEY, SHAROLE LOUISE	17	56,891	1000	5,258	487.00
2018	2018-660015169	BEASLEY, SHAROLE LOUISE	17	60,678	1000	5,675	524.00
2017	2017-660015169	BEASLEY, SHAROLE LOUISE	17	60,296	1000	5,633	517.00
2016	2016-660015169	BEASLEY, SHAROLE LOUISE	17	59,034	1000	5,487	515.00
2015	2015-660015169	BEASLEY, SHAROLE LOUISE	17	58,022	1000	5,298	478.00
2014	2014-660015169	BEASLEY, SHAROLE LOUISE	17	59,504	1000	5,115	474.00
2013	2013-660015169	BEASLEY, SHAROLE LOUISE	17	59,946	1000	4,937	452.00



# Rogers

## Assessment Property Record Card for Tax Year 2026

Data provided by LISA DELOZIER County Assessor

Date 04/16/2026  
 Time 23:25:14  
 Page 2

Lot Data		Square-Foot - NBHD 1161 #1	
Lot Size			
Lot Count	1		
Units Buildable	1		
Non-Ag Acres	0.2859		
Topography			
Street Access			
Utilities			
Amenities	LAND QUALITY	0	
		0	
Method	Square-Foot		
Base Lot Value	12,452.00 x 5.39 = 67,130		
Factor Value			
Adjustments	0.9645		
Lot Value	64,747		



\\tsclient\T\LOGAN\LOGAN RESIDENTIAL VI\2023-8-11\IMG\_001I 8/11/2023

Residential Data	
Type	1 Single Family Residence
Condition	3 - Average
Quality	2.5 - Fair
Architecture	R3 Res Nbhd 3
Style	100% 1 1/2 Story Finished
Exterior Wall	25% Veneer, Stone 75% Frame, Siding, Wood
Base/Total Area	928 / 1,512
Style	100% 1 1/2 Story Finished
HVAC	100% Floor Furnace
Roof Cover	1 Composition Shingle
Area on Slab	0
Fixture/RghIn	8 /
Bed/F/H Bath	3 / 2.0 /
Basement Area	
Garage Type	
Remodel	REVITALIZE -
Year/Eff Age	1940 / 23

GRM Approach	
GRM Code	
Gross Rent	0.00
Indicated Value	

Multiple Regression	
MRA Code	1 Test
Adjusted R	0.8445
Indicated Value	100,914 66.74 Per SqFt

Direct Comparables	
Selection Model	A Adam Test
Adjustment Model	1 2022 Residential
Comparables	2
Indicated Value	116,660 Per SqFt

Cost Approach		Manual : 01/2025	
Base Cost	85.73	Total Misc Impr	+ 18,513
Roofing Adj	+ 2.95	Garage Cost	+
Subfloor Adj	+ 0.75	Total RCN	= 166,961
Heat/Cool Adj	+ 1.84	Depreciation ( 30%)	- 50,088
Plumbing Adj	+ 6.91	Lump Sums	+ 0
Basement Adj	+ 0.00	RCNLD	= 116,873
Adj Base Cost	= 98.18	Lot Value	+ 64,747
Total Area	x 1,512	Indicated Value	= 181,620
Adjusted Cost	= 148,448	Value Per SqFt	120.12

Value Reconciliation	
Selected Approach	Cost Approach
Improvements	116,873
Lot Value	64,747
Indicated Value	181,620 120.12 Per SqFt
Agland Value	
Site Improvements	13,513
Total Value	195,133 129.06 Total Value Per SqFt

Miscellaneous Improvements								
Code	Description	Sketch ID	Size	Year	Units	Unit Cost	Depr	Value
PRCH	SLAB PORCH - COVERED	36423	27x6		162	23.71		3,841
EPSW	ENCLOSED PORCH - SOLID WALL	36424	25x6		150	62.47		9,371
EPSW	ENCLOSED PORCH - SOLID WALL	142412	12x7		84	63.11		5,301



# Rogers

## Assessment Property Record Card for Tax Year 2026

Data provided by LISA DELOZIER County Assessor

Date 04/16/2026  
 Time 23:25:14  
 Page 3

Sketch Image

660015169

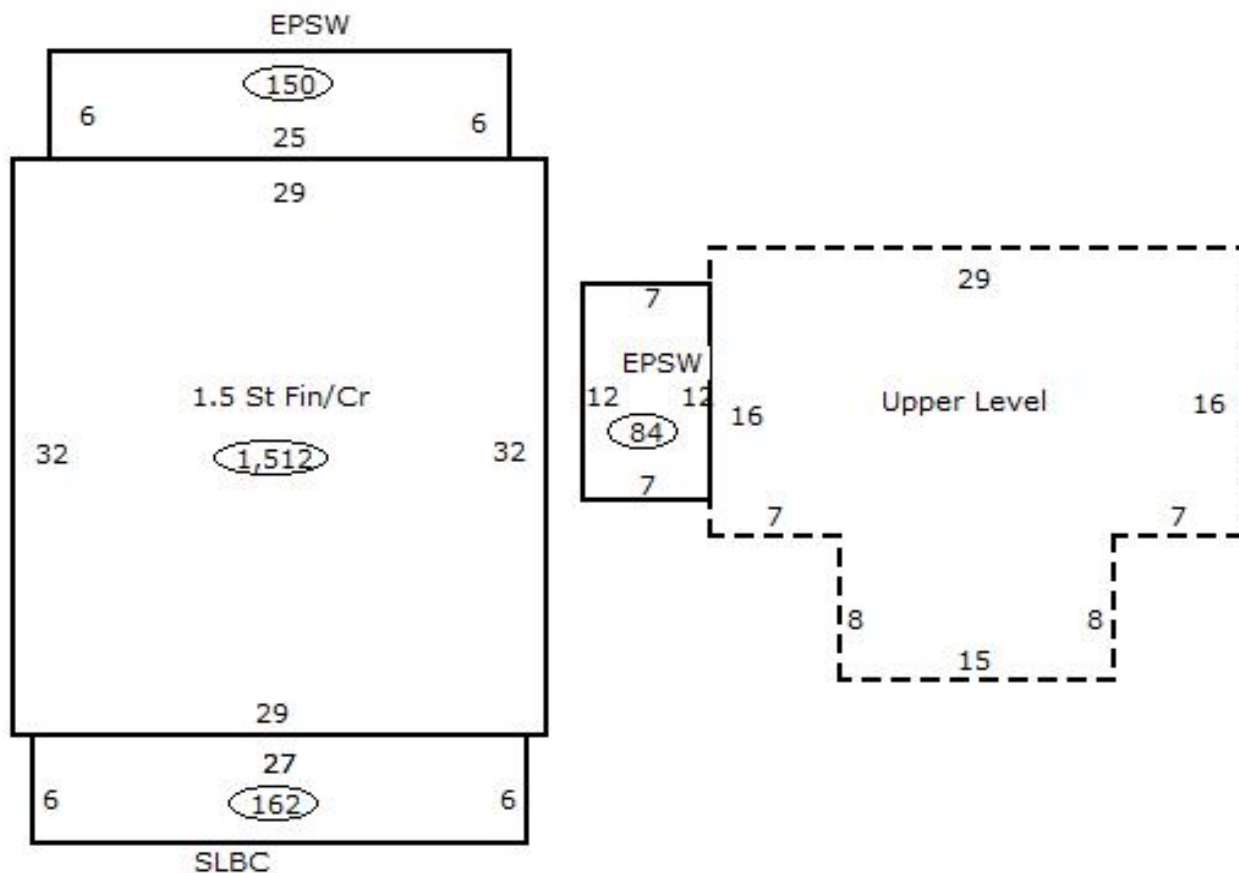

### Sketch Vector Information

Sequence	Code	Type	Built Over	Scale	Section Label	Base Area	Multiplier	Total Area
1	R	5	Crawl	13	1.5 St Fin/Cr	928	1.629	1,512
2	M	PRCH		13	SLBC	162	1.000	162
3	M	EPSW		13	EPSW	150	1.000	150
4	U	^UL	Overhang	13	Upper Level	584	1.000	584
5	M	EPSW		13	EPSW	84	1.000	84
<b>Total Building Area</b>						928		1,512



# Rogers

## Assessment Property Record Card for Tax Year 2026

Data provided by LISA DELOZIER County Assessor

Date 04/16/2026  
Time 23:25:14  
Page 4

660015169

### Outbuildings/Site Improvements

Building Image	Code	Description	Dimensions	Floor	Roofing	Total Units
	UTIL	SHOP BUILDING	0x0x0			864
	Qual 2	Cond 3	Year	Eff Age		
<b>Valuation Summary</b>		<b>Modifier Total</b>	<b>RCN</b>	<b>Depr (50% Phys/ % Func)</b>	<b>RCNLD</b>	
Base Cost (31.28 x 864)		27,026	27,026	13,513	13,513	