



Rogers

Assessment Property Record Card for Tax Year 2026

Data provided by LISA DELOZIER County Assessor

Date 04/16/2026
Time 23:02:04
Page 1

Assessment Data					Primary Image				
Account	660017002								
Parcel ID	22N17E-18-1-00000-000-0000								
Cadastral ID	18-22-17-00700								
Property Type	REAL - Real Property								
Property Class	RR	VI Area 2							
Tax Area	75 - SEQUOYAH/FOYIL FD								
Name ID	307534								
MOORE, JEREMIAH & MARISSA									
11852 HICKORY LN CLAREMORE OK 74017-0000									
Parcel Location									
Situs	15471 S 4195 RD								
Subdivision									
Lot/Block	/	Parcel Size	5.11 - Acres						
Sec/Twn/Rng	18 / 22 / 17 / 1								
Neighborhood	4070 - FOYIL SEQUOYAH AREA								
School District	S006 - SEQUOYAH SCHOOLS								
Legal Description Lat/Long: 36.38753441 -95.53208164									
E 1026' OF S2 S2 SW NE & S 30' OF S2 S2 SW NE LESS E 1026' THEREOF. AND LESS TR DESC 2021-023080 AS COMM SW/C NE; N88 3618E 939.29' TO POB; N88.3618E 377.40'; N01.2711W 329.67'; S88 3634W 377.40'; S01.2710E 329.70' TO POB.									
Building Permits									
Number	Description	Opened	Closed	Amount					
R22	R23- NEW ADDRESS	02/2022	04/2023						
Exemptions									
Code	Type	Active	Maximum	Exemption					
H	Homestead	Yes	1,000	1,000					
Sale History									
Bk/Pg	Grantor	Date	Price	Code					
2260/532	HADDOCK, JUSTIN W	07/17/2012	219,000	YES					
1461/503	HOPE, BOB B &	03/19/2003	32,000	YES					
Parcel Valuation									
Source	REAL	Fair Cash	Capped	Asmnt Level	Assessed	Levy Rate	101.310	Current Tax	
Remove Cap	2013	Land Value	77,719	61,939	11%	6,813	Assessed	46,129 4,673.33	
Year Frozen	0	Improvements	362,565	357,422		39,316	Penalty	0	
Uncapped Value	0	Mobile Home	0	0		0	Exemption	1,000 -88.00	
TIF Project ID	0	Total Value	440,284	419,361		46,129	Total Taxable	45,129 4,585.00	
Assessment History									
Tax Year	Statement Number	Billed Owner	Tax Area	Total Value	Exemptions	Taxable Value	Billed Tax		
2025	2025-660017002	MOORE, JEREMIAH & MARISSA	75	407,147	1000	43,786	4,449.00		
2024	2024-660017002	MOORE, JEREMIAH & MARISSA	75	428,934	1000	44,392	4,536.00		
2023	2023-660017002	MOORE, JEREMIAH & MARISSA	75	42,580	0	4,684	488.00		
2022	2022-660017002	MOORE, JEREMIAH & MARISSA	75	42,580	0	4,684	498.00		
2021	2021-660017002	MOORE, JEREMIAH & MARISSA	75	271,254	1000	27,387	2,843.00		
2020	2020-660017002	MOORE, JEREMIAH & MARISSA	75	262,858	1000	26,560	2,859.00		
2019	2019-660017002	MOORE, JEREMIAH & MARISSA	75	243,250	1000	25,757	2,750.00		
2018	2018-660017002	MOORE, JEREMIAH & MARISSA	75	249,048	1000	26,395	2,832.00		
2017	2017-660017002	MOORE, JEREMIAH & MARISSA	75	247,220	1000	26,194	2,792.00		
2016	2016-660017002	MOORE, JEREMIAH & MARISSA	75	241,512	1000	25,566	2,721.00		
2015	2015-660017002	MOORE, JEREMIAH & MARISSA	75	236,442	0	26,009	2,801.00		
2014	2014-660017002	MOORE, JEREMIAH & MARISSA	75	236,113	0	25,793	2,816.00		
2013	2013-660017002	MOORE, JEREMIAH & MARISSA	75	223,318	0	24,565	2,620.00		



Rogers

Assessment Property Record Card for Tax Year 2026

Data provided by LISA DELOZIER County Assessor

Date 04/16/2026
 Time 23:02:04
 Page 2

Lot Data		Square-Foot - NBHD 4070 #1	
Lot Size	0	0	
Lot Count	0		
Units Buildable	0		
Non-Ag Acres	5.1368		
Topography			
Street Access			
Utilities			
Amenities	LAND QUALITY		0
			0
Method	Square-Foot		
Base Lot Value	223,757.00 x .35 = 77,719		
Factor Value			
Adjustments	1.0000		
Lot Value	77,719		



\\tsclient\T\ROB STUFF\2023-4-18\IMG_0001.JPG 4/18/2023

Residential Data	
Type	1 Single Family Residence
Condition	3 - Average
Quality	3.5 - Average
Architecture	TRAD TRADITIONAL
Style	100% One Story
Exterior Wall	100% Veneer, Masonry
Base/Total Area	2,434 / 2,434
Style	100% One Story
HVAC	100% Warmed & Cooled Air
Roof Cover	1 Composition Shingle
Area on Slab	2,434
Fixture/RghIn	/
Bed/F/H Bath	3 / 2.0 /
Basement Area	
Garage Type	802 Attached Garage - Finished
Remodel	
Year/Eff Age	2023 / 2

GRM Approach	
GRM Code	
Gross Rent	0.00
Indicated Value	

Multiple Regression	
MRA Code	
Adjusted R	
Indicated Value	

Direct Comparables	
Selection Model	1 Res
Adjustment Model	A2 AO Test
Comparables	
Indicated Value	

Cost Approach		Manual : 01/2025	
Base Cost	109.07	Total Misc Impr	+ 14,289
Roofing Adj	+ 5.19	Garage Cost	+ 37,405
Subfloor Adj	+ -3.39	Total RCN	= 369,964
Heat/Cool Adj	+ 14.47	Depreciation (2%)	- 7,399
Plumbing Adj	+ 5.42	Lump Sums	+ 0
Basement Adj	+ 0.00	RCNLD	= 362,565
Adj Base Cost	= 130.76	Lot Value	+ 77,719
Total Area	x 2,434	Indicated Value	= 440,284
Adjusted Cost	= 318,270	Value Per SqFt	180.89

Value Reconciliation			
Selected Approach	Cost Approach		
Improvements	362,565		
Lot Value	77,719		
Indicated Value	440,284	180.89	Per SqFt
Agland Value			
Site Improvements			
Total Value	440,284	180.89	Total Value Per SqFt

Miscellaneous Improvements								
Code	Description	Sketch ID	Size	Year	Units	Unit Cost	Depr	Value
PRCH	Slab Porch - Covered	156824	180		180	28.88		5,198
PRCH	Slab Porch - Covered	156825	20x16		320	28.41		9,091



Rogers
Assessment Property Record Card for Tax Year 2026

Data provided by LISA DELOZIER County Assessor

Date 04/16/2026
 Time 23:02:04
 Page 3

Sketch Image

660017002

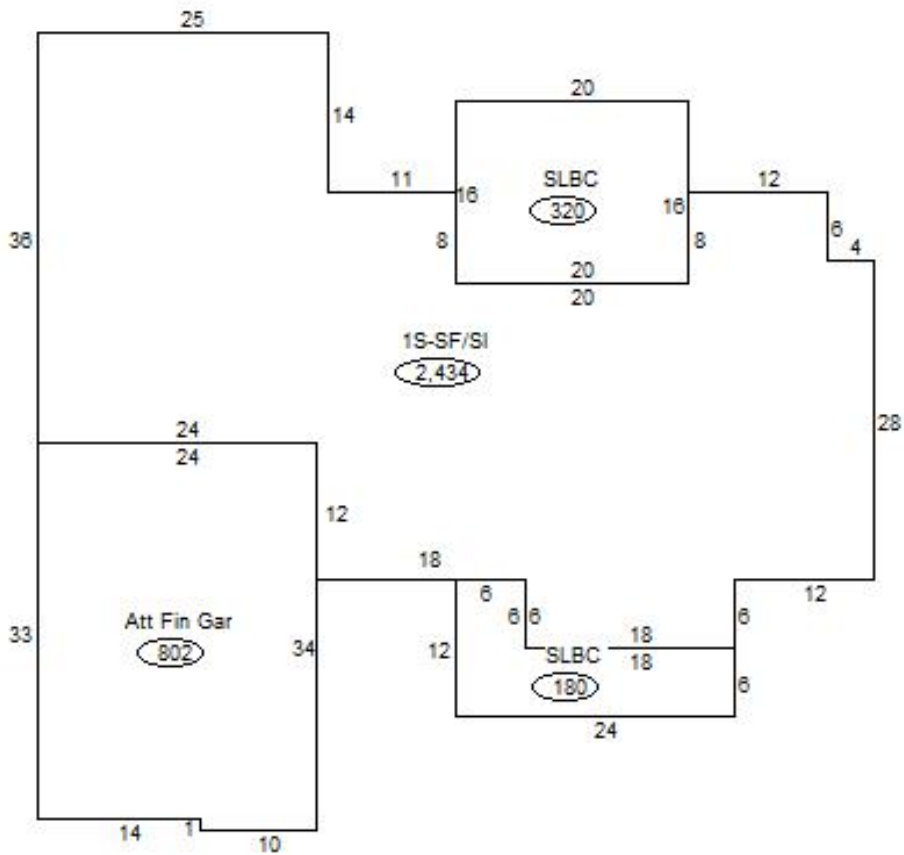

Sketch Vector Information

Sequence	Code	Type	Built Over	Scale	Section Label	Base Area	Multiplier	Total Area
1	R	1	Slab	20	1S-SF/Sl	2,434	1.000	2,434
2	G	5		20	Att Fin Gar	802	1.000	802
3	M	PRCH		20	SLBC	180	1.000	180
4	M	PRCH		20	SLBC	320	1.000	320
Total Building Area						2,434		2,434



Rogers

Assessment Property Record Card for Tax Year 2026

Data provided by LISA DELOZIER County Assessor

Date 04/16/2026
Time 23:02:04
Page 4

660017002

Outbuildings/Site Improvements

Building Image	Code	Description	Dimensions	Floor	Roofing	Total Units
	SHDS	Shed - Small	0x0x0	Base		
	Qual	3	Cond	Year	2023	Eff Age
		Valuation Summary	Modifier Total	RCN	Depr (0% Phys/ % Func)	RCNLD
		Base Cost (39.31 x)				