



Rogers

Assessment Property Record Card for Tax Year 2026

Data provided by LISA DELOZIER County Assessor

Date 04/17/2026
 Time 04:27:42
 Page 1

Assessment Data					Primary Image																																																																																																																				
Account 660018032 Parcel ID 19N17E-20-2-00000-000-0000 Cadastral ID 20-19-17-00610 Property Type REAL - Real Property Property Class RR VI Area 3 Tax Area 2 - INOLA RURAL Name ID 328659 PEREZ, SALVADOR GONZALEZ & MA DE LOS ANGELES GONZALEZ HERNANDEZ 21055 E 40TH PL S BROKEN ARROW OK 74014-0000 Parcel Location Situs 34477 S 4200 RD Subdivision Lot/Block / Parcel Size 2.5 - Acres Sec/Twn/Rng 20 / 19 / 17 / 2 Neighborhood 1917 - UNPLATTED School District S005 - INOLA SCHOOLS					<p>660018032 11/13/25</p> <p>660018032_005.JPG 11/16/2025</p>																																																																																																																				
Legal Description S2 S2 SW SW NW Lat/Long: 36.11182534 -95.52837052																																																																																																																									
Building Permits <table border="1"> <thead> <tr> <th>Number</th> <th>Description</th> <th>Opened</th> <th>Closed</th> <th>Amount</th> </tr> </thead> <tbody> <tr> <td colspan="5"> </td> </tr> </tbody> </table>					Number	Description	Opened	Closed	Amount																																																																																																																
Number	Description	Opened	Closed	Amount																																																																																																																					
Exemptions <table border="1"> <thead> <tr> <th>Code</th> <th>Type</th> <th>Active</th> <th>Maximum</th> <th>Exemption</th> </tr> </thead> <tbody> <tr> <td>H</td> <td>Homestead</td> <td>No</td> <td>1,000</td> <td></td> </tr> <tr> <td>H</td> <td>Homestead</td> <td>No</td> <td>1,000</td> <td></td> </tr> </tbody> </table>					Code	Type	Active	Maximum	Exemption	H	Homestead	No	1,000		H	Homestead	No	1,000		Sale History <table border="1"> <thead> <tr> <th>Bk/Pg</th> <th>Grantor</th> <th>Date</th> <th>Price</th> <th>Code</th> </tr> </thead> <tbody> <tr> <td>/</td> <td>SALVADOR GONZALEZ AND PAOLA G</td> <td>10/21/2019</td> <td></td> <td></td> </tr> <tr> <td>/</td> <td>GONZALEZ, SALVADOR & PAOLA</td> <td>08/16/2019</td> <td>0</td> <td>4</td> </tr> <tr> <td>2584/790</td> <td>CLASSIC COUNTRY HOMES INC</td> <td>10/12/2016</td> <td>40,000</td> <td>YES</td> </tr> <tr> <td>2573/732</td> <td>21ST MORTGAGE CORP</td> <td>08/24/2016</td> <td>20,000</td> <td>3</td> </tr> <tr> <td>2531/398</td> <td>WATKINS, JERRY L & LEA ANN</td> <td>02/16/2016</td> <td>0</td> <td>3</td> </tr> <tr> <td>2359/547</td> <td>HIBBARD, BRADLEY DON &</td> <td>09/27/2013</td> <td>45,000</td> <td>YES</td> </tr> </tbody> </table>					Bk/Pg	Grantor	Date	Price	Code	/	SALVADOR GONZALEZ AND PAOLA G	10/21/2019			/	GONZALEZ, SALVADOR & PAOLA	08/16/2019	0	4	2584/790	CLASSIC COUNTRY HOMES INC	10/12/2016	40,000	YES	2573/732	21ST MORTGAGE CORP	08/24/2016	20,000	3	2531/398	WATKINS, JERRY L & LEA ANN	02/16/2016	0	3	2359/547	HIBBARD, BRADLEY DON &	09/27/2013	45,000	YES																																																														
Code	Type	Active	Maximum	Exemption																																																																																																																					
H	Homestead	No	1,000																																																																																																																						
H	Homestead	No	1,000																																																																																																																						
Bk/Pg	Grantor	Date	Price	Code																																																																																																																					
/	SALVADOR GONZALEZ AND PAOLA G	10/21/2019																																																																																																																							
/	GONZALEZ, SALVADOR & PAOLA	08/16/2019	0	4																																																																																																																					
2584/790	CLASSIC COUNTRY HOMES INC	10/12/2016	40,000	YES																																																																																																																					
2573/732	21ST MORTGAGE CORP	08/24/2016	20,000	3																																																																																																																					
2531/398	WATKINS, JERRY L & LEA ANN	02/16/2016	0	3																																																																																																																					
2359/547	HIBBARD, BRADLEY DON &	09/27/2013	45,000	YES																																																																																																																					
Parcel Valuation <table border="1"> <thead> <tr> <th>Source</th> <th>REAL</th> <th>Fair Cash</th> <th>Capped</th> <th>Asmnt Level</th> <th>Assessed</th> <th>Levy Rate</th> <th>80.060</th> <th>Current Tax</th> </tr> </thead> <tbody> <tr> <td>Remove Cap</td> <td>2017</td> <td>Land Value</td> <td>76,908</td> <td>39,696</td> <td>11%</td> <td>4,367</td> <td>Assessed</td> <td>7,210 577.23</td> </tr> <tr> <td>Year Frozen</td> <td>0</td> <td>Improvements</td> <td>28,734</td> <td>9,153</td> <td></td> <td>1,006</td> <td>Penalty</td> <td>0</td> </tr> <tr> <td>Uncapped Value</td> <td>0</td> <td>Mobile Home</td> <td>25,975</td> <td>16,701</td> <td></td> <td>1,837</td> <td>Exemption</td> <td>0 0.00</td> </tr> <tr> <td>TIF Project ID</td> <td>0</td> <td>Total Value</td> <td>131,617</td> <td>65,550</td> <td></td> <td>7,210</td> <td>Total Taxable</td> <td>7,210 577.00</td> </tr> </tbody> </table>										Source	REAL	Fair Cash	Capped	Asmnt Level	Assessed	Levy Rate	80.060	Current Tax	Remove Cap	2017	Land Value	76,908	39,696	11%	4,367	Assessed	7,210 577.23	Year Frozen	0	Improvements	28,734	9,153		1,006	Penalty	0	Uncapped Value	0	Mobile Home	25,975	16,701		1,837	Exemption	0 0.00	TIF Project ID	0	Total Value	131,617	65,550		7,210	Total Taxable	7,210 577.00																																																																			
Source	REAL	Fair Cash	Capped	Asmnt Level	Assessed	Levy Rate	80.060	Current Tax																																																																																																																	
Remove Cap	2017	Land Value	76,908	39,696	11%	4,367	Assessed	7,210 577.23																																																																																																																	
Year Frozen	0	Improvements	28,734	9,153		1,006	Penalty	0																																																																																																																	
Uncapped Value	0	Mobile Home	25,975	16,701		1,837	Exemption	0 0.00																																																																																																																	
TIF Project ID	0	Total Value	131,617	65,550		7,210	Total Taxable	7,210 577.00																																																																																																																	
Assessment History <table border="1"> <thead> <tr> <th>Tax Year</th> <th>Statement Number</th> <th>Billed Owner</th> <th>Tax Area</th> <th>Total Value</th> <th>Exemptions</th> <th>Taxable Value</th> <th>Billed Tax</th> </tr> </thead> <tbody> <tr><td>2025</td><td>2025-660018032</td><td>PEREZ, SALVADOR GONZALEZ &</td><td>2</td><td>111,238</td><td>0</td><td>6,868</td><td>550.00</td></tr> <tr><td>2024</td><td>2024-660018032</td><td>PEREZ, SALVADOR GONZALEZ &</td><td>2</td><td>125,943</td><td>0</td><td>6,540</td><td>526.00</td></tr> <tr><td>2023</td><td>2023-660018032</td><td>PEREZ, SALVADOR GONZALEZ &</td><td>2</td><td>120,758</td><td>0</td><td>6,229</td><td>502.00</td></tr> <tr><td>2022</td><td>2022-660018032</td><td>PEREZ, SALVADOR GONZALEZ &</td><td>2</td><td>94,515</td><td>0</td><td>5,933</td><td>481.00</td></tr> <tr><td>2021</td><td>2021-660018032</td><td>PEREZ, SALVADOR GONZALEZ &</td><td>2</td><td>59,354</td><td>0</td><td>5,650</td><td>453.00</td></tr> <tr><td>2020</td><td>2020-660018032</td><td>PEREZ, SALVADOR GONZALEZ &</td><td>2</td><td>54,922</td><td>0</td><td>5,381</td><td>435.00</td></tr> <tr><td>2019</td><td>2019-660018032</td><td>PEREZ, SALVADOR GONZALEZ &</td><td>2</td><td>48,979</td><td>0</td><td>5,124</td><td>423.00</td></tr> <tr><td>2018</td><td>2018-660018032</td><td>GONZALEZ, SALVADOR & PAOLA</td><td>2</td><td>44,633</td><td>0</td><td>4,881</td><td>407.00</td></tr> <tr><td>2017</td><td>2017-660018032</td><td>GONZALEZ, SALVADOR & PAOLA</td><td>2</td><td>42,258</td><td>0</td><td>4,648</td><td>391.00</td></tr> <tr><td>2016</td><td>2016-660018032</td><td>CLASSIC COUNTRY HOMES INC</td><td>2</td><td>23,698</td><td>1000</td><td>1,607</td><td>137.00</td></tr> <tr><td>2015</td><td>2015-660018032</td><td>WATKINS, JERRY L & LEA ANN</td><td>2</td><td>23,682</td><td>1000</td><td>1,605</td><td>139.00</td></tr> <tr><td>2014</td><td>2014-660018032</td><td>WATKINS, JERRY L & LEA ANN</td><td>2</td><td>23,698</td><td>1000</td><td>1,607</td><td>144.00</td></tr> <tr><td>2013</td><td>2013-660018032</td><td>WATKINS, JERRY L & LEA ANN</td><td>2</td><td>25,546</td><td>1000</td><td>1,810</td><td>152.00</td></tr> </tbody> </table>										Tax Year	Statement Number	Billed Owner	Tax Area	Total Value	Exemptions	Taxable Value	Billed Tax	2025	2025-660018032	PEREZ, SALVADOR GONZALEZ &	2	111,238	0	6,868	550.00	2024	2024-660018032	PEREZ, SALVADOR GONZALEZ &	2	125,943	0	6,540	526.00	2023	2023-660018032	PEREZ, SALVADOR GONZALEZ &	2	120,758	0	6,229	502.00	2022	2022-660018032	PEREZ, SALVADOR GONZALEZ &	2	94,515	0	5,933	481.00	2021	2021-660018032	PEREZ, SALVADOR GONZALEZ &	2	59,354	0	5,650	453.00	2020	2020-660018032	PEREZ, SALVADOR GONZALEZ &	2	54,922	0	5,381	435.00	2019	2019-660018032	PEREZ, SALVADOR GONZALEZ &	2	48,979	0	5,124	423.00	2018	2018-660018032	GONZALEZ, SALVADOR & PAOLA	2	44,633	0	4,881	407.00	2017	2017-660018032	GONZALEZ, SALVADOR & PAOLA	2	42,258	0	4,648	391.00	2016	2016-660018032	CLASSIC COUNTRY HOMES INC	2	23,698	1000	1,607	137.00	2015	2015-660018032	WATKINS, JERRY L & LEA ANN	2	23,682	1000	1,605	139.00	2014	2014-660018032	WATKINS, JERRY L & LEA ANN	2	23,698	1000	1,607	144.00	2013	2013-660018032	WATKINS, JERRY L & LEA ANN	2	25,546	1000	1,810	152.00
Tax Year	Statement Number	Billed Owner	Tax Area	Total Value	Exemptions	Taxable Value	Billed Tax																																																																																																																		
2025	2025-660018032	PEREZ, SALVADOR GONZALEZ &	2	111,238	0	6,868	550.00																																																																																																																		
2024	2024-660018032	PEREZ, SALVADOR GONZALEZ &	2	125,943	0	6,540	526.00																																																																																																																		
2023	2023-660018032	PEREZ, SALVADOR GONZALEZ &	2	120,758	0	6,229	502.00																																																																																																																		
2022	2022-660018032	PEREZ, SALVADOR GONZALEZ &	2	94,515	0	5,933	481.00																																																																																																																		
2021	2021-660018032	PEREZ, SALVADOR GONZALEZ &	2	59,354	0	5,650	453.00																																																																																																																		
2020	2020-660018032	PEREZ, SALVADOR GONZALEZ &	2	54,922	0	5,381	435.00																																																																																																																		
2019	2019-660018032	PEREZ, SALVADOR GONZALEZ &	2	48,979	0	5,124	423.00																																																																																																																		
2018	2018-660018032	GONZALEZ, SALVADOR & PAOLA	2	44,633	0	4,881	407.00																																																																																																																		
2017	2017-660018032	GONZALEZ, SALVADOR & PAOLA	2	42,258	0	4,648	391.00																																																																																																																		
2016	2016-660018032	CLASSIC COUNTRY HOMES INC	2	23,698	1000	1,607	137.00																																																																																																																		
2015	2015-660018032	WATKINS, JERRY L & LEA ANN	2	23,682	1000	1,605	139.00																																																																																																																		
2014	2014-660018032	WATKINS, JERRY L & LEA ANN	2	23,698	1000	1,607	144.00																																																																																																																		
2013	2013-660018032	WATKINS, JERRY L & LEA ANN	2	25,546	1000	1,810	152.00																																																																																																																		



Rogers

Assessment Property Record Card for Tax Year 2026

Data provided by LISA DELOZIER County Assessor

Date 04/17/2026
 Time 04:27:42
 Page 2

Lot Data		Square-Foot - NBHD 1917 #1		Primary Image				
Lot Size				<p>660018032 11/13/25</p> <p>660018032_005.JPG 11/16/2025</p>				
Lot Count								
Units Buildable	1							
Non-Ag Acres	2.7496							
Topography								
Street Access								
Utilities								
Amenities	LAND QUALITY 1							
	FLOOD ZONE							
Method	Square-Foot							
Base Lot Value	119,773.00 x .51 = 61,526							
Factor Value	15,382							
Adjustments								
Lot Value	76,908							
Residential Data								
Type								
Condition	-							
Quality	-							
Architecture								
Style								
Exterior Wall								
Base/Total Area	/							
Style								
HVAC								
Roof Cover								
Area on Slab								
Fixture/RghIn	/							
Bed/F/H Bath	//							
Basement Area								
Garage Type								
Remodel								
Year/Eff Age	/							
Cost Approach		Manual : 01/2025						
Base Cost	0.00	Total Misc Impr	+	0				
Roofing Adj	+ 0.00	Garage Cost	+					
Subfloor Adj	+ 0.00	Total RCN	=	0				
Heat/Cool Adj	+ 0.00	Depreciation (0%)	-	0				
Plumbing Adj	+ 0.00	Lump Sums	+	0				
Basement Adj	+ 0.00	RCNLD	=					
Adj Base Cost	= 0.00	Lot Value	+	76,908				
Total Area	x	Indicated Value	=	76,908				
Adjusted Cost	= 0	Value Per SqFt		0.00				
Miscellaneous Improvements								
Code	Description	Sketch ID	Size	Year	Units	Unit Cost	Depr	Value

660018032

11/13/25

660018032_005.JPG

11/16/2025

GRM Approach

GRM Code	
Gross Rent	0.00
Indicated Value	

Multiple Regression

MRA Code	
Adjusted R	
Indicated Value	

Direct Comparables

Selection Model	1 Res
Adjustment Model	A2 AO Test
Comparables	
Indicated Value	

Value Reconciliation

Selected Approach	Cost Approach		
Improvements			
Lot Value	76,908		
Indicated Value	76,908	0.00	Per SqFt
Agland Value			
Site Improvements	18,962		
Total Value	95,870	0.00	Total Value Per SqFt



Rogers

Assessment Property Record Card for Tax Year 2026

Data provided by LISA DELOZIER County Assessor

Date 04/17/2026
 Time 04:27:42
 Page 3

660018032

Outbuildings/Site Improvements

Building Image	Code	Description	Dimensions	Floor	Roofing	Total Units
	BNGP	Barn - General Purpose	16x30x10	Dirt	Formed Metal	480
	Qual	3	Cond 3	Year 2010	Eff Age 12	
	Valuation Summary		Modifier Total	RCN	Depr (25% Phys/ % Func)	
	Base Cost (22.54 x 480)	10,819		10,819	2,705	8,114
	LNT0	LEAN-TO (AATT TO BARN)	10x30x8	Dirt	Formed Metal	300
	Qual	3	Cond 3	Year 2010	Eff Age 12	
	Valuation Summary		Modifier Total	RCN	Depr (52% Phys/ % Func)	
	Base Cost (9.44 x 300)	2,832		2,832	1,473	1,359
	BNGP	Barn - General Purpose	20x22x10	Dirt	Formed Metal	440
	Qual	3	Cond 3	Year 2005	Eff Age 16	
	Valuation Summary		Modifier Total	RCN	Depr (37% Phys/ % Func)	
	Base Cost (23.53 x 440)	10,353		10,353	3,831	6,522
	HAYS	Hay Shed Open Sides	14x20x10	Dirt	Formed Metal	280
	Qual	3	Cond 3	Year 2000	Eff Age 20	
	Valuation Summary		Modifier Total	RCN	Depr (53% Phys/ % Func)	
	Base Cost (9.57 x 280)	2,680		2,680	1,420	1,260
	CPDT	Carport - Detached	24x34x10	Dirt	Formed Metal	816
	Qual	3	Cond 3	Year 2000	Eff Age 20	
	Valuation Summary		Modifier Total	RCN	Depr (69% Phys/ % Func)	
	Base Cost (6.75 x 816)	5,508		5,508	3,801	1,707



Rogers

Assessment Property Record Card for Tax Year 2026

Data provided by LISA DELOZIER County Assessor

Date 04/17/2026
 Time 04:27:43
 Page 4

Lot Data	Primary Image
Lot Size Lot Count Units Buildable Non-Ag Acres Topography Street Access Utilities Amenities LAND QUALITY FLOOD ZONE Method Base Lot Value Factor Value Adjustments Lot Value	

\\tsclient\C\Users\Randy Necessary\Pictures\101_0930\IMG_0008. 9/30/2021

Residential Data	
Type	6 Mobile Home 70 x 14
Condition	3 - Average
Quality	3 - Average
Architecture	6 MS ADJ
Style	100% Single Wide
Exterior Wall	100% Frame, Plywood or Hardboard
Base/Total Area	980 / 980
Style	100% Single Wide
HVAC	100% Warmed & Cooled Air
Roof Cover	14 Metal, Ribbed
Area on Slab	0
Fixture/RghIn	/
Bed/F/H Bath	/ /
Basement Area	
Garage Type	
Remodel	
Year/Eff Age	1984 / 32

GRM Approach	
GRM Code	
Gross Rent	0.00
Indicated Value	

Multiple Regression	
MRA Code	
Adjusted R	
Indicated Value	

Direct Comparables	
Selection Model	1 Res
Adjustment Model	A2 AO Test
Comparables	
Indicated Value	

Cost Approach				Manual : 01/2025			
Base Cost	37.09	Total Misc Impr	+	32,411			
Roofing Adj	+ 2.92	Garage Cost	+				
Subfloor Adj	+ 0.00	Total RCN	=	86,585			
Heat/Cool Adj	+ 4.42	Depreciation (70%)	-	60,610			
Plumbing Adj	+ 10.85	Lump Sums	+	9,772			
Basement Adj	+ 0.00	RCNLD	=	35,747			
Adj Base Cost	= 55.28	Lot Value	+				
Total Area	x 980	Indicated Value	=	35,747			
Adjusted Cost	= 54,174	Value Per SqFt		36.48			

Value Reconciliation			
Selected Approach	Cost Approach		
Improvements	35,747		
Lot Value			
Indicated Value	35,747	36.48	Per SqFt
Agland Value			
Site Improvements			
Total Value	35,747	36.48	Total Value Per SqFt

Miscellaneous Improvements								
Code	Description	Sketch ID	Size	Year	Units	Unit Cost	Depr	Value
WODC	WOOD DECK - COVERED	136523	12x6		72	49.87	30%	2,513
EPSW	Enclosed Porch - Solid Wall	151788	24x24		576	39.82		22,936
LTP	Lean-To PORCH	151789	12x10		120	2.93		352
WODC	Wood Deck - Covered	151790	18x10		180	40.33		7,259
EPSW	Enclosed Porch - Solid Wall	151791	22x10		220	41.47		9,123



Rogers

Assessment Property Record Card for Tax Year 2026

Data provided by LISA DELOZIER County Assessor

Date 04/17/2026

Time 04:27:43

Page 5

Sketch Image

660018032

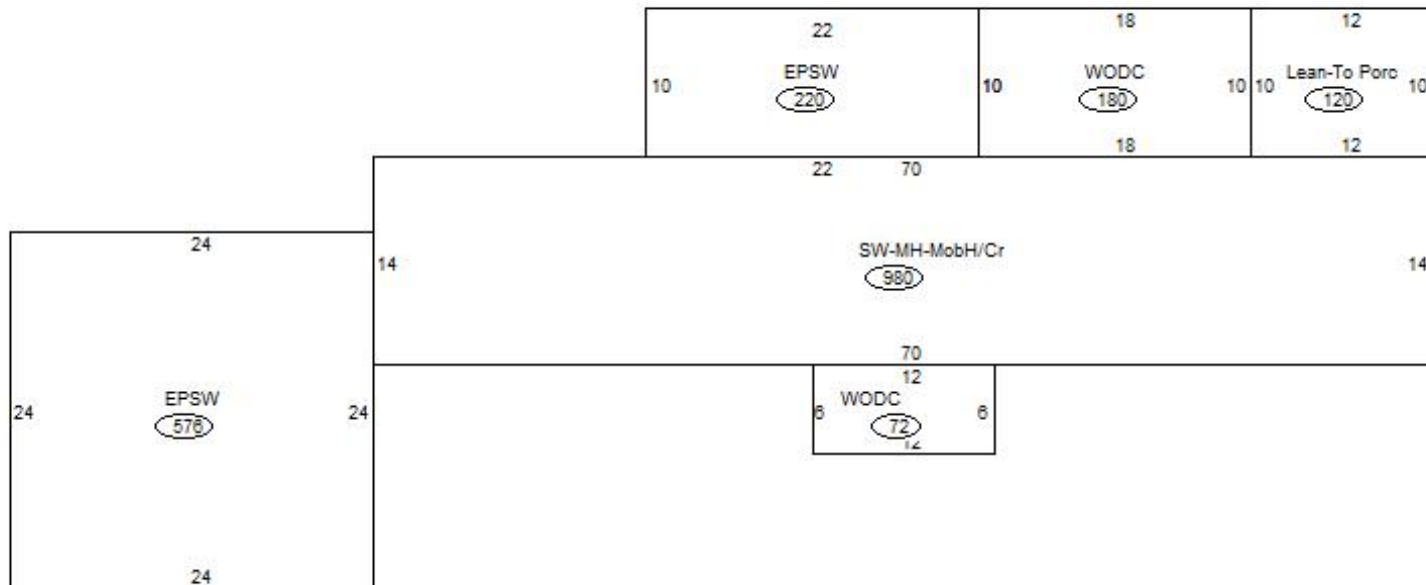

Sketch Vector Information

Sequence	Code	Type	Built Over	Scale	Section Label	Base Area	Multiplier	Total Area
1	R	13	Crawl	13	SW-MH-MobH/Cr	980	1.000	980
2	M	WODC		13	WODC	72	1.000	72
3	M	EPSW		13	EPSW	576	1.000	576
4	M	LTP		13	Lean-To Porc	120	1.000	120
5	M	WODC		13	WODC	180	1.000	180
6	M	EPSW		13	EPSW	220	1.000	220
Total Building Area						980		980