



# Rogers

## Assessment Property Record Card for Tax Year 2026

Data provided by LISA DELOZIER County Assessor

Date 04/18/2026  
Time 07:24:00  
Page 1

| Assessment Data  |                        |                        |          |             | Primary Image |               |            |             |           |  |                  |              |          |             |   |               |            |             |                |                        |                        |         |         |         |          |                  |                |                        |     |                      |                        |            |          |         |                |                        |                |         |               |        |          |      |                |                        |      |                |   |                     |          |      |                |                        |        |          |   |        |          |      |                |                        |    |         |   |        |          |      |                |                        |    |         |   |        |          |      |                |                        |    |         |   |        |          |      |                |                        |    |         |      |        |          |      |                |                  |    |         |      |        |          |      |                |                  |    |         |      |        |          |      |                |                  |    |         |      |        |          |      |                |                  |    |         |      |        |          |
|--|------------------------|------------------------|----------|-------------|---------------|---------------|------------|-------------|-----------|--|------------------|--------------|----------|-------------|---|---------------|------------|-------------|----------------|------------------------|------------------------|---------|---------|---------|----------|------------------|----------------|------------------------|-----|----------------------|------------------------|------------|----------|---------|----------------|------------------------|----------------|---------|---------------|--------|----------|------|----------------|------------------------|------|----------------|---|---------------------|----------|------|----------------|------------------------|--------|----------|---|--------|----------|------|----------------|------------------------|----|---------|---|--------|----------|------|----------------|------------------------|----|---------|---|--------|----------|------|----------------|------------------------|----|---------|---|--------|----------|------|----------------|------------------------|----|---------|------|--------|----------|------|----------------|------------------|----|---------|------|--------|----------|------|----------------|------------------|----|---------|------|--------|----------|------|----------------|------------------|----|---------|------|--------|----------|------|----------------|------------------|----|---------|------|--------|----------|
| <b>Account</b> 660090351<br><b>Parcel ID</b> 000000-00-0-00856-003-0005<br><b>Cadastral ID</b> 22-22-14-09250<br><b>Property Type</b> REAL - Real Property<br><b>Property Class</b> RRP VI Area 2<br><b>Tax Area</b> 27 - COLLINSVILLE/COLL FIRE<br><b>Name ID</b> 322125<br>BERG, DAVID & SHELLY &<br>MAX & CAROL BOOZE<br><br>14994 N 147TH E AVE<br>COLLINSVILLE OK 74021-0000<br><br><b>Parcel Location</b><br><b>Situs</b> 14994 N 147TH E AVE<br><b>Subdivision</b> TYLER CROSSING<br><b>Lot/Block</b> 0005 / 0003 <b>Parcel Size</b> 1 - Lots<br><b>Sec/Twn/Rng</b> 22 / 22 / 14 / 5<br><b>Neighborhood</b> 1096 - R-V02-NW COLLINSVILLE<br><b>School District</b> S026 - COLLINSVILLE SCHOOLS  |                        |                        |          |             |               |               |            |             |           |  |                  |              |          |             |   |               |            |             |                |                        |                        |         |         |         |          |                  |                |                        |     |                      |                        |            |          |         |                |                        |                |         |               |        |          |      |                |                        |      |                |   |                     |          |      |                |                        |        |          |   |        |          |      |                |                        |    |         |   |        |          |      |                |                        |    |         |   |        |          |      |                |                        |    |         |   |        |          |      |                |                        |    |         |      |        |          |      |                |                  |    |         |      |        |          |      |                |                  |    |         |      |        |          |      |                |                  |    |         |      |        |          |      |                |                  |    |         |      |        |          |
| <b>Legal Description</b> Lot/Long: 36.37000602 -95.81003845<br>LOT 5 BLOCK 3 TYLER CROSSING  |                        |                        |          |             |               |               |            |             |           | <b>Building Permits</b><br><table border="1"> <thead> <tr> <th>Number</th> <th>Description</th> <th>Opened</th> <th>Closed</th> <th>Amount</th> </tr> </thead> <tbody> <tr> <td>R2011 01 3</td> <td>R12-NEW 3000 SQ FT SFR</td> <td>01/2011</td> <td>09/2011</td> <td>200,000</td> </tr> </tbody> </table> |                  |              |          |             | Number  | Description   | Opened     | Closed      | Amount         | R2011 01 3             | R12-NEW 3000 SQ FT SFR | 01/2011 | 09/2011 | 200,000 |          |                  |                |                        |     |                      |                        |            |          |         |                |                        |                |         |               |        |          |      |                |                        |      |                |   |                     |          |      |                |                        |        |          |   |        |          |      |                |                        |    |         |   |        |          |      |                |                        |    |         |   |        |          |      |                |                        |    |         |   |        |          |      |                |                        |    |         |      |        |          |      |                |                  |    |         |      |        |          |      |                |                  |    |         |      |        |          |      |                |                  |    |         |      |        |          |      |                |                  |    |         |      |        |          |
| Number   | Description            | Opened                 | Closed   | Amount      |               |               |            |             |           |  |                  |              |          |             |   |               |            |             |                |                        |                        |         |         |         |          |                  |                |                        |     |                      |                        |            |          |         |                |                        |                |         |               |        |          |      |                |                        |      |                |   |                     |          |      |                |                        |        |          |   |        |          |      |                |                        |    |         |   |        |          |      |                |                        |    |         |   |        |          |      |                |                        |    |         |   |        |          |      |                |                        |    |         |      |        |          |      |                |                  |    |         |      |        |          |      |                |                  |    |         |      |        |          |      |                |                  |    |         |      |        |          |      |                |                  |    |         |      |        |          |
| R2011 01 3   | R12-NEW 3000 SQ FT SFR | 01/2011                | 09/2011  | 200,000     |               |               |            |             |           |  |                  |              |          |             |   |               |            |             |                |                        |                        |         |         |         |          |                  |                |                        |     |                      |                        |            |          |         |                |                        |                |         |               |        |          |      |                |                        |      |                |   |                     |          |      |                |                        |        |          |   |        |          |      |                |                        |    |         |   |        |          |      |                |                        |    |         |   |        |          |      |                |                        |    |         |   |        |          |      |                |                        |    |         |      |        |          |      |                |                  |    |         |      |        |          |      |                |                  |    |         |      |        |          |      |                |                  |    |         |      |        |          |      |                |                  |    |         |      |        |          |
| <b>Exemptions</b><br><table border="1"> <thead> <tr> <th>Code</th> <th>Type</th> <th>Active</th> <th>Maximum</th> <th>Exemption</th> </tr> </thead> <tbody> <tr> <td>H</td> <td>Homestead</td> <td>No</td> <td>1,000</td> <td></td> </tr> </tbody> </table>  |                        |                        |          |             | Code          | Type          | Active     | Maximum     | Exemption | H  | Homestead        | No           | 1,000    |             | <b>Sale History</b><br><table border="1"> <thead> <tr> <th>Bk/Pg</th> <th>Grantor</th> <th>Date</th> <th>Price</th> <th>Code</th> </tr> </thead> <tbody> <tr> <td>2651/381</td> <td>CAUSEY, JOHN S &amp;</td> <td>07/24/2017</td> <td>395,000</td> <td>YES</td> </tr> <tr> <td>2186/708</td> <td>SMALYGO PROPERTIES INC</td> <td>08/05/2011</td> <td>352,000</td> <td>YES</td> </tr> <tr> <td>2149/671</td> <td>TYLER CROSSING DEV LLC</td> <td>12/20/2010</td> <td>0</td> <td>5</td> </tr> </tbody> </table> |               |            |             |                | Bk/Pg                  | Grantor                | Date    | Price   | Code    | 2651/381 | CAUSEY, JOHN S & | 07/24/2017     | 395,000                | YES | 2186/708             | SMALYGO PROPERTIES INC | 08/05/2011 | 352,000  | YES     | 2149/671       | TYLER CROSSING DEV LLC | 12/20/2010     | 0       | 5             |        |          |      |                |                        |      |                |   |                     |          |      |                |                        |        |          |   |        |          |      |                |                        |    |         |   |        |          |      |                |                        |    |         |   |        |          |      |                |                        |    |         |   |        |          |      |                |                        |    |         |      |        |          |      |                |                  |    |         |      |        |          |      |                |                  |    |         |      |        |          |      |                |                  |    |         |      |        |          |      |                |                  |    |         |      |        |          |
| Code   | Type                   | Active                 | Maximum  | Exemption   |               |               |            |             |           |  |                  |              |          |             |   |               |            |             |                |                        |                        |         |         |         |          |                  |                |                        |     |                      |                        |            |          |         |                |                        |                |         |               |        |          |      |                |                        |      |                |   |                     |          |      |                |                        |        |          |   |        |          |      |                |                        |    |         |   |        |          |      |                |                        |    |         |   |        |          |      |                |                        |    |         |   |        |          |      |                |                        |    |         |      |        |          |      |                |                  |    |         |      |        |          |      |                |                  |    |         |      |        |          |      |                |                  |    |         |      |        |          |      |                |                  |    |         |      |        |          |
| H  | Homestead              | No                     | 1,000    |             |               |               |            |             |           |  |                  |              |          |             |   |               |            |             |                |                        |                        |         |         |         |          |                  |                |                        |     |                      |                        |            |          |         |                |                        |                |         |               |        |          |      |                |                        |      |                |   |                     |          |      |                |                        |        |          |   |        |          |      |                |                        |    |         |   |        |          |      |                |                        |    |         |   |        |          |      |                |                        |    |         |   |        |          |      |                |                        |    |         |      |        |          |      |                |                  |    |         |      |        |          |      |                |                  |    |         |      |        |          |      |                |                  |    |         |      |        |          |      |                |                  |    |         |      |        |          |
| Bk/Pg  | Grantor                | Date                   | Price    | Code        |               |               |            |             |           |  |                  |              |          |             |   |               |            |             |                |                        |                        |         |         |         |          |                  |                |                        |     |                      |                        |            |          |         |                |                        |                |         |               |        |          |      |                |                        |      |                |   |                     |          |      |                |                        |        |          |   |        |          |      |                |                        |    |         |   |        |          |      |                |                        |    |         |   |        |          |      |                |                        |    |         |   |        |          |      |                |                        |    |         |      |        |          |      |                |                  |    |         |      |        |          |      |                |                  |    |         |      |        |          |      |                |                  |    |         |      |        |          |      |                |                  |    |         |      |        |          |
| 2651/381   | CAUSEY, JOHN S &       | 07/24/2017             | 395,000  | YES         |               |               |            |             |           |  |                  |              |          |             |   |               |            |             |                |                        |                        |         |         |         |          |                  |                |                        |     |                      |                        |            |          |         |                |                        |                |         |               |        |          |      |                |                        |      |                |   |                     |          |      |                |                        |        |          |   |        |          |      |                |                        |    |         |   |        |          |      |                |                        |    |         |   |        |          |      |                |                        |    |         |   |        |          |      |                |                        |    |         |      |        |          |      |                |                  |    |         |      |        |          |      |                |                  |    |         |      |        |          |      |                |                  |    |         |      |        |          |      |                |                  |    |         |      |        |          |
| 2186/708   | SMALYGO PROPERTIES INC | 08/05/2011             | 352,000  | YES         |               |               |            |             |           |  |                  |              |          |             |   |               |            |             |                |                        |                        |         |         |         |          |                  |                |                        |     |                      |                        |            |          |         |                |                        |                |         |               |        |          |      |                |                        |      |                |   |                     |          |      |                |                        |        |          |   |        |          |      |                |                        |    |         |   |        |          |      |                |                        |    |         |   |        |          |      |                |                        |    |         |   |        |          |      |                |                        |    |         |      |        |          |      |                |                  |    |         |      |        |          |      |                |                  |    |         |      |        |          |      |                |                  |    |         |      |        |          |      |                |                  |    |         |      |        |          |
| 2149/671   | TYLER CROSSING DEV LLC | 12/20/2010             | 0        | 5           |               |               |            |             |           |  |                  |              |          |             |   |               |            |             |                |                        |                        |         |         |         |          |                  |                |                        |     |                      |                        |            |          |         |                |                        |                |         |               |        |          |      |                |                        |      |                |   |                     |          |      |                |                        |        |          |   |        |          |      |                |                        |    |         |   |        |          |      |                |                        |    |         |   |        |          |      |                |                        |    |         |   |        |          |      |                |                        |    |         |      |        |          |      |                |                  |    |         |      |        |          |      |                |                  |    |         |      |        |          |      |                |                  |    |         |      |        |          |      |                |                  |    |         |      |        |          |
| <b>Parcel Valuation</b><br><table border="1"> <thead> <tr> <th>Source</th> <th>REAL</th> <th>Fair Cash</th> <th>Capped</th> <th>Asmnt Level</th> <th>Assessed</th> <th>Levy Rate</th> <th>102.120</th> <th>Current Tax</th> </tr> </thead> <tbody> <tr> <td>Remove Cap</td> <td>2018</td> <td>Land Value 49,883</td> <td>49,883</td> <td>11%</td> <td>5,487</td> <td>Assessed</td> <td>57,824</td> <td>5,904.99</td> </tr> <tr> <td>Year Frozen</td> <td>0</td> <td>Improvements 475,791</td> <td>475,791</td> <td></td> <td>52,337</td> <td>Penalty</td> <td>0</td> <td></td> </tr> <tr> <td>Uncapped Value</td> <td>0</td> <td>Mobile Home 0</td> <td>0</td> <td></td> <td>0</td> <td>Exemption</td> <td>0</td> <td>0.00</td> </tr> <tr> <td>TIF Project ID</td> <td>0</td> <td>Total Value 525,674</td> <td>525,674</td> <td></td> <td>57,824</td> <td>Total Taxable</td> <td>57,824</td> <td>5,905.00</td> </tr> </tbody> </table>   |                        |                        |          |             |               |               |            |             |           | Source   | REAL             | Fair Cash    | Capped   | Asmnt Level | Assessed  | Levy Rate     | 102.120    | Current Tax | Remove Cap     | 2018                   | Land Value 49,883      | 49,883  | 11%     | 5,487   | Assessed | 57,824           | 5,904.99       | Year Frozen            | 0   | Improvements 475,791 | 475,791                |            | 52,337   | Penalty | 0              |                        | Uncapped Value | 0       | Mobile Home 0 | 0      |          | 0    | Exemption      | 0                      | 0.00 | TIF Project ID | 0 | Total Value 525,674 | 525,674  |      | 57,824         | Total Taxable          | 57,824 | 5,905.00 |   |        |          |      |                |                        |    |         |   |        |          |      |                |                        |    |         |   |        |          |      |                |                        |    |         |   |        |          |      |                |                        |    |         |      |        |          |      |                |                  |    |         |      |        |          |      |                |                  |    |         |      |        |          |      |                |                  |    |         |      |        |          |      |                |                  |    |         |      |        |          |
| Source   | REAL                   | Fair Cash              | Capped   | Asmnt Level | Assessed      | Levy Rate     | 102.120    | Current Tax |           |  |                  |              |          |             |   |               |            |             |                |                        |                        |         |         |         |          |                  |                |                        |     |                      |                        |            |          |         |                |                        |                |         |               |        |          |      |                |                        |      |                |   |                     |          |      |                |                        |        |          |   |        |          |      |                |                        |    |         |   |        |          |      |                |                        |    |         |   |        |          |      |                |                        |    |         |   |        |          |      |                |                        |    |         |      |        |          |      |                |                  |    |         |      |        |          |      |                |                  |    |         |      |        |          |      |                |                  |    |         |      |        |          |      |                |                  |    |         |      |        |          |
| Remove Cap   | 2018                   | Land Value 49,883      | 49,883   | 11%         | 5,487         | Assessed      | 57,824     | 5,904.99    |           |  |                  |              |          |             |   |               |            |             |                |                        |                        |         |         |         |          |                  |                |                        |     |                      |                        |            |          |         |                |                        |                |         |               |        |          |      |                |                        |      |                |   |                     |          |      |                |                        |        |          |   |        |          |      |                |                        |    |         |   |        |          |      |                |                        |    |         |   |        |          |      |                |                        |    |         |   |        |          |      |                |                        |    |         |      |        |          |      |                |                  |    |         |      |        |          |      |                |                  |    |         |      |        |          |      |                |                  |    |         |      |        |          |      |                |                  |    |         |      |        |          |
| Year Frozen  | 0                      | Improvements 475,791   | 475,791  |             | 52,337        | Penalty       | 0          |             |           |  |                  |              |          |             |   |               |            |             |                |                        |                        |         |         |         |          |                  |                |                        |     |                      |                        |            |          |         |                |                        |                |         |               |        |          |      |                |                        |      |                |   |                     |          |      |                |                        |        |          |   |        |          |      |                |                        |    |         |   |        |          |      |                |                        |    |         |   |        |          |      |                |                        |    |         |   |        |          |      |                |                        |    |         |      |        |          |      |                |                  |    |         |      |        |          |      |                |                  |    |         |      |        |          |      |                |                  |    |         |      |        |          |      |                |                  |    |         |      |        |          |
| Uncapped Value   | 0                      | Mobile Home 0          | 0        |             | 0             | Exemption     | 0          | 0.00        |           |  |                  |              |          |             |   |               |            |             |                |                        |                        |         |         |         |          |                  |                |                        |     |                      |                        |            |          |         |                |                        |                |         |               |        |          |      |                |                        |      |                |   |                     |          |      |                |                        |        |          |   |        |          |      |                |                        |    |         |   |        |          |      |                |                        |    |         |   |        |          |      |                |                        |    |         |   |        |          |      |                |                        |    |         |      |        |          |      |                |                  |    |         |      |        |          |      |                |                  |    |         |      |        |          |      |                |                  |    |         |      |        |          |      |                |                  |    |         |      |        |          |
| TIF Project ID   | 0                      | Total Value 525,674    | 525,674  |             | 57,824        | Total Taxable | 57,824     | 5,905.00    |           |  |                  |              |          |             |   |               |            |             |                |                        |                        |         |         |         |          |                  |                |                        |     |                      |                        |            |          |         |                |                        |                |         |               |        |          |      |                |                        |      |                |   |                     |          |      |                |                        |        |          |   |        |          |      |                |                        |    |         |   |        |          |      |                |                        |    |         |   |        |          |      |                |                        |    |         |   |        |          |      |                |                        |    |         |      |        |          |      |                |                  |    |         |      |        |          |      |                |                  |    |         |      |        |          |      |                |                  |    |         |      |        |          |      |                |                  |    |         |      |        |          |
| <b>Assessment History</b><br><table border="1"> <thead> <tr> <th>Tax Year</th> <th>Statement Number</th> <th>Billed Owner</th> <th>Tax Area</th> <th>Total Value</th> <th>Exemptions</th> <th>Taxable Value</th> <th>Billed Tax</th> </tr> </thead> <tbody> <tr><td>2025</td><td>2025-660090351</td><td>BERG, DAVID &amp; SHELLY &amp;</td><td>27</td><td>503,847</td><td>0</td><td>55,423</td><td>5,660.00</td></tr> <tr><td>2024</td><td>2024-660090351</td><td>BERG, DAVID &amp; SHELLY &amp;</td><td>27</td><td>537,856</td><td>0</td><td>53,571</td><td>5,368.00</td></tr> <tr><td>2023</td><td>2023-660090351</td><td>BERG, DAVID &amp; SHELLY &amp;</td><td>27</td><td>477,492</td><td>0</td><td>51,020</td><td>5,018.00</td></tr> <tr><td>2022</td><td>2022-660090351</td><td>BERG, DAVID &amp; SHELLY &amp;</td><td>27</td><td>482,364</td><td>0</td><td>48,591</td><td>4,747.00</td></tr> <tr><td>2021</td><td>2021-660090351</td><td>BERG, DAVID &amp; SHELLY &amp;</td><td>27</td><td>420,700</td><td>0</td><td>46,277</td><td>4,591.00</td></tr> <tr><td>2020</td><td>2020-660090351</td><td>BERG, DAVID &amp; SHELLY &amp;</td><td>27</td><td>413,639</td><td>0</td><td>45,500</td><td>4,525.00</td></tr> <tr><td>2019</td><td>2019-660090351</td><td>BERG, DAVID &amp; SHELLY &amp;</td><td>27</td><td>396,517</td><td>0</td><td>43,617</td><td>4,289.00</td></tr> <tr><td>2018</td><td>2018-660090351</td><td>BERG, DAVID &amp; SHELLY &amp;</td><td>27</td><td>393,816</td><td>0</td><td>43,320</td><td>4,307.00</td></tr> <tr><td>2017</td><td>2017-660090351</td><td>BERG, DAVID &amp; SHELLY &amp;</td><td>27</td><td>366,680</td><td>1000</td><td>39,335</td><td>3,849.00</td></tr> <tr><td>2016</td><td>2016-660090351</td><td>CAUSEY, JOHN S &amp;</td><td>27</td><td>356,000</td><td>1000</td><td>38,160</td><td>3,640.00</td></tr> <tr><td>2015</td><td>2015-660090351</td><td>CAUSEY, JOHN S &amp;</td><td>27</td><td>356,000</td><td>1000</td><td>38,160</td><td>3,684.00</td></tr> <tr><td>2014</td><td>2014-660090351</td><td>CAUSEY, JOHN S &amp;</td><td>27</td><td>356,000</td><td>1000</td><td>38,160</td><td>3,573.00</td></tr> <tr><td>2013</td><td>2013-660090351</td><td>CAUSEY, JOHN S &amp;</td><td>27</td><td>356,000</td><td>1000</td><td>38,160</td><td>3,563.00</td></tr> </tbody> </table> |                        |                        |          |             |               |               |            |             |           | Tax Year   | Statement Number | Billed Owner | Tax Area | Total Value | Exemptions  | Taxable Value | Billed Tax | 2025        | 2025-660090351 | BERG, DAVID & SHELLY & | 27                     | 503,847 | 0       | 55,423  | 5,660.00 | 2024             | 2024-660090351 | BERG, DAVID & SHELLY & | 27  | 537,856              | 0                      | 53,571     | 5,368.00 | 2023    | 2023-660090351 | BERG, DAVID & SHELLY & | 27             | 477,492 | 0             | 51,020 | 5,018.00 | 2022 | 2022-660090351 | BERG, DAVID & SHELLY & | 27   | 482,364        | 0 | 48,591              | 4,747.00 | 2021 | 2021-660090351 | BERG, DAVID & SHELLY & | 27     | 420,700  | 0 | 46,277 | 4,591.00 | 2020 | 2020-660090351 | BERG, DAVID & SHELLY & | 27 | 413,639 | 0 | 45,500 | 4,525.00 | 2019 | 2019-660090351 | BERG, DAVID & SHELLY & | 27 | 396,517 | 0 | 43,617 | 4,289.00 | 2018 | 2018-660090351 | BERG, DAVID & SHELLY & | 27 | 393,816 | 0 | 43,320 | 4,307.00 | 2017 | 2017-660090351 | BERG, DAVID & SHELLY & | 27 | 366,680 | 1000 | 39,335 | 3,849.00 | 2016 | 2016-660090351 | CAUSEY, JOHN S & | 27 | 356,000 | 1000 | 38,160 | 3,640.00 | 2015 | 2015-660090351 | CAUSEY, JOHN S & | 27 | 356,000 | 1000 | 38,160 | 3,684.00 | 2014 | 2014-660090351 | CAUSEY, JOHN S & | 27 | 356,000 | 1000 | 38,160 | 3,573.00 | 2013 | 2013-660090351 | CAUSEY, JOHN S & | 27 | 356,000 | 1000 | 38,160 | 3,563.00 |
| Tax Year   | Statement Number       | Billed Owner           | Tax Area | Total Value | Exemptions    | Taxable Value | Billed Tax |             |           |  |                  |              |          |             |   |               |            |             |                |                        |                        |         |         |         |          |                  |                |                        |     |                      |                        |            |          |         |                |                        |                |         |               |        |          |      |                |                        |      |                |   |                     |          |      |                |                        |        |          |   |        |          |      |                |                        |    |         |   |        |          |      |                |                        |    |         |   |        |          |      |                |                        |    |         |   |        |          |      |                |                        |    |         |      |        |          |      |                |                  |    |         |      |        |          |      |                |                  |    |         |      |        |          |      |                |                  |    |         |      |        |          |      |                |                  |    |         |      |        |          |
| 2025   | 2025-660090351         | BERG, DAVID & SHELLY & | 27       | 503,847     | 0             | 55,423        | 5,660.00   |             |           |  |                  |              |          |             |   |               |            |             |                |                        |                        |         |         |         |          |                  |                |                        |     |                      |                        |            |          |         |                |                        |                |         |               |        |          |      |                |                        |      |                |   |                     |          |      |                |                        |        |          |   |        |          |      |                |                        |    |         |   |        |          |      |                |                        |    |         |   |        |          |      |                |                        |    |         |   |        |          |      |                |                        |    |         |      |        |          |      |                |                  |    |         |      |        |          |      |                |                  |    |         |      |        |          |      |                |                  |    |         |      |        |          |      |                |                  |    |         |      |        |          |
| 2024   | 2024-660090351         | BERG, DAVID & SHELLY & | 27       | 537,856     | 0             | 53,571        | 5,368.00   |             |           |  |                  |              |          |             |   |               |            |             |                |                        |                        |         |         |         |          |                  |                |                        |     |                      |                        |            |          |         |                |                        |                |         |               |        |          |      |                |                        |      |                |   |                     |          |      |                |                        |        |          |   |        |          |      |                |                        |    |         |   |        |          |      |                |                        |    |         |   |        |          |      |                |                        |    |         |   |        |          |      |                |                        |    |         |      |        |          |      |                |                  |    |         |      |        |          |      |                |                  |    |         |      |        |          |      |                |                  |    |         |      |        |          |      |                |                  |    |         |      |        |          |
| 2023   | 2023-660090351         | BERG, DAVID & SHELLY & | 27       | 477,492     | 0             | 51,020        | 5,018.00   |             |           |  |                  |              |          |             |   |               |            |             |                |                        |                        |         |         |         |          |                  |                |                        |     |                      |                        |            |          |         |                |                        |                |         |               |        |          |      |                |                        |      |                |   |                     |          |      |                |                        |        |          |   |        |          |      |                |                        |    |         |   |        |          |      |                |                        |    |         |   |        |          |      |                |                        |    |         |   |        |          |      |                |                        |    |         |      |        |          |      |                |                  |    |         |      |        |          |      |                |                  |    |         |      |        |          |      |                |                  |    |         |      |        |          |      |                |                  |    |         |      |        |          |
| 2022   | 2022-660090351         | BERG, DAVID & SHELLY & | 27       | 482,364     | 0             | 48,591        | 4,747.00   |             |           |  |                  |              |          |             |   |               |            |             |                |                        |                        |         |         |         |          |                  |                |                        |     |                      |                        |            |          |         |                |                        |                |         |               |        |          |      |                |                        |      |                |   |                     |          |      |                |                        |        |          |   |        |          |      |                |                        |    |         |   |        |          |      |                |                        |    |         |   |        |          |      |                |                        |    |         |   |        |          |      |                |                        |    |         |      |        |          |      |                |                  |    |         |      |        |          |      |                |                  |    |         |      |        |          |      |                |                  |    |         |      |        |          |      |                |                  |    |         |      |        |          |
| 2021   | 2021-660090351         | BERG, DAVID & SHELLY & | 27       | 420,700     | 0             | 46,277        | 4,591.00   |             |           |  |                  |              |          |             |   |               |            |             |                |                        |                        |         |         |         |          |                  |                |                        |     |                      |                        |            |          |         |                |                        |                |         |               |        |          |      |                |                        |      |                |   |                     |          |      |                |                        |        |          |   |        |          |      |                |                        |    |         |   |        |          |      |                |                        |    |         |   |        |          |      |                |                        |    |         |   |        |          |      |                |                        |    |         |      |        |          |      |                |                  |    |         |      |        |          |      |                |                  |    |         |      |        |          |      |                |                  |    |         |      |        |          |      |                |                  |    |         |      |        |          |
| 2020   | 2020-660090351         | BERG, DAVID & SHELLY & | 27       | 413,639     | 0             | 45,500        | 4,525.00   |             |           |  |                  |              |          |             |   |               |            |             |                |                        |                        |         |         |         |          |                  |                |                        |     |                      |                        |            |          |         |                |                        |                |         |               |        |          |      |                |                        |      |                |   |                     |          |      |                |                        |        |          |   |        |          |      |                |                        |    |         |   |        |          |      |                |                        |    |         |   |        |          |      |                |                        |    |         |   |        |          |      |                |                        |    |         |      |        |          |      |                |                  |    |         |      |        |          |      |                |                  |    |         |      |        |          |      |                |                  |    |         |      |        |          |      |                |                  |    |         |      |        |          |
| 2019   | 2019-660090351         | BERG, DAVID & SHELLY & | 27       | 396,517     | 0             | 43,617        | 4,289.00   |             |           |  |                  |              |          |             |   |               |            |             |                |                        |                        |         |         |         |          |                  |                |                        |     |                      |                        |            |          |         |                |                        |                |         |               |        |          |      |                |                        |      |                |   |                     |          |      |                |                        |        |          |   |        |          |      |                |                        |    |         |   |        |          |      |                |                        |    |         |   |        |          |      |                |                        |    |         |   |        |          |      |                |                        |    |         |      |        |          |      |                |                  |    |         |      |        |          |      |                |                  |    |         |      |        |          |      |                |                  |    |         |      |        |          |      |                |                  |    |         |      |        |          |
| 2018   | 2018-660090351         | BERG, DAVID & SHELLY & | 27       | 393,816     | 0             | 43,320        | 4,307.00   |             |           |  |                  |              |          |             |   |               |            |             |                |                        |                        |         |         |         |          |                  |                |                        |     |                      |                        |            |          |         |                |                        |                |         |               |        |          |      |                |                        |      |                |   |                     |          |      |                |                        |        |          |   |        |          |      |                |                        |    |         |   |        |          |      |                |                        |    |         |   |        |          |      |                |                        |    |         |   |        |          |      |                |                        |    |         |      |        |          |      |                |                  |    |         |      |        |          |      |                |                  |    |         |      |        |          |      |                |                  |    |         |      |        |          |      |                |                  |    |         |      |        |          |
| 2017   | 2017-660090351         | BERG, DAVID & SHELLY & | 27       | 366,680     | 1000          | 39,335        | 3,849.00   |             |           |  |                  |              |          |             |   |               |            |             |                |                        |                        |         |         |         |          |                  |                |                        |     |                      |                        |            |          |         |                |                        |                |         |               |        |          |      |                |                        |      |                |   |                     |          |      |                |                        |        |          |   |        |          |      |                |                        |    |         |   |        |          |      |                |                        |    |         |   |        |          |      |                |                        |    |         |   |        |          |      |                |                        |    |         |      |        |          |      |                |                  |    |         |      |        |          |      |                |                  |    |         |      |        |          |      |                |                  |    |         |      |        |          |      |                |                  |    |         |      |        |          |
| 2016   | 2016-660090351         | CAUSEY, JOHN S &       | 27       | 356,000     | 1000          | 38,160        | 3,640.00   |             |           |  |                  |              |          |             |   |               |            |             |                |                        |                        |         |         |         |          |                  |                |                        |     |                      |                        |            |          |         |                |                        |                |         |               |        |          |      |                |                        |      |                |   |                     |          |      |                |                        |        |          |   |        |          |      |                |                        |    |         |   |        |          |      |                |                        |    |         |   |        |          |      |                |                        |    |         |   |        |          |      |                |                        |    |         |      |        |          |      |                |                  |    |         |      |        |          |      |                |                  |    |         |      |        |          |      |                |                  |    |         |      |        |          |      |                |                  |    |         |      |        |          |
| 2015   | 2015-660090351         | CAUSEY, JOHN S &       | 27       | 356,000     | 1000          | 38,160        | 3,684.00   |             |           |  |                  |              |          |             |   |               |            |             |                |                        |                        |         |         |         |          |                  |                |                        |     |                      |                        |            |          |         |                |                        |                |         |               |        |          |      |                |                        |      |                |   |                     |          |      |                |                        |        |          |   |        |          |      |                |                        |    |         |   |        |          |      |                |                        |    |         |   |        |          |      |                |                        |    |         |   |        |          |      |                |                        |    |         |      |        |          |      |                |                  |    |         |      |        |          |      |                |                  |    |         |      |        |          |      |                |                  |    |         |      |        |          |      |                |                  |    |         |      |        |          |
| 2014   | 2014-660090351         | CAUSEY, JOHN S &       | 27       | 356,000     | 1000          | 38,160        | 3,573.00   |             |           |  |                  |              |          |             |   |               |            |             |                |                        |                        |         |         |         |          |                  |                |                        |     |                      |                        |            |          |         |                |                        |                |         |               |        |          |      |                |                        |      |                |   |                     |          |      |                |                        |        |          |   |        |          |      |                |                        |    |         |   |        |          |      |                |                        |    |         |   |        |          |      |                |                        |    |         |   |        |          |      |                |                        |    |         |      |        |          |      |                |                  |    |         |      |        |          |      |                |                  |    |         |      |        |          |      |                |                  |    |         |      |        |          |      |                |                  |    |         |      |        |          |
| 2013   | 2013-660090351         | CAUSEY, JOHN S &       | 27       | 356,000     | 1000          | 38,160        | 3,563.00   |             |           |  |                  |              |          |             |   |               |            |             |                |                        |                        |         |         |         |          |                  |                |                        |     |                      |                        |            |          |         |                |                        |                |         |               |        |          |      |                |                        |      |                |   |                     |          |      |                |                        |        |          |   |        |          |      |                |                        |    |         |   |        |          |      |                |                        |    |         |   |        |          |      |                |                        |    |         |   |        |          |      |                |                        |    |         |      |        |          |      |                |                  |    |         |      |        |          |      |                |                  |    |         |      |        |          |      |                |                  |    |         |      |        |          |      |                |                  |    |         |      |        |          |



# Rogers

## Assessment Property Record Card for Tax Year 2026

Data provided by LISA DELOZIER County Assessor

Date 04/18/2026  
Time 07:24:00  
Page 2

| Lot Data  | Square-Foot - NBHD 1096 #1 | Primary Image  |
|---|----------------------------|--|
| <b>Lot Size</b><br><b>Lot Count</b><br><b>Units Buildable</b> 1<br><b>Non-Ag Acres</b> 0.6027<br><b>Topography</b><br><b>Street Access</b><br><b>Utilities</b><br><b>Amenities</b> LAND QUALITY 0<br>0<br><b>Method</b> Square-Foot<br><b>Base Lot Value</b> 26,254.00 x 1.90 = 49,883<br><b>Factor Value</b><br><b>Adjustments</b> 1.0000<br><b>Lot Value</b> 49,883 |                            |  <p>08/26/2020 11:25</p> |

| Residential Data       |                           |
|------------------------|---------------------------|
| <b>Type</b>            | 1 Single Family Residence |
| <b>Condition</b>       | 3 - Average               |
| <b>Quality</b>         | 3.5 - Average             |
| <b>Architecture</b>    | TRAD TRADITIONAL          |
| <b>Style</b>           | 100% 1 1/2 Story Finished |
| <b>Exterior Wall</b>   | 100% Veneer, Masonry      |
| <b>Base/Total Area</b> | 2,276 / 3,565             |
| <b>Style</b>           | 100% 1 1/2 Story Finished |
| <b>HVAC</b>            | 100% Warmed & Cooled Air  |
| <b>Roof Cover</b>      | 1 Composition Shingle     |
| <b>Area on Slab</b>    | 0                         |
| <b>Fixture/RghIn</b>   | 17 /                      |
| <b>Bed/F/H Bath</b>    | 4 / 3.0 /                 |
| <b>Basement Area</b>   | 2,276 Total               |
| <b>Garage Type</b>     | 997 Built-In Garage       |
| <b>Remodel</b>         |                           |
| <b>Year/Eff Age</b>    | 2011 / 11                 |

\\tsclient\TCASEY\CASEY BOOTH VISUAL INSPECTION\2020-8- 8/26/2020

| GRM Approach           |      |
|------------------------|------|
| <b>GRM Code</b>        |      |
| <b>Gross Rent</b>      | 0.00 |
| <b>Indicated Value</b> |      |

| Multiple Regression    |         |        |          |
|------------------------|---------|--------|----------|
| <b>MRA Code</b>        | 1       | Test   |          |
| <b>Adusted R</b>       | 0.8445  |        |          |
| <b>Indicated Value</b> | 459,478 | 128.89 | Per SqFt |

| Direct Comparables      |         |                  |          |
|-------------------------|---------|------------------|----------|
| <b>Selection Model</b>  | A       | Adam Test        |          |
| <b>Adjustment Model</b> | 1       | 2022 Residential |          |
| <b>Comparables</b>      | 2       |                  |          |
| <b>Indicated Value</b>  | 465,700 |                  | Per SqFt |

| Value Reconciliation     |               |        |                      |
|--------------------------|---------------|--------|----------------------|
| <b>Selected Approach</b> | Cost Approach |        |                      |
| <b>Improvements</b>      | 475,791       |        |                      |
| <b>Lot Value</b>         | 49,883        |        |                      |
| <b>Indicated Value</b>   | 525,674       | 147.45 | Per SqFt             |
| <b>Agland Value</b>      |               |        |                      |
| <b>Site Improvements</b> |               |        |                      |
| <b>Total Value</b>       | 525,674       | 147.45 | Total Value Per SqFt |

| Cost Approach        |           |                            |           | Manual : 01/2025 |  |  |  |
|----------------------|-----------|----------------------------|-----------|------------------|--|--|--|
| <b>Base Cost</b>     | 95.38     | <b>Total Misc Impr</b>     | + 16,961  |                  |  |  |  |
| <b>Roofing Adj</b>   | + 3.34    | <b>Garage Cost</b>         | + 31,655  |                  |  |  |  |
| <b>Subfloor Adj</b>  | + 0.00    | <b>Total RCN</b>           | = 534,597 |                  |  |  |  |
| <b>Heat/Cool Adj</b> | + 14.47   | <b>Depreciation ( 11%)</b> | - 58,806  |                  |  |  |  |
| <b>Plumbing Adj</b>  | + 7.56    | <b>Lump Sums</b>           | + 0       |                  |  |  |  |
| <b>Basement Adj</b>  | + 15.57   | <b>RCNLD</b>               | = 475,791 |                  |  |  |  |
| <b>Adj Base Cost</b> | = 136.32  | <b>Lot Value</b>           | + 49,883  |                  |  |  |  |
| <b>Total Area</b>    | x 3,565   | <b>Indicated Value</b>     | = 525,674 |                  |  |  |  |
| <b>Adjusted Cost</b> | = 485,981 | <b>Value Per SqFt</b>      | 147.45    |                  |  |  |  |

| Miscellaneous Improvements |                                 |           |       |      |       |           |      |       |
|----------------------------|---------------------------------|-----------|-------|------|-------|-----------|------|-------|
| Code                       | Description                     | Sketch ID | Size  | Year | Units | Unit Cost | Depr | Value |
| FPR1                       | FIREPLACE - RESIDENTIAL 1 STORY | 0         |       | 1    | 1     | 6,429.63  |      | 6,430 |
| PRCH                       | SLAB PORCH - COVERED            | 110346    | 18x13 |      | 234   | 28.69     |      | 6,713 |
| PRCH                       | SLAB PORCH - COVERED            | 110347    | 69    |      | 69    | 29.31     |      | 2,022 |
| PATO                       | SLAB PORCH - OPEN               | 110348    | 18x8  |      | 144   | 12.47     |      | 1,796 |



# Rogers

## Assessment Property Record Card for Tax Year 2026

Data provided by LISA DELOZIER County Assessor

Date 04/18/2026

Time 07:24:00

Page 3

### Sketch Image

660090351

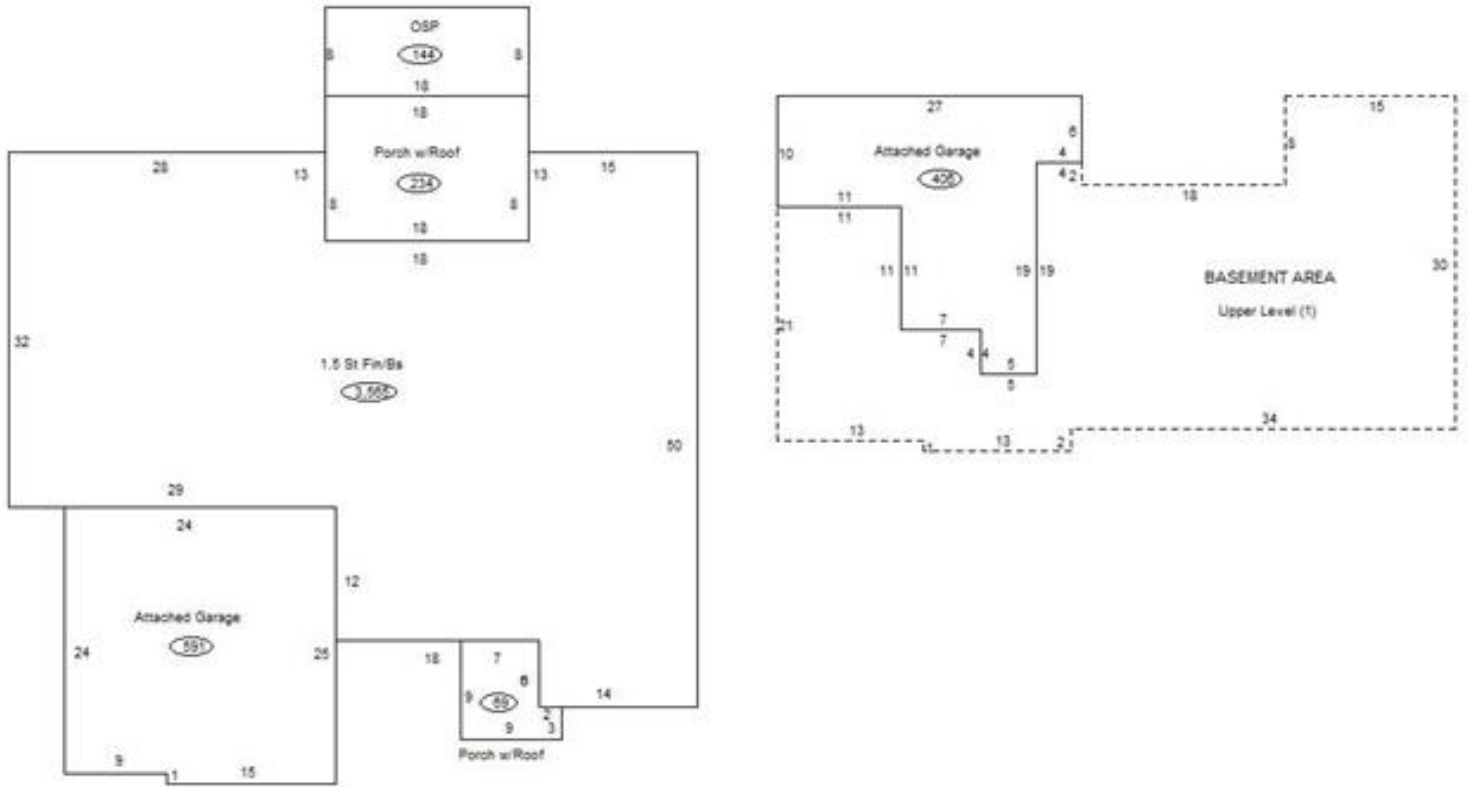

### Sketch Vector Information

| Sequence                   | Code | Type | Built Over | Scale | Section Label   | Base Area    | Multiplier | Total Area   |
|----------------------------|------|------|------------|-------|-----------------|--------------|------------|--------------|
| 1                          | R    | 5    | Basement   | 13    | 1.5 St Fin/Bs   | 2,276        | 1.566      | 3,565        |
| 2                          | G    | 1    |            | 13    | Attached Garage | 591          | 1.000      | 591          |
| 3                          | M    | PRCH |            | 13    | SLBC            | 234          | 1.000      | 234          |
| 4                          | M    | PRCH |            | 13    | SLBC            | 69           | 1.000      | 69           |
| 5                          | M    | PATO |            | 13    | Open Slab       | 144          | 1.000      | 144          |
| 6                          | U    | ^UL  |            | 13    | Upper Level (1) | 1,289        | 1.000      | 1,289        |
| 7                          | G    | 1    |            | 13    | Attached Garage | 406          | 1.000      | 406          |
| 8                          | N    | 0    |            | 13    | BASEMENT AREA   |              | 0.000      |              |
| <b>Total Building Area</b> |      |      |            |       |                 | <b>2,276</b> |            | <b>3,565</b> |