



Rogers

Assessment Property Record Card for Tax Year 2026

Data provided by LISA DELOZIER County Assessor

Date 04/18/2026
Time 08:37:44
Page 1

| Assessment Data | | | | | Primary Image | | | | | | | | | | | | | | | | | | | | | | | | | | | | | | | | | | | | | | | | | | | | | | | | | | | | | | | | | | | | | | | | | | | | | | | | | | | | | | | | | | | | | | | | | | | | | | | | | | | | | | | | | | | | |
|-----------------------------------------------------------------------------------------------------------------------------------------------------------------------------------------------------------------------------------------------------------------------------------------------------------------------------------------------------------------------------------------------------------------------------------------------------------------------------------------------------------------------------------------------------------------------------------------------------------------------------------------------------------------------------------------------------------------------------------------------------------------------------------------------------------------------------------------------------------------------------------------------------------------------------------------------------------------------------------------------------------------------------------------------------------------------------------------------------------------------------------------------------------------------------------------------------------------------------------------------------------------------------------------------------------------------------------------------------------------------------------------------------------------------------------------------------------------------------------------------------------------------------------------------------------------------------------------------------------------------------------------------------------------------------------------------------------------------------------------------------------------------------------------------------------------------------------------------------------------------------------------------------------------------------------------------------------------------------------------------------------------------------------------------------------|---------------------------|---------------------------|----------|-------------|------------------------------------------------------------------------------------------------------------------------------------------------------------------------------------------------------------------------------------------------------------------------------------------------------|---------------|------------|-------------|-----------|----------|------------------|--------------|----------|-------------|----------------------------------------------------------------------------------------------------------------------------------------------------------------------------------------------------------------------------------------------------------------------------------------------------------------------------------------------------------------------------------------------------------------------------------------------------------------------------------------------------|------------------------|------------|-------------|----------------|-----------------------|-------------------|---------|-------|--------|----------|------------------|----------------|-----------------------|-----|----------------------|---------------------------|------------|----------|---------|----------------|------------------------|----------------|---------|---------------|--------|----------|------|----------------|-----------------------|------|----------------|---|---------------------|----------|------|----------------|-----------------------|--------|----------|---|--------|----------|------|----------------|------------------|----|---------|---|--------|----------|------|----------------|------------------|----|---------|---|--------|----------|------|----------------|------------------|----|---------|---|--------|----------|------|----------------|------------------|----|---------|---|--------|----------|------|----------------|------------------|----|---------|---|--------|----------|------|----------------|---------------------------|----|--------|---|-------|--------|------|----------------|---------------------------|----|-------|---|-----|-------|
| Account 660095879 Parcel ID 000000-00-0-00457-004-00019 Cadastral ID 10-21-14-06340 Property Type REAL - Real Property Property Class URP VI Area 4 Tax Area 40 - OWASSO CITY Name ID 333725 BOYADJIAN, KHATCHIG N 14609 E 111TH PL N OWASSO OK 74055-0000 Parcel Location Situs 14609 E 111TH PL N Subdivision LAKE VALLEY V PHASE I Lot/Block 0019 / 0004 Parcel Size 1 - Lots Sec/Twn/Rng 10 / 21 / 14 / 5 Neighborhood 1059 - R-V04-SW OWASSO School District S021 - OWASSO SCHOOLS | | | | | | | | | | | | | | | | | | | | | | | | | | | | | | | | | | | | | | | | | | | | | | | | | | | | | | | | | | | | | | | | | | | | | | | | | | | | | | | | | | | | | | | | | | | | | | | | | | | | | | | | | | | | | | | | | |
| Legal Description Lat/Long: 36.31602497 -95.80987140 | | | | | | | | | | | | | | | | | | | | | | | | | | | | | | | | | | | | | | | | | | | | | | | | | | | | | | | | | | | | | | | | | | | | | | | | | | | | | | | | | | | | | | | | | | | | | | | | | | | | | | | | | | | | | | | | | |
| Legal Description LAKE VALLEY V - PHASE 1 BLOCK 4 LOT 19 | | | | | Building Permits <table border="1"> <thead> <tr> <th>Number</th> <th>Description</th> <th>Opened</th> <th>Closed</th> <th>Amount</th> </tr> </thead> <tbody> <tr> <td>14-020X</td> <td>R15-NEW 1755 SQ FT SFR</td> <td>03/2014</td> <td>09/2014</td> <td>118,525</td> </tr> </tbody> </table> | | | | | Number | Description | Opened | Closed | Amount | 14-020X | R15-NEW 1755 SQ FT SFR | 03/2014 | 09/2014 | 118,525 | | | | | | | | | | | | | | | | | | | | | | | | | | | | | | | | | | | | | | | | | | | | | | | | | | | | | | | | | | | | | | | | | | | | | | | | | | | | | | | | | | | | | | | | | | | | | | |
| Number | Description | Opened | Closed | Amount | | | | | | | | | | | | | | | | | | | | | | | | | | | | | | | | | | | | | | | | | | | | | | | | | | | | | | | | | | | | | | | | | | | | | | | | | | | | | | | | | | | | | | | | | | | | | | | | | | | | | | | | | | | | | |
| 14-020X | R15-NEW 1755 SQ FT SFR | 03/2014 | 09/2014 | 118,525 | | | | | | | | | | | | | | | | | | | | | | | | | | | | | | | | | | | | | | | | | | | | | | | | | | | | | | | | | | | | | | | | | | | | | | | | | | | | | | | | | | | | | | | | | | | | | | | | | | | | | | | | | | | | | |
| Exemptions <table border="1"> <thead> <tr> <th>Code</th> <th>Type</th> <th>Active</th> <th>Maximum</th> <th>Exemption</th> </tr> </thead> <tbody> <tr> <td></td> <td></td> <td></td> <td></td> <td></td> </tr> </tbody> </table> | | | | | Code | Type | Active | Maximum | Exemption | | | | | | Sale History <table border="1"> <thead> <tr> <th>Bk/Pg</th> <th>Grantor</th> <th>Date</th> <th>Price</th> <th>Code</th> </tr> </thead> <tbody> <tr> <td>/</td> <td>TALLMAN, VANCE E</td> <td>03/03/2021</td> <td>207,000</td> <td>YES</td> </tr> <tr> <td>2503/214</td> <td>SIMMONS HOMES RESIDENTIAL</td> <td>09/30/2015</td> <td>173,500</td> <td>YES</td> </tr> <tr> <td>2336/323</td> <td>LAKE VALLEY INVESTMENT</td> <td>06/19/2013</td> <td>0</td> <td>4</td> </tr> </tbody> </table> | | | | | Bk/Pg | Grantor | Date | Price | Code | / | TALLMAN, VANCE E | 03/03/2021 | 207,000 | YES | 2503/214 | SIMMONS HOMES RESIDENTIAL | 09/30/2015 | 173,500 | YES | 2336/323 | LAKE VALLEY INVESTMENT | 06/19/2013 | 0 | 4 | | | | | | | | | | | | | | | | | | | | | | | | | | | | | | | | | | | | | | | | | | | | | | | | | | | | | | | | | | | | | | | | | | | | | | | | | | |
| Code | Type | Active | Maximum | Exemption | | | | | | | | | | | | | | | | | | | | | | | | | | | | | | | | | | | | | | | | | | | | | | | | | | | | | | | | | | | | | | | | | | | | | | | | | | | | | | | | | | | | | | | | | | | | | | | | | | | | | | | | | | | | | |
| | | | | | | | | | | | | | | | | | | | | | | | | | | | | | | | | | | | | | | | | | | | | | | | | | | | | | | | | | | | | | | | | | | | | | | | | | | | | | | | | | | | | | | | | | | | | | | | | | | | | | | | | | | | | | | | | | |
| Bk/Pg | Grantor | Date | Price | Code | | | | | | | | | | | | | | | | | | | | | | | | | | | | | | | | | | | | | | | | | | | | | | | | | | | | | | | | | | | | | | | | | | | | | | | | | | | | | | | | | | | | | | | | | | | | | | | | | | | | | | | | | | | | | |
| / | TALLMAN, VANCE E | 03/03/2021 | 207,000 | YES | | | | | | | | | | | | | | | | | | | | | | | | | | | | | | | | | | | | | | | | | | | | | | | | | | | | | | | | | | | | | | | | | | | | | | | | | | | | | | | | | | | | | | | | | | | | | | | | | | | | | | | | | | | | | |
| 2503/214 | SIMMONS HOMES RESIDENTIAL | 09/30/2015 | 173,500 | YES | | | | | | | | | | | | | | | | | | | | | | | | | | | | | | | | | | | | | | | | | | | | | | | | | | | | | | | | | | | | | | | | | | | | | | | | | | | | | | | | | | | | | | | | | | | | | | | | | | | | | | | | | | | | | |
| 2336/323 | LAKE VALLEY INVESTMENT | 06/19/2013 | 0 | 4 | | | | | | | | | | | | | | | | | | | | | | | | | | | | | | | | | | | | | | | | | | | | | | | | | | | | | | | | | | | | | | | | | | | | | | | | | | | | | | | | | | | | | | | | | | | | | | | | | | | | | | | | | | | | | |
| Parcel Valuation <table border="1"> <thead> <tr> <th>Source</th> <th>REAL</th> <th>Fair Cash</th> <th>Capped</th> <th>Asmnt Level</th> <th>Assessed</th> <th>Levy Rate</th> <th>97.960</th> <th>Current Tax</th> </tr> </thead> <tbody> <tr> <td>Remove Cap</td> <td>2022</td> <td>Land Value 31,917</td> <td>31,917</td> <td>11%</td> <td>3,511</td> <td>Assessed</td> <td>26,359</td> <td>2,582.13</td> </tr> <tr> <td>Year Frozen</td> <td>0</td> <td>Improvements 214,451</td> <td>207,710</td> <td></td> <td>22,848</td> <td>Penalty</td> <td>0</td> <td></td> </tr> <tr> <td>Uncapped Value</td> <td>0</td> <td>Mobile Home 0</td> <td>0</td> <td></td> <td>0</td> <td>Exemption</td> <td>0</td> <td>0.00</td> </tr> <tr> <td>TIF Project ID</td> <td>0</td> <td>Total Value 246,368</td> <td>239,627</td> <td></td> <td>26,359</td> <td>Total Taxable</td> <td>26,359</td> <td>2,582.00</td> </tr> </tbody> </table> | | | | | | | | | | Source | REAL | Fair Cash | Capped | Asmnt Level | Assessed | Levy Rate | 97.960 | Current Tax | Remove Cap | 2022 | Land Value 31,917 | 31,917 | 11% | 3,511 | Assessed | 26,359 | 2,582.13 | Year Frozen | 0 | Improvements 214,451 | 207,710 | | 22,848 | Penalty | 0 | | Uncapped Value | 0 | Mobile Home 0 | 0 | | 0 | Exemption | 0 | 0.00 | TIF Project ID | 0 | Total Value 246,368 | 239,627 | | 26,359 | Total Taxable | 26,359 | 2,582.00 | | | | | | | | | | | | | | | | | | | | | | | | | | | | | | | | | | | | | | | | | | | | | | | | | | | | | | | | | | | |
| Source | REAL | Fair Cash | Capped | Asmnt Level | Assessed | Levy Rate | 97.960 | Current Tax | | | | | | | | | | | | | | | | | | | | | | | | | | | | | | | | | | | | | | | | | | | | | | | | | | | | | | | | | | | | | | | | | | | | | | | | | | | | | | | | | | | | | | | | | | | | | | | | | | | | | | | | | |
| Remove Cap | 2022 | Land Value 31,917 | 31,917 | 11% | 3,511 | Assessed | 26,359 | 2,582.13 | | | | | | | | | | | | | | | | | | | | | | | | | | | | | | | | | | | | | | | | | | | | | | | | | | | | | | | | | | | | | | | | | | | | | | | | | | | | | | | | | | | | | | | | | | | | | | | | | | | | | | | | | |
| Year Frozen | 0 | Improvements 214,451 | 207,710 | | 22,848 | Penalty | 0 | | | | | | | | | | | | | | | | | | | | | | | | | | | | | | | | | | | | | | | | | | | | | | | | | | | | | | | | | | | | | | | | | | | | | | | | | | | | | | | | | | | | | | | | | | | | | | | | | | | | | | | | | | |
| Uncapped Value | 0 | Mobile Home 0 | 0 | | 0 | Exemption | 0 | 0.00 | | | | | | | | | | | | | | | | | | | | | | | | | | | | | | | | | | | | | | | | | | | | | | | | | | | | | | | | | | | | | | | | | | | | | | | | | | | | | | | | | | | | | | | | | | | | | | | | | | | | | | | | | |
| TIF Project ID | 0 | Total Value 246,368 | 239,627 | | 26,359 | Total Taxable | 26,359 | 2,582.00 | | | | | | | | | | | | | | | | | | | | | | | | | | | | | | | | | | | | | | | | | | | | | | | | | | | | | | | | | | | | | | | | | | | | | | | | | | | | | | | | | | | | | | | | | | | | | | | | | | | | | | | | | |
| Assessment History <table border="1"> <thead> <tr> <th>Tax Year</th> <th>Statement Number</th> <th>Billed Owner</th> <th>Tax Area</th> <th>Total Value</th> <th>Exemptions</th> <th>Taxable Value</th> <th>Billed Tax</th> </tr> </thead> <tbody> <tr><td>2025</td><td>2025-660095879</td><td>BOYADJIAN, KHATCHIG N</td><td>40</td><td>237,693</td><td>0</td><td>25,104</td><td>2,459.00</td></tr> <tr><td>2024</td><td>2024-660095879</td><td>BOYADJIAN, KHATCHIG N</td><td>40</td><td>256,654</td><td>0</td><td>23,909</td><td>2,297.00</td></tr> <tr><td>2023</td><td>2023-660095879</td><td>BOYADJIAN, KHATCHIG N</td><td>40</td><td>207,000</td><td>0</td><td>22,770</td><td>2,134.00</td></tr> <tr><td>2022</td><td>2022-660095879</td><td>BOYADJIAN, KHATCHIG N</td><td>40</td><td>207,000</td><td>0</td><td>22,770</td><td>2,231.00</td></tr> <tr><td>2021</td><td>2021-660095879</td><td>BOYADJIAN, KHATCHIG N</td><td>40</td><td>194,984</td><td>0</td><td>21,448</td><td>2,075.00</td></tr> <tr><td>2020</td><td>2020-660095879</td><td>TALLMAN, VANCE E</td><td>40</td><td>189,694</td><td>0</td><td>20,861</td><td>2,018.00</td></tr> <tr><td>2019</td><td>2019-660095879</td><td>TALLMAN, VANCE E</td><td>40</td><td>180,619</td><td>0</td><td>19,868</td><td>1,924.00</td></tr> <tr><td>2018</td><td>2018-660095879</td><td>TALLMAN, VANCE E</td><td>40</td><td>180,766</td><td>0</td><td>19,884</td><td>1,854.00</td></tr> <tr><td>2017</td><td>2017-660095879</td><td>TALLMAN, VANCE E</td><td>40</td><td>179,333</td><td>0</td><td>19,727</td><td>1,856.00</td></tr> <tr><td>2016</td><td>2016-660095879</td><td>TALLMAN, VANCE E</td><td>40</td><td>174,874</td><td>0</td><td>19,236</td><td>1,818.00</td></tr> <tr><td>2015</td><td>2015-660095879</td><td>SIMMONS HOMES RESIDENTIAL</td><td>40</td><td>67,007</td><td>0</td><td>4,107</td><td>392.00</td></tr> <tr><td>2014</td><td>2014-660095879</td><td>SIMMONS HOMES RESIDENTIAL</td><td>40</td><td>6,985</td><td>0</td><td>768</td><td>74.00</td></tr> </tbody> </table> | | | | | | | | | | Tax Year | Statement Number | Billed Owner | Tax Area | Total Value | Exemptions | Taxable Value | Billed Tax | 2025 | 2025-660095879 | BOYADJIAN, KHATCHIG N | 40 | 237,693 | 0 | 25,104 | 2,459.00 | 2024 | 2024-660095879 | BOYADJIAN, KHATCHIG N | 40 | 256,654 | 0 | 23,909 | 2,297.00 | 2023 | 2023-660095879 | BOYADJIAN, KHATCHIG N | 40 | 207,000 | 0 | 22,770 | 2,134.00 | 2022 | 2022-660095879 | BOYADJIAN, KHATCHIG N | 40 | 207,000 | 0 | 22,770 | 2,231.00 | 2021 | 2021-660095879 | BOYADJIAN, KHATCHIG N | 40 | 194,984 | 0 | 21,448 | 2,075.00 | 2020 | 2020-660095879 | TALLMAN, VANCE E | 40 | 189,694 | 0 | 20,861 | 2,018.00 | 2019 | 2019-660095879 | TALLMAN, VANCE E | 40 | 180,619 | 0 | 19,868 | 1,924.00 | 2018 | 2018-660095879 | TALLMAN, VANCE E | 40 | 180,766 | 0 | 19,884 | 1,854.00 | 2017 | 2017-660095879 | TALLMAN, VANCE E | 40 | 179,333 | 0 | 19,727 | 1,856.00 | 2016 | 2016-660095879 | TALLMAN, VANCE E | 40 | 174,874 | 0 | 19,236 | 1,818.00 | 2015 | 2015-660095879 | SIMMONS HOMES RESIDENTIAL | 40 | 67,007 | 0 | 4,107 | 392.00 | 2014 | 2014-660095879 | SIMMONS HOMES RESIDENTIAL | 40 | 6,985 | 0 | 768 | 74.00 |
| Tax Year | Statement Number | Billed Owner | Tax Area | Total Value | Exemptions | Taxable Value | Billed Tax | | | | | | | | | | | | | | | | | | | | | | | | | | | | | | | | | | | | | | | | | | | | | | | | | | | | | | | | | | | | | | | | | | | | | | | | | | | | | | | | | | | | | | | | | | | | | | | | | | | | | | | | | | |
| 2025 | 2025-660095879 | BOYADJIAN, KHATCHIG N | 40 | 237,693 | 0 | 25,104 | 2,459.00 | | | | | | | | | | | | | | | | | | | | | | | | | | | | | | | | | | | | | | | | | | | | | | | | | | | | | | | | | | | | | | | | | | | | | | | | | | | | | | | | | | | | | | | | | | | | | | | | | | | | | | | | | | |
| 2024 | 2024-660095879 | BOYADJIAN, KHATCHIG N | 40 | 256,654 | 0 | 23,909 | 2,297.00 | | | | | | | | | | | | | | | | | | | | | | | | | | | | | | | | | | | | | | | | | | | | | | | | | | | | | | | | | | | | | | | | | | | | | | | | | | | | | | | | | | | | | | | | | | | | | | | | | | | | | | | | | | |
| 2023 | 2023-660095879 | BOYADJIAN, KHATCHIG N | 40 | 207,000 | 0 | 22,770 | 2,134.00 | | | | | | | | | | | | | | | | | | | | | | | | | | | | | | | | | | | | | | | | | | | | | | | | | | | | | | | | | | | | | | | | | | | | | | | | | | | | | | | | | | | | | | | | | | | | | | | | | | | | | | | | | | |
| 2022 | 2022-660095879 | BOYADJIAN, KHATCHIG N | 40 | 207,000 | 0 | 22,770 | 2,231.00 | | | | | | | | | | | | | | | | | | | | | | | | | | | | | | | | | | | | | | | | | | | | | | | | | | | | | | | | | | | | | | | | | | | | | | | | | | | | | | | | | | | | | | | | | | | | | | | | | | | | | | | | | | |
| 2021 | 2021-660095879 | BOYADJIAN, KHATCHIG N | 40 | 194,984 | 0 | 21,448 | 2,075.00 | | | | | | | | | | | | | | | | | | | | | | | | | | | | | | | | | | | | | | | | | | | | | | | | | | | | | | | | | | | | | | | | | | | | | | | | | | | | | | | | | | | | | | | | | | | | | | | | | | | | | | | | | | |
| 2020 | 2020-660095879 | TALLMAN, VANCE E | 40 | 189,694 | 0 | 20,861 | 2,018.00 | | | | | | | | | | | | | | | | | | | | | | | | | | | | | | | | | | | | | | | | | | | | | | | | | | | | | | | | | | | | | | | | | | | | | | | | | | | | | | | | | | | | | | | | | | | | | | | | | | | | | | | | | | |
| 2019 | 2019-660095879 | TALLMAN, VANCE E | 40 | 180,619 | 0 | 19,868 | 1,924.00 | | | | | | | | | | | | | | | | | | | | | | | | | | | | | | | | | | | | | | | | | | | | | | | | | | | | | | | | | | | | | | | | | | | | | | | | | | | | | | | | | | | | | | | | | | | | | | | | | | | | | | | | | | |
| 2018 | 2018-660095879 | TALLMAN, VANCE E | 40 | 180,766 | 0 | 19,884 | 1,854.00 | | | | | | | | | | | | | | | | | | | | | | | | | | | | | | | | | | | | | | | | | | | | | | | | | | | | | | | | | | | | | | | | | | | | | | | | | | | | | | | | | | | | | | | | | | | | | | | | | | | | | | | | | | |
| 2017 | 2017-660095879 | TALLMAN, VANCE E | 40 | 179,333 | 0 | 19,727 | 1,856.00 | | | | | | | | | | | | | | | | | | | | | | | | | | | | | | | | | | | | | | | | | | | | | | | | | | | | | | | | | | | | | | | | | | | | | | | | | | | | | | | | | | | | | | | | | | | | | | | | | | | | | | | | | | |
| 2016 | 2016-660095879 | TALLMAN, VANCE E | 40 | 174,874 | 0 | 19,236 | 1,818.00 | | | | | | | | | | | | | | | | | | | | | | | | | | | | | | | | | | | | | | | | | | | | | | | | | | | | | | | | | | | | | | | | | | | | | | | | | | | | | | | | | | | | | | | | | | | | | | | | | | | | | | | | | | |
| 2015 | 2015-660095879 | SIMMONS HOMES RESIDENTIAL | 40 | 67,007 | 0 | 4,107 | 392.00 | | | | | | | | | | | | | | | | | | | | | | | | | | | | | | | | | | | | | | | | | | | | | | | | | | | | | | | | | | | | | | | | | | | | | | | | | | | | | | | | | | | | | | | | | | | | | | | | | | | | | | | | | | |
| 2014 | 2014-660095879 | SIMMONS HOMES RESIDENTIAL | 40 | 6,985 | 0 | 768 | 74.00 | | | | | | | | | | | | | | | | | | | | | | | | | | | | | | | | | | | | | | | | | | | | | | | | | | | | | | | | | | | | | | | | | | | | | | | | | | | | | | | | | | | | | | | | | | | | | | | | | | | | | | | | | | |



Rogers

Assessment Property Record Card for Tax Year 2026

Data provided by LISA DELOZIER County Assessor

Date 04/18/2026
 Time 08:37:45
 Page 2

| Lot Data | | Square-Foot - NBHD 1059 #1 | |
|-----------------|--------------------------|----------------------------|---|
| Lot Size | 0 | 0 | |
| Lot Count | 1 | | |
| Units Buildable | | | |
| Non-Ag Acres | 0.1382 | | |
| Topography | | | |
| Street Access | | | |
| Utilities | | | |
| Amenities | | | 0 |
| | | | 0 |
| Method | Square-Foot | | |
| Base Lot Value | 6,022.00 x 5.30 = 31,917 | | |
| Factor Value | | | |
| Adjustments | 1.0000 | | |
| Lot Value | 31,917 | | |

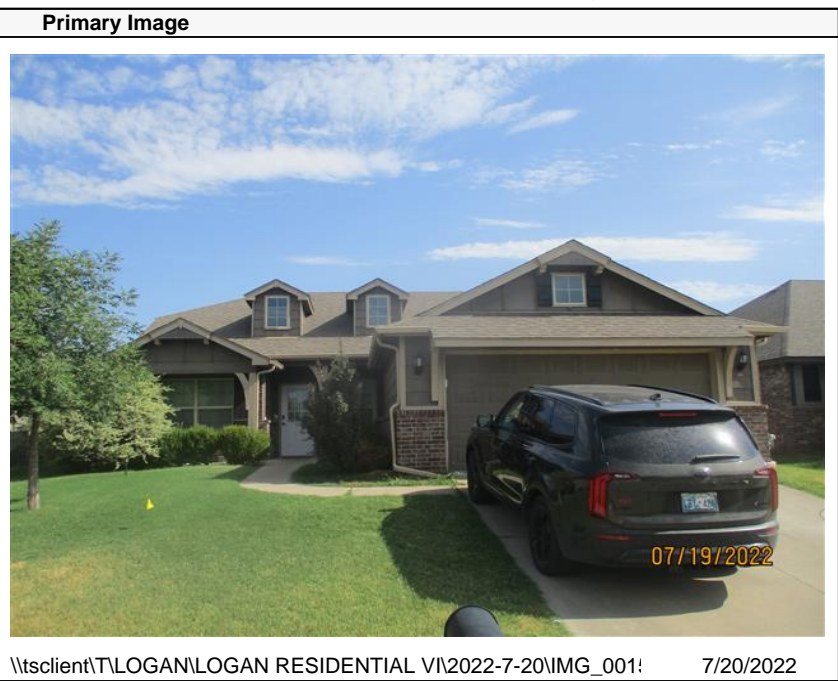

\\tsclient\T\LOGAN\LOGAN RESIDENTIAL VI\2022-7-20\IMG_001! 7/20/2022

| Residential Data | |
|------------------|----------------------------------|
| Type | 1 Single Family Residence |
| Condition | 3 - Average |
| Quality | 3 - Average |
| Architecture | |
| Style | 100% One Story |
| Exterior Wall | 100% Veneer, Masonry |
| Base/Total Area | 1,755 / 1,755 |
| Style | 100% One Story |
| HVAC | 100% Warmed & Cooled Air |
| Roof Cover | 1 Composition Shingle |
| Area on Slab | 1,755 |
| Fixture/RghIn | 7 / |
| Bed/F/H Bath | 3 / 2.0 / |
| Basement Area | |
| Garage Type | 501 Attached Garage - Unfinished |
| Remodel | |
| Year/Eff Age | 2014 / 9 |

| GRM Approach | |
|-----------------|------|
| GRM Code | |
| Gross Rent | 0.00 |
| Indicated Value | |

| Multiple Regression | | | |
|---------------------|---------|--------|----------|
| MRA Code | 1 | Test | |
| Adusted R | 0.8445 | | |
| Indicated Value | 243,433 | 138.71 | Per SqFt |

| Direct Comparables | | | |
|--------------------|---------|------------------|----------|
| Selection Model | A | Adam Test | |
| Adjustment Model | 1 | 2022 Residential | |
| Comparables | 8 | | |
| Indicated Value | 243,900 | | Per SqFt |

| Cost Approach | | Manual : 01/2025 | |
|---------------|-----------|--------------------|-----------|
| Base Cost | 103.07 | Total Misc Impr | + 2,399 |
| Roofing Adj | + 4.51 | Garage Cost | + 15,957 |
| Subfloor Adj | + -2.19 | Total RCN | = 235,660 |
| Heat/Cool Adj | + 12.64 | Depreciation (9%) | - 21,209 |
| Plumbing Adj | + 5.79 | Lump Sums | + 0 |
| Basement Adj | + 0.00 | RCNLD | = 214,451 |
| Adj Base Cost | = 123.82 | Lot Value | + 31,917 |
| Total Area | x 1,755 | Indicated Value | = 246,368 |
| Adjusted Cost | = 217,304 | Value Per SqFt | 140.38 |

| Value Reconciliation | | | |
|----------------------|---------------|--------|----------------------|
| Selected Approach | Cost Approach | | |
| Improvements | 214,451 | | |
| Lot Value | 31,917 | | |
| Indicated Value | 246,368 | 140.38 | Per SqFt |
| Agland Value | | | |
| Site Improvements | | | |
| Total Value | 246,368 | 140.38 | Total Value Per SqFt |

| Miscellaneous Improvements | | | | | | | | |
|----------------------------|--------------------------|-----------|-------|------|-------|-----------|------|-------|
| Code | Description | Sketch ID | Size | Year | Units | Unit Cost | Depr | Value |
| PATO | RAISED SLAB PORCH - OPEN | 120148 | 10x10 | | 100 | 11.48 | | 1,148 |
| PATO | RAISED SLAB PORCH - OPEN | 120149 | 11x5 | | 55 | 11.48 | | 631 |
| PATO | RAISED SLAB PORCH - OPEN | 120150 | 9x6 | | 54 | 11.48 | | 620 |



Rogers

Assessment Property Record Card for Tax Year 2026

Data provided by LISA DELOZIER County Assessor

Date 04/18/2026
 Time 08:37:45
 Page 3

Sketch Image

660095879

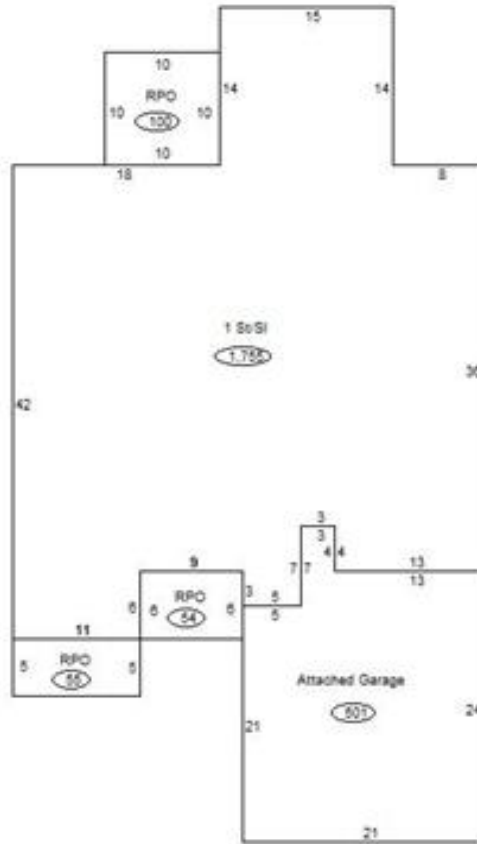

Sketch Vector Information

| Sequence | Code | Type | Built Over | Scale | Section Label | Base Area | Multiplier | Total Area |
|----------------------------|------|------|------------|-------|-----------------|--------------|------------|--------------|
| 1 | R | 1 | Slab | 13 | 1 St/SI | 1,755 | 1.000 | 1,755 |
| 2 | M | PATO | | 13 | Raised Slab | 100 | 1.000 | 100 |
| 3 | M | PATO | | 13 | Raised Slab | 55 | 1.000 | 55 |
| 4 | M | PATO | | 13 | Raised Slab | 54 | 1.000 | 54 |
| 5 | G | 1 | | 13 | Attached Garage | 501 | 1.000 | 501 |
| Total Building Area | | | | | | 1,755 | | 1,755 |