



Rogers

Assessment Property Record Card for Tax Year 2026

Data provided by LISA DELOZIER County Assessor

Date 04/18/2026
Time 09:21:23
Page 1

Assessment Data					Primary Image														
Account 660099648 Parcel ID 23N15E-01-4-00000-000-0099 Cadastral ID 01-23-15-00130 Property Type REAL - Real Property Property Class RA VI Area 2 Tax Area 10 - OOLOGAH RURAL/NW FIRE Name ID 319425 ALBERTSON, TRAVIS L & BRITNEY P 7950 S 4130 RD TALALA OK 74080-0000 Parcel Location Situs 07950 S 4130 RD Subdivision Lot/Block / Parcel Size 10 - Acres Sec/Twn/Rng 1 / 23 / 15 / 4 Neighborhood 4030 - OOLOGAH RURAL School District S004 - OOLOGAH SCHOOLS					 <p>\\tsclient\C\Users\CB\Pictures\2020-03-03\IMG_0088.JPG 3/3/2020</p>														
Legal Description Lat/Long: 36.49661570 -95.65190361																			
SE SE SE.					Building Permits <table border="1"> <thead> <tr> <th>Number</th> <th>Description</th> <th>Opened</th> <th>Closed</th> <th>Amount</th> </tr> </thead> <tbody> <tr> <td>R2016 12 4</td> <td>R18-NEW 1426 SQ FT SFR</td> <td>12/2016</td> <td>06/2017</td> <td>127,000</td> </tr> </tbody> </table>					Number	Description	Opened	Closed	Amount	R2016 12 4	R18-NEW 1426 SQ FT SFR	12/2016	06/2017	127,000
Number	Description	Opened	Closed	Amount															
R2016 12 4	R18-NEW 1426 SQ FT SFR	12/2016	06/2017	127,000															
Exemptions					Sale History														
Code	Type	Active	Maximum	Exemption	Bk/Pg	Grantor	Date	Price	Code										
H	Homestead	Yes	1,000	1,000	2616/820	HART, NEDRA &	03/09/2017		6										
					2579/205	HART, NEDRA &	09/22/2016	0	4										
Parcel Valuation																			
Source	REAL		Fair Cash	Capped	Asmnt Level	Assessed	Levy Rate	108.182	Current Tax										
Remove Cap	0	Land Value	360	360	11%	40	Assessed	17,865	1,932.66										
Year Frozen	0	Improvements	235,260	162,047		17,825	Penalty	0											
Uncapped Value	0	Mobile Home	0	0		0	Exemption	1,000	-95.00										
TIF Project ID	0	Total Value	235,620	162,407		17,865	Total Taxable	16,865	1,838.00										
Assessment History																			
Tax Year	Statement Number	Billed Owner			Tax Area	Total Value	Exemptions	Taxable Value	Billed Tax										
2025	2025-660099648	ALBERTSON, TRAVIS L & BRITNEY P			10	220,835	1000	16,345	1,782.00										
2024	2024-660099648	ALBERTSON, TRAVIS L & BRITNEY P			10	205,366	1000	15,840	1,673.00										
2023	2023-660099648	ALBERTSON, TRAVIS L & BRITNEY P			10	171,421	1000	15,349	1,610.00										
2022	2022-660099648	ALBERTSON, TRAVIS L & BRITNEY P			10	173,201	1000	14,873	1,553.00										
2021	2021-660099648	ALBERTSON, TRAVIS L & BRITNEY P			10	142,667	1000	14,411	1,516.00										
2020	2020-660099648	ALBERTSON, TRAVIS L & BRITNEY P			10	138,713	1000	13,962	1,491.00										
2019	2019-660099648	ALBERTSON, TRAVIS L & BRITNEY P			10	132,056	1000	13,527	1,418.00										
2018	2018-660099648	ALBERTSON, TRAVIS L & BRITNEY P			10	134,635	1000	13,810	1,497.00										
2017	2017-660099648	ALBERTSON, TRAVIS L & BRITNEY P			10	360	0	40	5.00										
2016	2016-660099648	ALBERTSON, TRAVIS L & BRITNEY P			10	360	0	40	5.00										



Rogers

Assessment Property Record Card for Tax Year 2026

Data provided by LISA DELOZIER County Assessor

Date 04/18/2026
 Time 09:21:23
 Page 2

Lot Data Units-Buildable - OOLOGAH RURAL (UNITS BUILDABLE)	
Lot Size	
Lot Count	
Units Buildable	
Non-Ag Acres	
Topography	
Street Access	
Utilities	
Amenities	LAND QUALITY
Method	Units-Buildable
Base Lot Value	
Factor Value	
Adjustments	
Lot Value	



\\tsclient\C\Users\CB\Pictures\2020-03-03\IMG_0088.JPG 3/3/2020

Residential Data	
Type	1 Single Family Residence
Condition	3 - Average
Quality	3 - Average
Architecture	TRAD TRADITIONAL
Style	100% One Story
Exterior Wall	80% Frame, Siding, Wood 20% Veneer, Masonry
Base/Total Area	1,451 / 1,451
Style	100% One Story
HVAC	100% Warmed & Cooled Air
Roof Cover	1 Composition Shingle
Area on Slab	1,451
Fixture/RghIn	11 /
Bed/F/H Bath	3 / 2.0 /
Basement Area	
Garage Type	441 Attached Garage - Finished
Remodel	
Year/Eff Age	2017 / 7

GRM Approach	
GRM Code	
Gross Rent	0.00
Indicated Value	

Multiple Regression	
MRA Code	
Adusted R	
Indicated Value	

Direct Comparables	
Selection Model	A Adam Test
Adjustment Model	A2 AO Test
Comparables	
Indicated Value	

Cost Approach		Manual : 01/2025	
Base Cost	105.48	Total Misc Impr	+ 7,272
Roofing Adj	+ 4.91	Garage Cost	+ 18,200
Subfloor Adj	+ -2.37	Total RCN	= 216,061
Heat/Cool Adj	+ 12.64	Depreciation (7%)	- 15,124
Plumbing Adj	+ 10.69	Lump Sums	+ 0
Basement Adj	+ 0.00	RCNLD	= 200,937
Adj Base Cost	= 131.35	Lot Value	+ 200,937
Total Area	x 1,451	Indicated Value	= 200,937
Adjusted Cost	= 190,589	Value Per SqFt	138.48

Value Reconciliation			
Selected Approach	Cost Approach		
Improvements	200,937		
Lot Value			
Indicated Value	200,937	138.48	Per SqFt
Agland Value	360		
Site Improvements	34,323		
Total Value	235,620	162.38	Total Value Per SqFt

Miscellaneous Improvements								
Code	Description	Sketch ID	Size	Year	Units	Unit Cost	Depr	Value
SHLT	STORM SHELTER	0		1	1	0.00		
PRCH	SLAB PORCH - COVERED	133790		114	114	26.57		3,029
PRCH	Porch	133791	12x12		144	26.48		3,813
PRCH	Porch	163265	4x4		16	26.88		430



Rogers

Assessment Property Record Card for Tax Year 2026

Data provided by LISA DELOZIER County Assessor

Date 04/18/2026
 Time 09:21:23
 Page 3

Sketch Image

660099648

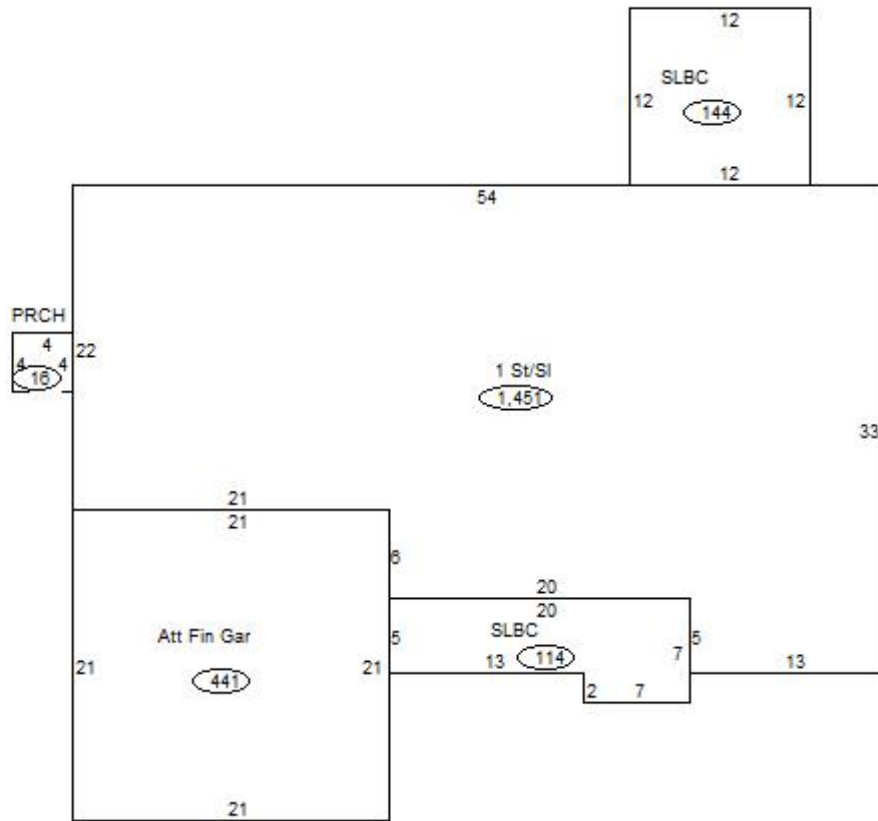

Sketch Vector Information

Sequence	Code	Type	Built Over	Scale	Section Label	Base Area	Multiplier	Total Area
1	R	1	Slab	13	1 St/Sl	1,451	1.000	1,451
2	G	5		13	Att Fin Gar	441	1.000	441
3	M	PRCH		13	SLBC	114	1.000	114
4	M	PRCH		13	SLBC	144	1.000	144
5	M	PRCH		13	PRCH	16	1.000	16
Total Building Area						1,451		1,451



Rogers

Assessment Property Record Card for Tax Year 2026

Data provided by LISA DELOZIER County Assessor

Date 04/18/2026
 Time 09:21:24
 Page 4

660099648

Outbuildings/Site Improvements

Building Image	Code	Description	Dimensions	Floor	Roofing	Total Units
	UTIL	Shop Building	32x32x8	Concrete	Formed Metal	1,024
	Qual 3	Cond 3	Year 2023	Eff Age 2		

Valuation Summary	Modifier Total	RCN	Depr (3% Phys/ % Func)	RCNLD
Base Cost (31.73 x 1,024) 32,492			32,492 975	31,517

LOAF	Loafing Shed	24x12x10	Dirt	Formed Metal	288
Qual 3	Cond 3	Year 2020	Eff Age 5		

Valuation Summary	Modifier Total	RCN	Depr (23% Phys/ % Func)	RCNLD
Base Cost (7.12 x 288) 2,051			2,051 472	1,579

LF	LOAFING SHED	24x12x0			288
Qual	Cond	Year	Eff Age		



Valuation Summary	Modifier Total	RCN	Depr (0% Phys/ % Func)	RCNLD
Base Cost (4.26 x 288) 1,227			1,227	1,227



Rogers

Assessment Property Record Card for Tax Year 2026

Data provided by LISA DELOZIER County Assessor

Date 04/18/2026
Time 09:21:24
Page 5

Agland Inventory

660099648

Soi	Description	Land Use	LPI	Adj Type	Adj Code	Acres	Use/Acre	Mkt/Acre	Use Value	Market Value
SO	SOGN SOILS	NTV PST	15			10.000	36	36	360	360
NTV PST Totals						10.000			360	360
Total Agland						10.000			360	360