



Rogers

Assessment Property Record Card for Tax Year 2026

Data provided by LISA DELOZIER County Assessor

Date 04/18/2026
Time 09:29:30
Page 1

Assessment Data					Primary Image				
Account	660100246								
Parcel ID	00000-00-0-000172-004-0005								
Cadastral ID	35-23-14-01910								
Property Type	REAL - Real Property								
Property Class	RRP	VI Area	2						
Tax Area	10 - OOLOGAH RURAL/NW FIRE								
Name ID	328116								
THE RIVER LIFE TRUST									
2852 CROSSCREEK DR OOLOGAH OK 74053-0000									
Parcel Location									
Situs	02852 CROSSCREEK DR								
Subdivision	CLEAR CREEK AT WOODSIDE PHASE IV								
Lot/Block	0005 / 0004	Parcel Size	1 - Lots						
Sec/Twn/Rng	35 / 23 / 14 / 5								
Neighborhood	1021 - R-V02-NW OOLOGAH								
School District	S004 - OOLOGAH SCHOOLS								
Legal Description Lat/Long: 36.43123760 -95.77943324									
LOT 5 BLOCK 4 CLEAR CREEK AT WOODSIDE PHASE IV									
Building Permits									
Number	Description	Opened	Closed	Amount					
R19 000421	R21- NEW 40X60 DTCH ACC BLDG	11/2019	06/2020						
R19 000242	R20- NEW 2560 SQ FT SFR	07/2019	01/2020	288,000					
Exemptions									
Code	Type	Active	Maximum	Exemption					
H	Homestead	Yes	1,000	1,000					
Sale History									
Bk/Pg	Grantor	Date	Price	Code					
/	DOUBLE H PROPERTIES LLC	06/26/2019	43,000	17					
Parcel Valuation									
Source	REAL	Fair Cash	Capped	Asmnt Level	Assessed	Levy Rate	108.182	Current Tax	
Remove Cap	2020	Land Value	86,775	69,023	11%	7,593	Assessed	46,718 5,054.03	
Year Frozen	2021	Improvements	447,158	355,678		39,125	Penalty	0	
Uncapped Value	0	Mobile Home	0	0		0	Exemption	1,000 -94.00	
TIF Project ID	0	Total Value	533,933	424,701		46,718	Total Taxable	45,718 4,960.00	
Assessment History									
Tax Year	Statement Number	Billed Owner	Tax Area	Total Value	Exemptions	Taxable Value	Billed Tax		
2025	2025-660100246	THE RIVER LIFE TRUST	10	517,633	1000	45,718	4,960.00		
2024	2024-660100246	THE RIVER LIFE TRUST	10	531,463	1000	45,717	4,802.00		
2023	2023-660100246	THE RIVER LIFE TRUST	10	453,879	1000	45,717	4,769.00		
2022	2022-660100246	THE RIVER LIFE TRUST	10	457,253	1000	45,718	4,746.00		
2021	2021-660100246	THE RIVER LIFE TRUST	10	424,701	1000	45,717	4,779.00		
2020	2020-660100246	THE RIVER LIFE TRUST	10	346,668	0	38,133	4,034.00		
2019	2019-660100246	THE RIVER LIFE TRUST	10	7,199	0	792	82.00		
2018	2018-660100246	DOUBLE H PROPERTIES LLC	10	7,199	0	792	85.00		



Rogers

Assessment Property Record Card for Tax Year 2026

Data provided by LISA DELOZIER County Assessor

Date 04/18/2026
Time 09:29:30
Page 2

Lot Data	Square-Foot - NBHD 1021 #1	Primary Image
Lot Size	0 0	
Lot Count	1	
Units Buildable		
Non-Ag Acres	1.3841	
Topography		
Street Access		
Utilities		
Amenities	LAND QUALITY 0	
	0	
Method	Square-Foot	
Base Lot Value	60,293.00 x 1.44 = 86,775	
Factor Value		
Adjustments	1.0000	
Lot Value	86,775	

Residential Data	
Type	1 Single Family Residence
Condition	3 - Average
Quality	3.5 - Average
Architecture	
Style	100% One Story
Exterior Wall	95% Veneer, Masonry 5% Veneer, Stone
Base/Total Area	2,485 / 2,485
Style	100% One Story
HVAC	100% Warmed & Cooled Air
Roof Cover	1 Composition Shingle
Area on Slab	2,485
Fixture/RghIn	11 /
Bed/F/H Bath	3 / 2.0 /
Basement Area	
Garage Type	828 Attached Garage - Unfinished
Remodel	
Year/Eff Age	2019 / 5

660100246	06/04/24
660100246_001.JPG	6/17/2024

GRM Approach	
GRM Code	
Gross Rent	0.00
Indicated Value	

Multiple Regression			
MRA Code	1	Test	
Adusted R	0.8445		
Indicated Value	450,749	181.39	Per SqFt

Direct Comparables			
Selection Model	A	Adam Test	
Adjustment Model	1	2022 Residential	
Comparables	1		
Indicated Value	219,950		Per SqFt

Cost Approach				Manual : 01/2025			
Base Cost	109.06	Total Misc Impr	+	23,034			
Roofing Adj	+ 5.16	Garage Cost	+	30,810			
Subfloor Adj	+ -3.38	Total RCN	=	382,982			
Heat/Cool Adj	+ 14.47	Depreciation (5%)	-	19,149			
Plumbing Adj	+ 7.14	Lump Sums	+	0			
Basement Adj	+ 0.00	RCNLD	=	363,833			
Adj Base Cost	= 132.45	Lot Value	+	86,775			
Total Area	x 2,485	Indicated Value	=	450,608			
Adjusted Cost	= 329,138	Value Per SqFt		181.33			

Value Reconciliation			
Selected Approach	Cost Approach		
Improvements	363,833		
Lot Value	86,775		
Indicated Value	450,608	181.33	Per SqFt
Agland Value			
Site Improvements	83,325		
Total Value	533,933	214.86	Total Value Per SqFt

Miscellaneous Improvements								
Code	Description	Sketch ID	Size	Year	Units	Unit Cost	Depr	Value
FPR1	FIREPLACE - RESIDENTIAL 1 STORY	0		1	1	6,429.63		6,430
PRCH	SLAB PORCH - COVERED	144364		397	397	28.16		11,180
PRCH	SLAB PORCH - COVERED	144365		188	188	28.85		5,424



Rogers

Assessment Property Record Card for Tax Year 2026

Data provided by LISA DELOZIER County Assessor

Date 04/18/2026

Time 09:29:30

Page 3

Sketch Image

660100246

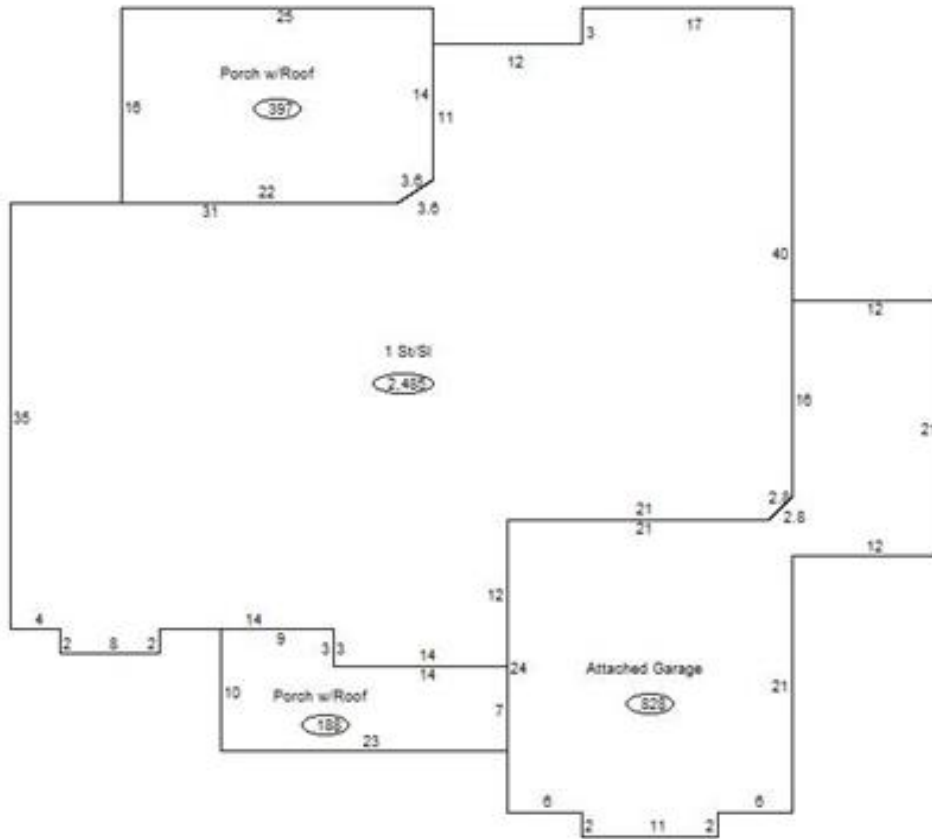

Sketch Vector Information

Sequence	Code	Type	Built Over	Scale	Section Label	Base Area	Multiplier	Total Area
1	R	1	Slab	13	1 St/Sl	2,485	1.000	2,485
2	G	1		13	Attached Garage	828	1.000	828
3	M	PRCH		13	SLBC	397	1.000	397
4	M	PRCH		13	SLBC	188	1.000	188
Total Building Area						2,485		2,485



Rogers



Assessment Property Record Card for Tax Year 2026

Data provided by LISA DELOZIER County Assessor

Date 04/18/2026
Time 09:29:30
Page 4

660100246

Outbuildings/Site Improvements

Building Image	Code	Description	Dimensions	Floor	Roofing	Total Units
	GRDT	GARAGE - DETACHED	60x40x0			2,400
	Qual 4	Cond 3	Year 2020	Eff Age	5	
	Valuation Summary		Modifier Total	RCN	Depr (9% Phys/ % Func)	RCNLD
Base Cost (37.96 x 2,400)		91,104		91,104	8,199	82,905
	LNT0	LEAN TO - ATTACHED	8x8x0			64
	Qual 3	Cond 3	Year 2020	Eff Age	5	
	Valuation Summary		Modifier Total	RCN	Depr (31% Phys/ % Func)	RCNLD
Base Cost (9.50 x 64)		608		608	188	420