



Rogers

Assessment Property Record Card for Tax Year 2026

Data provided by LISA DELOZIER County Assessor

Date 04/18/2026
Time 09:29:44
Page 1

Assessment Data					Primary Image				
Account	660100254				<p>660100254_002.JPG 6/17/2024</p>				
Parcel ID	00000-00-0-000172-005-0006								
Cadastral ID	35-23-14-01990								
Property Type	REAL - Real Property								
Property Class	RRP	VI Area 2							
Tax Area	10 - OOLOGAH RURAL/NW FIRE								
Name ID	332474								
JARRED, JOHN M & NATALIE K									
2831 CROSSCREEK DR OOLOGAH OK 74080-0000									
Parcel Location									
Situs	02831 CROSSCREEK DR								
Subdivision	CLEAR CREEK AT WOODSIDE PHASE IV								
Lot/Block	0006 / 0005	Parcel Size 1 - Lots							
Sec/Twn/Rng	35 / 23 / 14 / 5								
Neighborhood	1021 - R-V02-NW OOLOGAH								
School District	S004 - OOLOGAH SCHOOLS								
Legal Description Lat/Long: 36.43217122 -95.78006974									
Building Permits									
LOT 6 BLOCK 5 CLEAR CREEK AT WOODSIDE PHASE IV									
Number	Description	Opened	Closed	Amount					
R22 068	R23 NEW DTCH ACC BLDG 50X40	03/2022	06/2022	65,000					
R20	R23- POSS NEW CONST PER MRTGE	11/2020	06/2022	399,000					
Exemptions									
Code	Type	Active	Maximum	Exemption					
H	Homestead	Yes	1,000	1,000					
Sale History									
Bk/Pg	Grantor	Date	Price	Code					
/	DOUBLE H PROPERTIES LLC	10/19/2020	0	4					
/	HOLLY CONSTRUCTION INC	10/19/2020	49,500	YES					
Parcel Valuation									
Source	REAL	Fair Cash	Capped	Asmnt Level	Assessed	Levy Rate	108.182	Current Tax	
Remove Cap	2021	Land Value	84,998	84,998	11%	9,350	Assessed	59,286 6,413.65	
Year Frozen		Improvements	473,314	453,969		49,936	Penalty	0	
Uncapped Value	0	Mobile Home	0	0		0	Exemption	1,000 -95.00	
TIF Project ID	0	Total Value	558,312	538,967		59,286	Total Taxable	58,286 6,319.00	
Assessment History									
Tax Year	Statement Number	Billed Owner	Tax Area	Total Value	Exemptions	Taxable Value	Billed Tax		
2025	2025-660100254	JARRED, JOHN M &	10	523,269	1000	56,560	6,133.00		
2024	2024-660100254	JARRED, JOHN M &	10	531,387	1000	55,005	5,775.00		
2023	2023-660100254	JARRED, JOHN M &	10	494,307	1000	53,374	5,565.00		
2022	2022-660100254	JARRED, JOHN M &	10	50,000	0	5,500	569.00		
2021	2021-660100254	JARRED, JOHN M &	10	50,000	0	5,500	574.00		
2020	2020-660100254	DOUBLE H PROPERTIES LLC	10	7,199	0	792	84.00		
2019	2019-660100254	DOUBLE H PROPERTIES LLC	10	7,199	0	792	82.00		
2018	2018-660100254	DOUBLE H PROPERTIES LLC	10	7,199	0	792	85.00		



Rogers

Assessment Property Record Card for Tax Year 2026

Data provided by LISA DELOZIER County Assessor

Date 04/18/2026
 Time 09:29:45
 Page 2

Lot Data		Square-Foot - NBHD 1021 #1	
Lot Size	0	0	
Lot Count	1		
Units Buildable			
Non-Ag Acres	1.3025		
Topography			
Street Access			
Utilities			
Amenities	LAND QUALITY		0
			0
Method	Square-Foot		
Base Lot Value	56,739.00 x 1.50 = 84,998		
Factor Value			
Adjustments	1.0000		
Lot Value	84,998		



660100254_002.JPG 6/17/2024

Residential Data	
Type	1 Single Family Residence
Condition	3 - Average
Quality	3 - Average
Architecture	
Style	100% One Story
Exterior Wall	100% Veneer, Masonry
Base/Total Area	3,062 / 3,062
Style	100% One Story
HVAC	100% Warmed & Cooled Air
Roof Cover	1 Composition Shingle
Area on Slab	3,062
Fixture/RghIn	/
Bed/F/H Bath	4 / 3.0 / 1.0
Basement Area	
Garage Type	996 Attached Garage - Finished
Remodel	
Year/Eff Age	2022 / 3

GRM Approach	
GRM Code	
Gross Rent	0.00
Indicated Value	

Multiple Regression			
MRA Code	1	Test	
Adusted R	0.8445		
Indicated Value	458,716	149.81	Per SqFt

Direct Comparables	
Selection Model	A Adam Test
Adjustment Model	1 2022 Residential
Comparables	
Indicated Value	

Cost Approach		Manual : 01/2025	
Base Cost	99.89	Total Misc Impr	+ 23,258
Roofing Adj	+ 4.36	Garage Cost	+ 37,191
Subfloor Adj	+ -2.06	Total RCN	= 430,247
Heat/Cool Adj	+ 12.64	Depreciation (3%)	- 12,907
Plumbing Adj	+ 5.94	Lump Sums	+ 0
Basement Adj	+ 0.00	RCNLD	= 417,340
Adj Base Cost	= 120.77	Lot Value	+ 84,998
Total Area	x 3,062	Indicated Value	= 502,338
Adjusted Cost	= 369,798	Value Per SqFt	164.06

Value Reconciliation			
Selected Approach	Cost Approach		
Improvements	417,340		
Lot Value	84,998		
Indicated Value	502,338	164.06	Per SqFt
Agland Value			
Site Improvements	55,974		
Total Value	558,312	182.34	Total Value Per SqFt

Miscellaneous Improvements								
Code	Description	Sketch ID	Size	Year	Units	Unit Cost	Depr	Value
PRCH	Slab Porch - Covered	154058	492		492	25.39		12,492
PRCH	Slab Porch - Covered	154059	106		106	26.60		2,820
ODFP	Outdoor Fireplace/Firepit			1	1	2,751.55		2,752
FPPF	Fireplace - Prefabricated			1	1	5,194.00		5,194



Rogers

Assessment Property Record Card for Tax Year 2026

Data provided by LISA DELOZIER County Assessor

Date 04/18/2026
 Time 09:29:45
 Page 3

Sketch Image

660100254

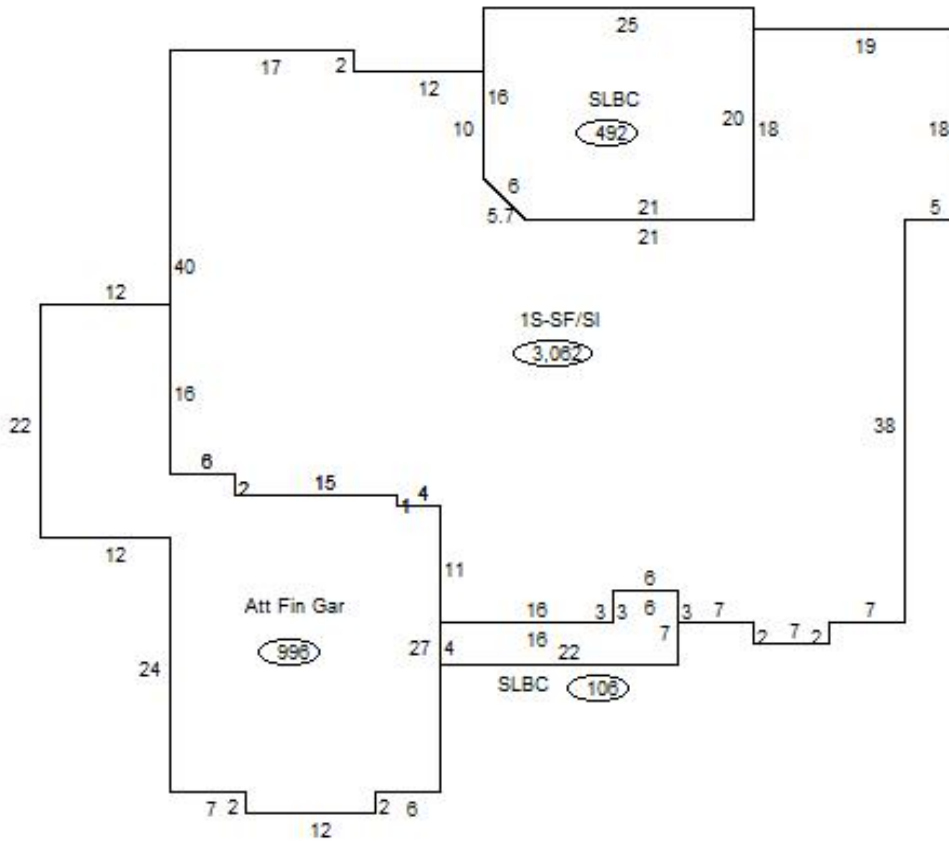

Sketch Vector Information

Sequence	Code	Type	Built Over	Scale	Section Label	Base Area	Multiplier	Total Area
1	R	1	Slab	20	1S-SF/SI	3,062	1.000	3,062
2	G	5		20	Att Fin Gar	996	1.000	996
3	M	PRCH		20	SLBC	492	1.000	492
4	M	PRCH		20	SLBC	106	1.000	106
Total Building Area						3,062		3,062



Rogers

Assessment Property Record Card for Tax Year 2026

Data provided by LISA DELOZIER County Assessor

Date 04/18/2026
 Time 09:29:45
 Page 4

660100254

Outbuildings/Site Improvements

Building Image	Code	Description	Dimensions	Floor	Roofing	Total Units
	UTIL	Shop Building	40x50x0			2,000
	Qual	3	Cond 3	Year	2022	Eff Age 3
						0
						0
		Valuation Summary	Modifier Total	RCN	Depr (5% Phys/ % Func)	RCNLD
		Base Cost (29.46 x 2,000)	58,920	58,920	2,946	55,974