



Rogers

Assessment Property Record Card for Tax Year 2026

Data provided by LISA DELOZIER County Assessor

Date 04/18/2026
Time 09:29:52
Page 1

Assessment Data					Primary Image				
Account	660100258				<p>660100258_001.JPG 6/17/2024</p>				
Parcel ID	0000000-00-00172-004-0002								
Cadastral ID	35-23-14-01880								
Property Type	REAL - Real Property								
Property Class	RRP	VI Area	2						
Tax Area	10 - OOLOGAH RURAL/NW FIRE								
Name ID	337578								
NIDEY, BARRETT M & STEPHANIE M HUBELE									
PO BOX 14 OOLOGAH OK 74053-0000									
Parcel Location									
Situs	02950 CROSSCREEK DR								
Subdivision	CLEAR CREEK AT WOODSIDE PHASE IV								
Lot/Block	0002 / 0004	Parcel Size	1 - Lots						
Sec/Twn/Rng	35 / 23 / 14 / 5								
Neighborhood	1021 - R-V02-NW OOLOGAH								
School District	S004 - OOLOGAH SCHOOLS								
Legal Description Lat/Long: 36.43119341 -95.77757740									
LOT 2 BLOCK 4 CLEAR CREEK AT WOODSIDE PHASE IV									
Building Permits									
Number	Description	Opened	Closed	Amount					
R22	R23 POSS NEW SFR PER MORTGAGE	03/2022	04/2023	351,583					
Exemptions									
Code	Type	Active	Maximum	Exemption					
H	Homestead	Yes	1,000	1,000					
Sale History									
Bk/Pg	Grantor	Date	Price	Code					
/	DOUBLE H PROPERTIES LLC	03/03/2022	0	4					
/	HOLLY CONSTRUCTION LLC	03/03/2022	49,500	19					
Parcel Valuation									
Source	REAL	Fair Cash	Capped	Asmnt Level	Assessed	Levy Rate	108.182	Current Tax	
Remove Cap	2023	Land Value	96,068	90,744	11%	9,982	Assessed	53,303 5,766.40	
Year Frozen		Improvements	399,283	393,823		43,321	Penalty	0	
Uncapped Value	0	Mobile Home	0	0		0	Exemption	1,000 -94.00	
TIF Project ID	0	Total Value	495,351	484,567		53,303	Total Taxable	52,303 5,672.00	
Assessment History									
Tax Year	Statement Number	Billed Owner	Tax Area	Total Value	Exemptions	Taxable Value	Billed Tax		
2025	2025-660100258	NIDEY, BARRETT M &	10	478,421	1000	50,750	5,504.00		
2024	2024-660100258	NIDEY, BARRETT M &	10	475,749	1000	49,243	5,171.00		
2023	2023-660100258	NIDEY, BARRETT M &	10	49,500	1000	4,445	476.00		
2022	2022-660100258	NIDEY, BARRETT M &	10	7,199	0	792	82.00		
2021	2021-660100258	DOUBLE H PROPERTIES LLC	10	7,199	0	792	83.00		
2020	2020-660100258	DOUBLE H PROPERTIES LLC	10	7,199	0	792	84.00		
2019	2019-660100258	DOUBLE H PROPERTIES LLC	10	7,199	0	792	82.00		
2018	2018-660100258	DOUBLE H PROPERTIES LLC	10	7,199	0	792	85.00		



Rogers

Assessment Property Record Card for Tax Year 2026

Data provided by LISA DELOZIER County Assessor

Date 04/18/2026
 Time 09:29:52
 Page 2

Lot Data		Square-Foot - NBHD 1021 #1	
Lot Size			
Lot Count			
Units Buildable			
Non-Ag Acres	1.2597		
Topography			
Street Access			
Utilities			
Amenities	LAND QUALITY	0	0
Method	Square-Foot		
Base Lot Value	54,871.00 x 1.53 = 84,064		
Factor Value			
Adjustments	1.1428		
Lot Value	96,068		



660100258_001.JPG

6/17/2024

Residential Data	
Type	1 Single Family Residence
Condition	3 - Average
Quality	3 - Average
Architecture	
Style	100% One Story
Exterior Wall	100% Veneer, Masonry
Base/Total Area	2,846 / 2,846
Style	100% One Story
HVAC	100% Warmed & Cooled Air
Roof Cover	1 Composition Shingle
Area on Slab	2,846
Fixture/RghIn	/
Bed/F/H Bath	4 / 2.0 / 1.0
Basement Area	
Garage Type	1,147 Attached Garage - Finished
Remodel	
Year/Eff Age	2023 / 2

GRM Approach	
GRM Code	
Gross Rent	0.00
Indicated Value	

Multiple Regression	
MRA Code	
Adjusted R	
Indicated Value	

Direct Comparables	
Selection Model	A Adam Test
Adjustment Model	1 2022 Residential
Comparables	
Indicated Value	

Cost Approach				Manual : 01/2025			
Base Cost	101.07	Total Misc Impr	+ 20,152				
Roofing Adj	+ 4.41	Garage Cost	+ 42,829				
Subfloor Adj	+ -2.07	Total RCN	= 407,432				
Heat/Cool Adj	+ 12.64	Depreciation (2%)	- 8,149				
Plumbing Adj	+ 4.98	Lump Sums	+ 0				
Basement Adj	+ 0.00	RCNLD	= 399,283				
Adj Base Cost	= 121.03	Lot Value	+ 96,068				
Total Area	x 2,846	Indicated Value	= 495,351				
Adjusted Cost	= 344,451	Value Per SqFt	174.05				

Value Reconciliation			
Selected Approach	Cost Approach		
Improvements	399,283		
Lot Value	96,068		
Indicated Value	495,351	174.05	Per SqFt
Agland Value			
Site Improvements			
Total Value	495,351	174.05	Total Value Per SqFt

Miscellaneous Improvements								
Code	Description	Sketch ID	Size	Year	Units	Unit Cost	Depr	Value
PRCH	Slab Porch - Covered	156848	138		138	26.50		3,657
PRCH	Slab Porch - Covered	156849	25x17		425	25.60		10,880
FPR1	Fireplace - Residential 1 Story			1 2023	1	5,615.40		5,615



Rogers

Assessment Property Record Card for Tax Year 2026

Data provided by LISA DELOZIER County Assessor

Date 04/18/2026
 Time 09:29:52
 Page 3

Sketch Image

660100258

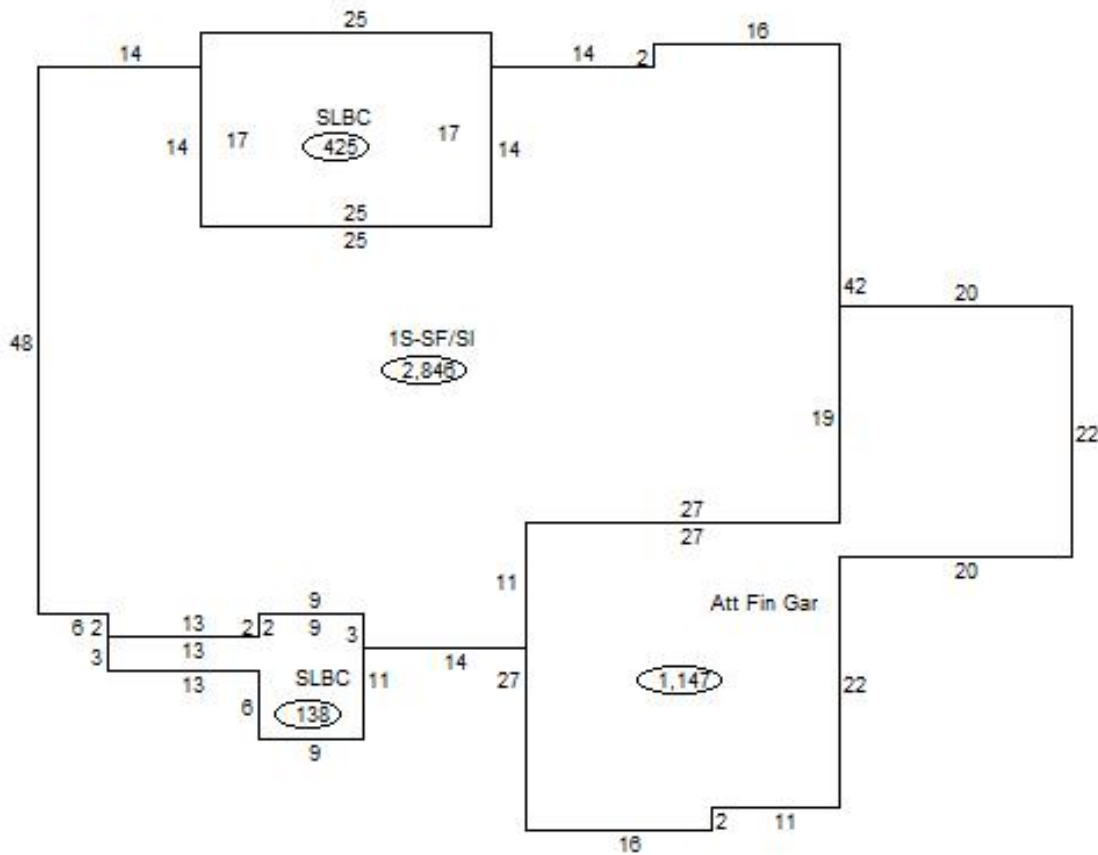

Sketch Vector Information

Sequence	Code	Type	Built Over	Scale	Section Label	Base Area	Multiplier	Total Area
1	R	1	Slab	20	1S-SF/SI	2,846	1.000	2,846
2	G	5		20	Att Fin Gar	1,147	1.000	1,147
3	M	PRCH		20	SLBC	138	1.000	138
4	M	PRCH		20	SLBC	425	1.000	425
Total Building Area						2,846		2,846