



Rogers

Assessment Property Record Card for Tax Year 2026

Data provided by LISA DELOZIER County Assessor

Date 04/18/2026
Time 09:31:11
Page 1

Assessment Data					Primary Image				
Account 660100350 Parcel ID 21N16E-10-2-00000-000-0001 Cadastral ID 10-21-16-10210 Property Type REAL - Real Property Property Class UR VI Area 1 Tax Area 17 - CLAREMORE OT Name ID 338856 NEWPORT PROPERTIES LLC 500 S LYNN RIGGS BLVD 136 CLAREMORE OK 74017-0000 Parcel Location Situs 01007 N OKLAHOMA AVE Subdivision Lot/Block / Parcel Size .22 - Acres Sec/Twn/Rng 10 / 21 / 16 / 2 Neighborhood 2116 - UNPLATTED School District S001 - CLAREMORE SCHOOLS					<p>\\tsclient\T\LOGAN\LOGAN RESIDENTIAL VI\2023-6-28\IMG_003! 6/28/2023</p>				
Legal Description Lat/Long: 36.31688385 -95.59609667									
N 65' S 876' E 150' W 300' W2 SW NW					Building Permits				
					Number	Description	Opened	Closed	Amount
					R18	R19-NEW DUPLEX	11/2017	02/2018	
Exemptions					Sale History				
Code	Type	Active	Maximum	Exemption	Bk/Pg	Grantor	Date	Price	Code
					/	CLAREMORE PROPERTY DEV LLC	06/21/2022	230,000	YES
					/	DAKE PROPERTIES INC	04/05/2019	0	5
					2631/903	DAKE PROPERTIES INC	04/09/2017	0	4
Parcel Valuation									
Source	REAL		Fair Cash	Capped	Asmnt Level	Assessed	Levy Rate	92.430	Current Tax
Remove Cap	2023	Land Value	8,580	8,580	11%	944	Assessed	29,170	2,696.18
Year Frozen		Improvements	256,601	256,601		28,226	Penalty	0	
Uncapped Value	0	Mobile Home	0	0		0	Exemption	0	0.00
TIF Project ID	0	Total Value	265,181	265,181		29,170	Total Taxable	29,170	2,696.00
Assessment History									
Tax Year	Statement Number	Billed Owner			Tax Area	Total Value	Exemptions	Taxable Value	Billed Tax
2025	2025-660100350	NEWPORT PROPERTIES LLC			17	254,528	0	27,893	2,578.00
2024	2024-660100350	NEWPORT PROPERTIES LLC			17	271,987	0	26,565	2,455.00
2023	2023-660100350	NEWPORT PROPERTIES LLC			17	230,000	0	25,300	2,317.00
2022	2022-660100350	NEWPORT PROPERTIES LLC			17	205,817	0	21,927	2,030.00
2021	2021-660100350	CLAREMORE PROPERTY DEV LLC			17	189,841	0	20,883	1,844.00
2020	2020-660100350	CLAREMORE PROPERTY DEV LLC			17	188,226	0	20,541	1,881.00
2019	2019-660100350	CLAREMORE PROPERTY DEV LLC			17	177,843	0	19,563	1,812.00
2018	2018-660100350	DAKE PROPERTIES INC			17	12,595	0	1,385	128.00
2017	2017-660100350	DAKE PROPERTIES INC			17	8,494	0	934	86.00



Rogers

Assessment Property Record Card for Tax Year 2026

Data provided by LISA DELOZIER County Assessor

Date 04/18/2026
Time 09:31:11
Page 2

Lot Data	Square-Foot - NBHD 2116 #1	Primary Image
Lot Size Lot Count Units Buildable Non-Ag Acres 0.2238 Topography Street Access Utilities Amenities LAND QUALITY 0 0 Method Square-Foot Base Lot Value 9,750.00 x .88 = 8,580 Factor Value Adjustments 1.0000 Lot Value 8,580		

Residential Data	
Type	5 Duplex
Condition	3 - Average
Quality	3 - Average
Architecture	
Style	100% One Story
Exterior Wall	100% Veneer, Masonry
Base/Total Area	1,936 / 1,936
Style	100% One Story
HVAC	100% Warmed & Cooled Air
Roof Cover	1 Composition Shingle
Area on Slab	1,936
Fixture/RghIn	11 /
Bed/F/H Bath	4 / 2.0 /
Basement Area	
Garage Type	482 Attached Garage - Unfinished
Remodel	
Year/Eff Age	2018 / 6



\\tsclient\T\LOGAN\LOGAN RESIDENTIAL VI\2023-6-28\IMG_003! 6/28/2023

GRM Approach	
GRM Code	
Gross Rent	0.00
Indicated Value	

Multiple Regression			
MRA Code	1	Test	
Adusted R	0.8445		
Indicated Value	263,246	135.97	Per SqFt

Direct Comparables	
Selection Model	A Adam Test
Adjustment Model	NewTest
Comparables	
Indicated Value	

Cost Approach				Manual : 01/2025			
Base Cost	105.69	Total Misc Impr	+	6,284			
Roofing Adj	+ 3.75	Garage Cost	+	19,391			
Subfloor Adj	+ -0.80	Total RCN	=	272,980			
Heat/Cool Adj	+ 11.69	Depreciation (6%)	-	16,379			
Plumbing Adj	+ 7.41	Lump Sums	+	0			
Basement Adj	+ 0.00	RCNLD	=	256,601			
Adj Base Cost	= 127.74	Lot Value	+	8,580			
Total Area	x 1,936	Indicated Value	=	265,181			
Adjusted Cost	= 247,305	Value Per SqFt		136.97			

Value Reconciliation			
Selected Approach	Cost Approach		
Improvements	256,601		
Lot Value	8,580		
Indicated Value	265,181	136.97	Per SqFt
Agland Value			
Site Improvements			
Total Value	265,181	136.97	Total Value Per SqFt

Miscellaneous Improvements								
Code	Description	Sketch ID	Size	Year	Units	Unit Cost	Depr	Value
PRCH	SLAB PORCH - COVERED	138243	11x5		55	26.18		1,440
PRCH	SLAB PORCH - COVERED	138244	11x5		55	26.18		1,440
PRCH	SLAB PORCH - COVERED	138245	13x5		65	26.18		1,702
PRCH	SLAB PORCH - COVERED	138246	13x5		65	26.18		1,702



Rogers

Assessment Property Record Card for Tax Year 2026

Data provided by LISA DELOZIER County Assessor

Date 04/18/2026

Time 09:31:11

Page 3

Sketch Image

660100350

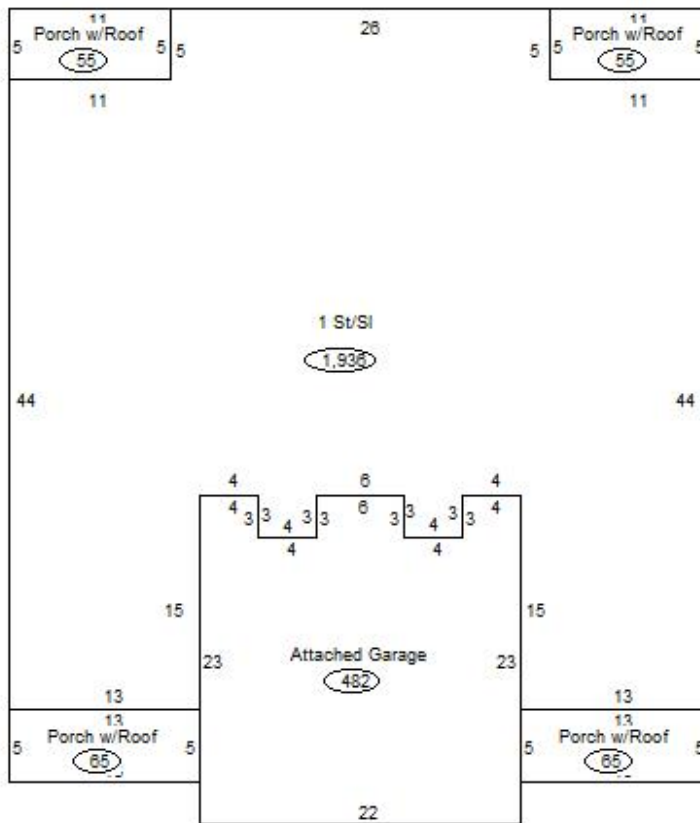

Sketch Vector Information

Sequence	Code	Type	Built Over	Scale	Section Label	Base Area	Multiplier	Total Area
1	R	1	Slab	13	1 St/Sl	1,936	1.000	1,936
2	G	1		13	Attached Garage	482	1.000	482
3	M	PRCH		13	SLBC	55	1.000	55
4	M	PRCH		13	SLBC	55	1.000	55
5	M	PRCH		13	SLBC	65	1.000	65
6	M	PRCH		13	SLBC	65	1.000	65
Total Building Area						1,936		1,936