



Rogers

Assessment Property Record Card for Tax Year 2026

Data provided by LISA DELOZIER County Assessor

Date 04/18/2026
 Time 09:34:05
 Page 1

Assessment Data					Primary Image																																																																												
Account 660100727 Parcel ID 00000000-00200248-001-0007 Cadastral ID 01-20-14-03260 Property Type REAL - Real Property Property Class RRP VI Area 3 Tax Area 3 - OWASSO RURAL/NO FIRE Name ID 332752 HYLANDER, SPENCER ALLEN & KATHRYN JEAN 18826 E CHOKEBERRY ST OWASSO OK 74055-0000 Parcel Location Situs 18826 E CHOKEBERRY ST Subdivision DEER RUN AT STONE CANYON PHASE II Lot/Block 0007 / 0001 Parcel Size 1 - Lots Sec/Twn/Rng 1 / 20 / 14 / 5 Neighborhood 1039 - R-V04, SW OWASSO School District S021 - OWASSO SCHOOLS					<p>\\tsclient\T\LOGAN\LOGAN RESIDENTIAL VI\2021-7-13\IMG_008 7/13/2021</p>																																																																												
Legal Description Lat/Long: 36.24449547 -95.76525623 LOT 7 BLOCK 1 DEER RUN AT STONE CANYON PHASE II																																																																																	
Exemptions <table border="1"> <thead> <tr> <th>Code</th> <th>Type</th> <th>Active</th> <th>Maximum</th> <th>Exemption</th> </tr> </thead> <tbody> <tr> <td>H</td> <td>Homestead</td> <td>Yes</td> <td>1,000</td> <td>1,000</td> </tr> </tbody> </table>					Code	Type	Active	Maximum	Exemption	H	Homestead	Yes	1,000	1,000	Building Permits <table border="1"> <thead> <tr> <th>Number</th> <th>Description</th> <th>Opened</th> <th>Closed</th> <th>Amount</th> </tr> </thead> <tbody> <tr> <td>R19 000439</td> <td>R21- NEW 2927 SQ FT SFR</td> <td>12/2019</td> <td>08/2020</td> <td>378,000</td> </tr> </tbody> </table>					Number	Description	Opened	Closed	Amount	R19 000439	R21- NEW 2927 SQ FT SFR	12/2019	08/2020	378,000																																																				
Code	Type	Active	Maximum	Exemption																																																																													
H	Homestead	Yes	1,000	1,000																																																																													
Number	Description	Opened	Closed	Amount																																																																													
R19 000439	R21- NEW 2927 SQ FT SFR	12/2019	08/2020	378,000																																																																													
Parcel Valuation <table border="1"> <thead> <tr> <th>Source</th> <th>REAL</th> <th>Fair Cash</th> <th>Capped</th> <th>Asmnt Level</th> <th>Assessed</th> <th>Levy Rate</th> <th>97.960</th> <th>Current Tax</th> </tr> </thead> <tbody> <tr> <td>Remove Cap</td> <td>2021</td> <td>Land Value</td> <td>124,580</td> <td>124,580</td> <td>11%</td> <td>13,704</td> <td>Assessed</td> <td>59,463 5,825.00</td> </tr> <tr> <td>Year Frozen</td> <td></td> <td>Improvements</td> <td>429,656</td> <td>415,988</td> <td></td> <td>45,759</td> <td>Penalty</td> <td>0</td> </tr> <tr> <td>Uncapped Value</td> <td>0</td> <td>Mobile Home</td> <td>0</td> <td>0</td> <td></td> <td>0</td> <td>Exemption</td> <td>1,000 -98.00</td> </tr> <tr> <td>TIF Project ID</td> <td>0</td> <td>Total Value</td> <td>554,236</td> <td>540,568</td> <td></td> <td>59,463</td> <td>Total Taxable</td> <td>58,463 5,727.00</td> </tr> </tbody> </table>					Source	REAL	Fair Cash	Capped	Asmnt Level	Assessed	Levy Rate	97.960	Current Tax	Remove Cap	2021	Land Value	124,580	124,580	11%	13,704	Assessed	59,463 5,825.00	Year Frozen		Improvements	429,656	415,988		45,759	Penalty	0	Uncapped Value	0	Mobile Home	0	0		0	Exemption	1,000 -98.00	TIF Project ID	0	Total Value	554,236	540,568		59,463	Total Taxable	58,463 5,727.00	Sale History <table border="1"> <thead> <tr> <th>Bk/Pg</th> <th>Grantor</th> <th>Date</th> <th>Price</th> <th>Code</th> </tr> </thead> <tbody> <tr> <td>/</td> <td>FOUR M HOME & PROPERTIES LLC</td> <td>11/05/2020</td> <td>485,000</td> <td>YES</td> </tr> <tr> <td>/</td> <td>C.A.B.O. DEVELOPMENT COMPANY LI</td> <td>12/12/2019</td> <td>75,500</td> <td>YES</td> </tr> </tbody> </table>					Bk/Pg	Grantor	Date	Price	Code	/	FOUR M HOME & PROPERTIES LLC	11/05/2020	485,000	YES	/	C.A.B.O. DEVELOPMENT COMPANY LI	12/12/2019	75,500	YES												
Source	REAL	Fair Cash	Capped	Asmnt Level	Assessed	Levy Rate	97.960	Current Tax																																																																									
Remove Cap	2021	Land Value	124,580	124,580	11%	13,704	Assessed	59,463 5,825.00																																																																									
Year Frozen		Improvements	429,656	415,988		45,759	Penalty	0																																																																									
Uncapped Value	0	Mobile Home	0	0		0	Exemption	1,000 -98.00																																																																									
TIF Project ID	0	Total Value	554,236	540,568		59,463	Total Taxable	58,463 5,727.00																																																																									
Bk/Pg	Grantor	Date	Price	Code																																																																													
/	FOUR M HOME & PROPERTIES LLC	11/05/2020	485,000	YES																																																																													
/	C.A.B.O. DEVELOPMENT COMPANY LI	12/12/2019	75,500	YES																																																																													
Assessment History <table border="1"> <thead> <tr> <th>Tax Year</th> <th>Statement Number</th> <th>Billed Owner</th> <th>Tax Area</th> <th>Total Value</th> <th>Exemptions</th> <th>Taxable Value</th> <th>Billed Tax</th> </tr> </thead> <tbody> <tr> <td>2025</td> <td>2025-660100727</td> <td>HYLANDER, SPENCER ALLEN &</td> <td>3</td> <td>524,824</td> <td>1000</td> <td>56,731</td> <td>5,557.00</td> </tr> <tr> <td>2024</td> <td>2024-660100727</td> <td>HYLANDER, SPENCER ALLEN &</td> <td>3</td> <td>591,276</td> <td>1000</td> <td>60,040</td> <td>5,768.00</td> </tr> <tr> <td>2023</td> <td>2023-660100727</td> <td>HYLANDER, SPENCER ALLEN &</td> <td>3</td> <td>561,964</td> <td>0</td> <td>59,262</td> <td>5,553.00</td> </tr> <tr> <td>2022</td> <td>2022-660100727</td> <td>HYLANDER, SPENCER ALLEN &</td> <td>3</td> <td>532,476</td> <td>0</td> <td>56,440</td> <td>5,529.00</td> </tr> <tr> <td>2021</td> <td>2021-660100727</td> <td>HYLANDER, SPENCER ALLEN &</td> <td>3</td> <td>485,649</td> <td>0</td> <td>53,421</td> <td>5,168.00</td> </tr> <tr> <td>2020</td> <td>2020-660100727</td> <td>FOUR M HOME & PROPERTIES LLC</td> <td>3</td> <td>76,500</td> <td>0</td> <td>8,415</td> <td>813.00</td> </tr> <tr> <td>2019</td> <td>2019-660100727</td> <td>C.A.B.O. DEVELOPMENT COMPANY LLC</td> <td>3</td> <td>5,691</td> <td>0</td> <td>626</td> <td>61.00</td> </tr> <tr> <td>2018</td> <td>2018-660100727</td> <td>C.A.B.O. DEVELOPMENT COMPANY LLC</td> <td>3</td> <td>5,691</td> <td>0</td> <td>626</td> <td>58.00</td> </tr> </tbody> </table>										Tax Year	Statement Number	Billed Owner	Tax Area	Total Value	Exemptions	Taxable Value	Billed Tax	2025	2025-660100727	HYLANDER, SPENCER ALLEN &	3	524,824	1000	56,731	5,557.00	2024	2024-660100727	HYLANDER, SPENCER ALLEN &	3	591,276	1000	60,040	5,768.00	2023	2023-660100727	HYLANDER, SPENCER ALLEN &	3	561,964	0	59,262	5,553.00	2022	2022-660100727	HYLANDER, SPENCER ALLEN &	3	532,476	0	56,440	5,529.00	2021	2021-660100727	HYLANDER, SPENCER ALLEN &	3	485,649	0	53,421	5,168.00	2020	2020-660100727	FOUR M HOME & PROPERTIES LLC	3	76,500	0	8,415	813.00	2019	2019-660100727	C.A.B.O. DEVELOPMENT COMPANY LLC	3	5,691	0	626	61.00	2018	2018-660100727	C.A.B.O. DEVELOPMENT COMPANY LLC	3	5,691	0	626	58.00
Tax Year	Statement Number	Billed Owner	Tax Area	Total Value	Exemptions	Taxable Value	Billed Tax																																																																										
2025	2025-660100727	HYLANDER, SPENCER ALLEN &	3	524,824	1000	56,731	5,557.00																																																																										
2024	2024-660100727	HYLANDER, SPENCER ALLEN &	3	591,276	1000	60,040	5,768.00																																																																										
2023	2023-660100727	HYLANDER, SPENCER ALLEN &	3	561,964	0	59,262	5,553.00																																																																										
2022	2022-660100727	HYLANDER, SPENCER ALLEN &	3	532,476	0	56,440	5,529.00																																																																										
2021	2021-660100727	HYLANDER, SPENCER ALLEN &	3	485,649	0	53,421	5,168.00																																																																										
2020	2020-660100727	FOUR M HOME & PROPERTIES LLC	3	76,500	0	8,415	813.00																																																																										
2019	2019-660100727	C.A.B.O. DEVELOPMENT COMPANY LLC	3	5,691	0	626	61.00																																																																										
2018	2018-660100727	C.A.B.O. DEVELOPMENT COMPANY LLC	3	5,691	0	626	58.00																																																																										



Rogers

Assessment Property Record Card for Tax Year 2026

Data provided by LISA DELOZIER County Assessor

Date 04/18/2026
 Time 09:34:05
 Page 2

Lot Data		Square-Foot - NBHD 1039 #1	
Lot Size	0	0	
Lot Count	1		
Units Buildable			
Non-Ag Acres	0.5647		
Topography			
Street Access			
Utilities			
Amenities			0
			0
Method	Square-Foot		
Base Lot Value	24,600.00 x 5.06 = 124,580		
Factor Value			
Adjustments	1.0000		
Lot Value	124,580		



\\tsclient\T\LOGAN\LOGAN RESIDENTIAL VI\2021-7-13\IMG_008 7/13/2021

Residential Data	
Type	1 Single Family Residence
Condition	5 - Very Good
Quality	4 - Good
Architecture	TRAD TRADITIONAL
Style	100% 1 1/2 Story Finished
Exterior Wall	85% Frame, Stucco 15% Veneer, Stone
Base/Total Area	2,005 / 2,938
Style	100% 1 1/2 Story Finished
HVAC	100% Warmed & Cooled Air
Roof Cover	1 Composition Shingle
Area on Slab	2,005
Fixture/RghIn	16 /
Bed/F/H Bath	4 / 3.0 /
Basement Area	
Garage Type	762 Attached Garage - Finished
Remodel	
Year/Eff Age	2020 / 3

GRM Approach	
GRM Code	
Gross Rent	0.00
Indicated Value	

Multiple Regression			
MRA Code	1	Test	
Adusted R	0.8445		
Indicated Value	439,006	149.42	Per SqFt

Direct Comparables			
Selection Model	A	Adam Test	
Adjustment Model	1	2022 Residential	
Comparables	6		
Indicated Value	568,770		Per SqFt

Cost Approach		Manual : 01/2025	
Base Cost	98.28	Total Misc Impr	+ 31,418
Roofing Adj	+ 4.13	Garage Cost	+ 43,365
Subfloor Adj	+ -3.15	Total RCN	= 442,944
Heat/Cool Adj	+ 16.31	Depreciation (3%)	- 13,288
Plumbing Adj	+ 9.74	Lump Sums	+ 0
Basement Adj	+ 0.00	RCNLD	= 429,656
Adj Base Cost	= 125.31	Lot Value	+ 124,580
Total Area	x 2,938	Indicated Value	= 554,236
Adjusted Cost	= 368,161	Value Per SqFt	188.64

Value Reconciliation			
Selected Approach	Cost Approach		
Improvements	429,656		
Lot Value	124,580		
Indicated Value	554,236	188.64	Per SqFt
Agland Value			
Site Improvements			
Total Value	554,236	188.64	Total Value Per SqFt

Miscellaneous Improvements								
Code	Description	Sketch ID	Size	Year	Units	Unit Cost	Depr	Value
FPR1	FIREPLACE - RESIDENTIAL 1 STORY	0		1	1	7,243.87		7,244
PRCH	SLAB PORCH - COVERED	146524	345		345	31.80		10,971
PRCH	SLAB PORCH - COVERED	146525	245		245	32.11		7,867
PATO	Slab Porch - Open	146527	495		495	10.78		5,336



Rogers
Assessment Property Record Card for Tax Year 2026

Data provided by LISA DELOZIER County Assessor

Date 04/18/2026
 Time 09:34:05
 Page 3

Sketch Image

660100727

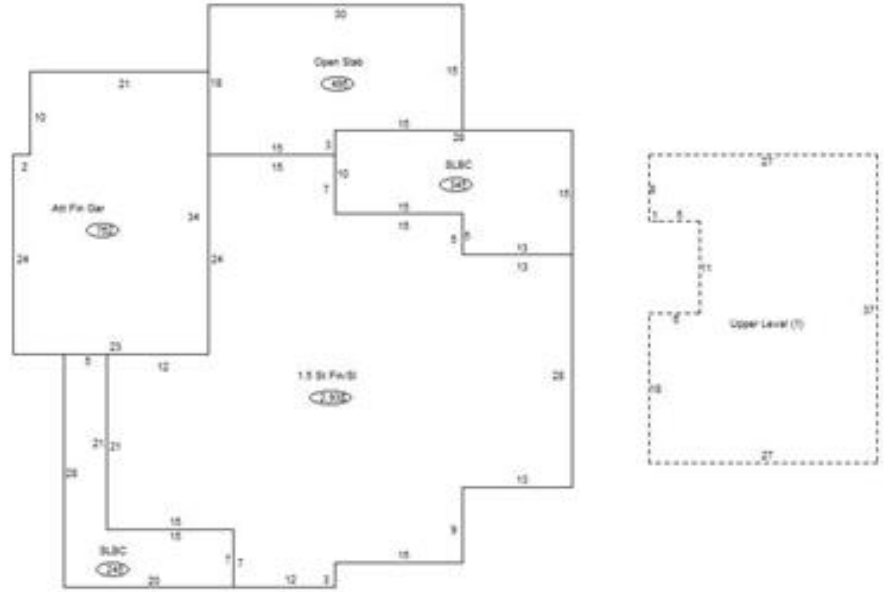

Sketch Vector Information

Sequence	Code	Type	Built Over	Scale	Section Label	Base Area	Multiplier	Total Area
1	R	5	Slab	13	1.5 St Fin/SI	2,005	1.465	2,938
2	G	5		13	Att Fin Gar	762	1.000	762
3	M	PRCH		13	SLBC	345	1.000	345
4	M	PRCH		13	SLBC	245	1.000	245
5	U	^UL		13	Upper Level (1)	933	1.000	933
6	M	PATO		13	Open Slab	495	1.000	495
Total Building Area						2,005		2,938