



Rogers

Assessment Property Record Card for Tax Year 2026

Data provided by LISA DELOZIER County Assessor

Date 04/18/2026
Time 09:35:15
Page 1

| Assessment Data | | | | | Primary Image | | | | | | | | | | | | | | | | | | | | | | | | | | | | | | | | | | | | | | | | | | | | | | | | | | | | | | | | | | | | | | | | | | | | | | | |
|---|---------------------------------|----------------------------------|----------|-------------|---------------|------------------|---------------|-------------|-------------|------------|-----------------------------|------------|-------------|----------------|-----------------------------|---------------------|------------|---------|--------|----------|---------------------------------|----------------|-----------------------------|----|--------------|---------|---------|----------|--------|----------------|-----------------------------|----------------|---------|-------------|--------|----------|------|----------------|-----------------------------|----|----------------|---|-------------|----------|---------|----------------|-----------------------------|---------------|---------|---|--------|----------|------|----------------|---------------------|----|--------|----------|-------|--------|------|----------------|---------------------|----|-------|---|-----|-------|------|----------------|----------------------------------|----|-------|---|-----|-------|
| Account | 660100766 | | | | | | | | | | | | | | | | | | | | | | | | | | | | | | | | | | | | | | | | | | | | | | | | | | | | | | | | | | | | | | | | | | | | | | | | | | | |
| Parcel ID | 000000000-0000248-004-0001 | | | | | | | | | | | | | | | | | | | | | | | | | | | | | | | | | | | | | | | | | | | | | | | | | | | | | | | | | | | | | | | | | | | | | | | | | | | |
| Cadastral ID | 06-20-15-02200 | | | | | | | | | | | | | | | | | | | | | | | | | | | | | | | | | | | | | | | | | | | | | | | | | | | | | | | | | | | | | | | | | | | | | | | | | | | |
| Property Type | REAL - Real Property | | | | | | | | | | | | | | | | | | | | | | | | | | | | | | | | | | | | | | | | | | | | | | | | | | | | | | | | | | | | | | | | | | | | | | | | | | | |
| Property Class | RRP | VI Area | 3 | | | | | | | | | | | | | | | | | | | | | | | | | | | | | | | | | | | | | | | | | | | | | | | | | | | | | | | | | | | | | | | | | | | | | | | | | |
| Tax Area | 20 - CATOOSA RURAL | | | | | | | | | | | | | | | | | | | | | | | | | | | | | | | | | | | | | | | | | | | | | | | | | | | | | | | | | | | | | | | | | | | | | | | | | | | |
| Name ID | 333254 | | | | | | | | | | | | | | | | | | | | | | | | | | | | | | | | | | | | | | | | | | | | | | | | | | | | | | | | | | | | | | | | | | | | | | | | | | | |
| REAL PROPERTY INVESTORS LLC | | | | | | | | | | | | | | | | | | | | | | | | | | | | | | | | | | | | | | | | | | | | | | | | | | | | | | | | | | | | | | | | | | | | | | | | | | | | |
| 6270 N CREEKWOOD DR OWASSO OK 74055-0000 | | | | | | | | | | | | | | | | | | | | | | | | | | | | | | | | | | | | | | | | | | | | | | | | | | | | | | | | | | | | | | | | | | | | | | | | | | | | |
| Parcel Location Situs 06270 N CREEKWOOD DR Subdivision DEER RUN AT STONE CANYON PHASE II Lot/Block 0001 / 0004 Parcel Size 1 - Lots Sec/Twn/Rng 6 / 20 / 15 / 5 Neighborhood 1039 - R-V04, SW OWASSO School District S002 - CATOOSA SCHOOLS | | | | | | | | | | | | | | | | | | | | | | | | | | | | | | | | | | | | | | | | | | | | | | | | | | | | | | | | | | | | | | | | | | | | | | | | | | | | |
| Legal Description Lat/Long: 36.24448933 -95.75954960 | | | | | | | | | | | | | | | | | | | | | | | | | | | | | | | | | | | | | | | | | | | | | | | | | | | | | | | | | | | | | | | | | | | | | | | | | | | | |
| Building Permits <table border="1"> <thead> <tr> <th>Number</th> <th>Description</th> <th>Opened</th> <th>Closed</th> <th>Amount</th> </tr> </thead> <tbody> <tr> <td>R19</td> <td>R21- NEW 911 ADDRESS ASSGND</td> <td>10/2019</td> <td>10/2020</td> <td></td> </tr> </tbody> </table> | | | | | Number | Description | Opened | Closed | Amount | R19 | R21- NEW 911 ADDRESS ASSGND | 10/2019 | 10/2020 | | | | | | | | | | | | | | | | | | | | | | | | | | | | | | | | | | | | | | | | | | | | | | | | | | | | | | | | | | | | | | | |
| Number | Description | Opened | Closed | Amount | | | | | | | | | | | | | | | | | | | | | | | | | | | | | | | | | | | | | | | | | | | | | | | | | | | | | | | | | | | | | | | | | | | | | | | | |
| R19 | R21- NEW 911 ADDRESS ASSGND | 10/2019 | 10/2020 | | | | | | | | | | | | | | | | | | | | | | | | | | | | | | | | | | | | | | | | | | | | | | | | | | | | | | | | | | | | | | | | | | | | | | | | | |
| Exemptions <table border="1"> <thead> <tr> <th>Code</th> <th>Type</th> <th>Active</th> <th>Maximum</th> <th>Exemption</th> </tr> </thead> <tbody> <tr> <td></td> <td></td> <td></td> <td></td> <td></td> </tr> </tbody> </table> | | | | | Code | Type | Active | Maximum | Exemption | | | | | | | | | | | | | | | | | | | | | | | | | | | | | | | | | | | | | | | | | | | | | | | | | | | | | | | | | | | | | | | | | | | |
| Code | Type | Active | Maximum | Exemption | | | | | | | | | | | | | | | | | | | | | | | | | | | | | | | | | | | | | | | | | | | | | | | | | | | | | | | | | | | | | | | | | | | | | | | | |
| | | | | | | | | | | | | | | | | | | | | | | | | | | | | | | | | | | | | | | | | | | | | | | | | | | | | | | | | | | | | | | | | | | | | | | | | | | | | |
| Sale History <table border="1"> <thead> <tr> <th>Bk/Pg</th> <th>Grantor</th> <th>Date</th> <th>Price</th> <th>Code</th> </tr> </thead> <tbody> <tr> <td>/</td> <td>BALL, STEVEN R & MARCI K</td> <td>01/08/2021</td> <td>0</td> <td>4</td> </tr> <tr> <td>/</td> <td>EXECUTIVE HOMES LLC</td> <td>12/02/2020</td> <td>464,500</td> <td>YES</td> </tr> <tr> <td>/</td> <td>C.A.B.O. DEVELOPMENT COMPANY LI</td> <td>04/30/2019</td> <td>74,500</td> <td>15</td> </tr> </tbody> </table> | | | | | Bk/Pg | Grantor | Date | Price | Code | / | BALL, STEVEN R & MARCI K | 01/08/2021 | 0 | 4 | / | EXECUTIVE HOMES LLC | 12/02/2020 | 464,500 | YES | / | C.A.B.O. DEVELOPMENT COMPANY LI | 04/30/2019 | 74,500 | 15 | | | | | | | | | | | | | | | | | | | | | | | | | | | | | | | | | | | | | | | | | | | | | | | | | | | | |
| Bk/Pg | Grantor | Date | Price | Code | | | | | | | | | | | | | | | | | | | | | | | | | | | | | | | | | | | | | | | | | | | | | | | | | | | | | | | | | | | | | | | | | | | | | | | | |
| / | BALL, STEVEN R & MARCI K | 01/08/2021 | 0 | 4 | | | | | | | | | | | | | | | | | | | | | | | | | | | | | | | | | | | | | | | | | | | | | | | | | | | | | | | | | | | | | | | | | | | | | | | | |
| / | EXECUTIVE HOMES LLC | 12/02/2020 | 464,500 | YES | | | | | | | | | | | | | | | | | | | | | | | | | | | | | | | | | | | | | | | | | | | | | | | | | | | | | | | | | | | | | | | | | | | | | | | | |
| / | C.A.B.O. DEVELOPMENT COMPANY LI | 04/30/2019 | 74,500 | 15 | | | | | | | | | | | | | | | | | | | | | | | | | | | | | | | | | | | | | | | | | | | | | | | | | | | | | | | | | | | | | | | | | | | | | | | | |
| Parcel Valuation <table border="1"> <thead> <tr> <th>Source</th> <th>REAL</th> <th>Fair Cash</th> <th>Capped</th> <th>Asmnt Level</th> <th>Assessed</th> <th>Levy Rate</th> <th>92.860</th> <th>Current Tax</th> </tr> </thead> <tbody> <tr> <td>Remove Cap</td> <td>2021</td> <td>Land Value</td> <td>125,640</td> <td>125,640</td> <td>11%</td> <td>13,820</td> <td>Assessed</td> <td>64,695</td> </tr> <tr> <td>Year Frozen</td> <td></td> <td>Improvements</td> <td>470,686</td> <td>462,503</td> <td></td> <td>50,875</td> <td>Penalty</td> <td>0</td> </tr> <tr> <td>Uncapped Value</td> <td>0</td> <td>Mobile Home</td> <td>0</td> <td>0</td> <td></td> <td>0</td> <td>Exemption</td> <td>0</td> </tr> <tr> <td>TIF Project ID</td> <td>0</td> <td>Total Value</td> <td>596,326</td> <td>588,143</td> <td></td> <td>64,695</td> <td>Total Taxable</td> <td>64,695</td> </tr> <tr> <td></td> <td></td> <td></td> <td></td> <td></td> <td></td> <td></td> <td></td> <td>6,008.00</td> </tr> </tbody> </table> | | | | | Source | REAL | Fair Cash | Capped | Asmnt Level | Assessed | Levy Rate | 92.860 | Current Tax | Remove Cap | 2021 | Land Value | 125,640 | 125,640 | 11% | 13,820 | Assessed | 64,695 | Year Frozen | | Improvements | 470,686 | 462,503 | | 50,875 | Penalty | 0 | Uncapped Value | 0 | Mobile Home | 0 | 0 | | 0 | Exemption | 0 | TIF Project ID | 0 | Total Value | 596,326 | 588,143 | | 64,695 | Total Taxable | 64,695 | | | | | | | | | 6,008.00 | | | | | | | | | | | | | | | | | | |
| Source | REAL | Fair Cash | Capped | Asmnt Level | Assessed | Levy Rate | 92.860 | Current Tax | | | | | | | | | | | | | | | | | | | | | | | | | | | | | | | | | | | | | | | | | | | | | | | | | | | | | | | | | | | | | | | | | | | | |
| Remove Cap | 2021 | Land Value | 125,640 | 125,640 | 11% | 13,820 | Assessed | 64,695 | | | | | | | | | | | | | | | | | | | | | | | | | | | | | | | | | | | | | | | | | | | | | | | | | | | | | | | | | | | | | | | | | | | | |
| Year Frozen | | Improvements | 470,686 | 462,503 | | 50,875 | Penalty | 0 | | | | | | | | | | | | | | | | | | | | | | | | | | | | | | | | | | | | | | | | | | | | | | | | | | | | | | | | | | | | | | | | | | | | |
| Uncapped Value | 0 | Mobile Home | 0 | 0 | | 0 | Exemption | 0 | | | | | | | | | | | | | | | | | | | | | | | | | | | | | | | | | | | | | | | | | | | | | | | | | | | | | | | | | | | | | | | | | | | | |
| TIF Project ID | 0 | Total Value | 596,326 | 588,143 | | 64,695 | Total Taxable | 64,695 | | | | | | | | | | | | | | | | | | | | | | | | | | | | | | | | | | | | | | | | | | | | | | | | | | | | | | | | | | | | | | | | | | | | |
| | | | | | | | | 6,008.00 | | | | | | | | | | | | | | | | | | | | | | | | | | | | | | | | | | | | | | | | | | | | | | | | | | | | | | | | | | | | | | | | | | | | |
| Assessment History <table border="1"> <thead> <tr> <th>Tax Year</th> <th>Statement Number</th> <th>Billed Owner</th> <th>Tax Area</th> <th>Total Value</th> <th>Exemptions</th> <th>Taxable Value</th> <th>Billed Tax</th> </tr> </thead> <tbody> <tr> <td>2025</td> <td>2025-660100766</td> <td>REAL PROPERTY INVESTORS LLC</td> <td>20</td> <td>563,525</td> <td>0</td> <td>61,615</td> <td>5,722.00</td> </tr> <tr> <td>2024</td> <td>2024-660100766</td> <td>REAL PROPERTY INVESTORS LLC</td> <td>20</td> <td>557,467</td> <td>0</td> <td>58,681</td> <td>5,308.00</td> </tr> <tr> <td>2023</td> <td>2023-660100766</td> <td>REAL PROPERTY INVESTORS LLC</td> <td>20</td> <td>510,701</td> <td>0</td> <td>55,887</td> <td>4,852.00</td> </tr> <tr> <td>2022</td> <td>2022-660100766</td> <td>REAL PROPERTY INVESTORS LLC</td> <td>20</td> <td>483,868</td> <td>0</td> <td>53,225</td> <td>4,633.00</td> </tr> <tr> <td>2021</td> <td>2021-660100766</td> <td>REAL PROPERTY INVESTORS LLC</td> <td>20</td> <td>465,201</td> <td>0</td> <td>51,172</td> <td>4,502.00</td> </tr> <tr> <td>2020</td> <td>2020-660100766</td> <td>EXECUTIVE HOMES LLC</td> <td>20</td> <td>76,500</td> <td>0</td> <td>8,415</td> <td>745.00</td> </tr> <tr> <td>2019</td> <td>2019-660100766</td> <td>EXECUTIVE HOMES LLC</td> <td>20</td> <td>5,691</td> <td>0</td> <td>626</td> <td>56.00</td> </tr> <tr> <td>2018</td> <td>2018-660100766</td> <td>C.A.B.O. DEVELOPMENT COMPANY LLC</td> <td>20</td> <td>5,691</td> <td>0</td> <td>626</td> <td>56.00</td> </tr> </tbody> </table> | | | | | Tax Year | Statement Number | Billed Owner | Tax Area | Total Value | Exemptions | Taxable Value | Billed Tax | 2025 | 2025-660100766 | REAL PROPERTY INVESTORS LLC | 20 | 563,525 | 0 | 61,615 | 5,722.00 | 2024 | 2024-660100766 | REAL PROPERTY INVESTORS LLC | 20 | 557,467 | 0 | 58,681 | 5,308.00 | 2023 | 2023-660100766 | REAL PROPERTY INVESTORS LLC | 20 | 510,701 | 0 | 55,887 | 4,852.00 | 2022 | 2022-660100766 | REAL PROPERTY INVESTORS LLC | 20 | 483,868 | 0 | 53,225 | 4,633.00 | 2021 | 2021-660100766 | REAL PROPERTY INVESTORS LLC | 20 | 465,201 | 0 | 51,172 | 4,502.00 | 2020 | 2020-660100766 | EXECUTIVE HOMES LLC | 20 | 76,500 | 0 | 8,415 | 745.00 | 2019 | 2019-660100766 | EXECUTIVE HOMES LLC | 20 | 5,691 | 0 | 626 | 56.00 | 2018 | 2018-660100766 | C.A.B.O. DEVELOPMENT COMPANY LLC | 20 | 5,691 | 0 | 626 | 56.00 |
| Tax Year | Statement Number | Billed Owner | Tax Area | Total Value | Exemptions | Taxable Value | Billed Tax | | | | | | | | | | | | | | | | | | | | | | | | | | | | | | | | | | | | | | | | | | | | | | | | | | | | | | | | | | | | | | | | | | | | | |
| 2025 | 2025-660100766 | REAL PROPERTY INVESTORS LLC | 20 | 563,525 | 0 | 61,615 | 5,722.00 | | | | | | | | | | | | | | | | | | | | | | | | | | | | | | | | | | | | | | | | | | | | | | | | | | | | | | | | | | | | | | | | | | | | | |
| 2024 | 2024-660100766 | REAL PROPERTY INVESTORS LLC | 20 | 557,467 | 0 | 58,681 | 5,308.00 | | | | | | | | | | | | | | | | | | | | | | | | | | | | | | | | | | | | | | | | | | | | | | | | | | | | | | | | | | | | | | | | | | | | | |
| 2023 | 2023-660100766 | REAL PROPERTY INVESTORS LLC | 20 | 510,701 | 0 | 55,887 | 4,852.00 | | | | | | | | | | | | | | | | | | | | | | | | | | | | | | | | | | | | | | | | | | | | | | | | | | | | | | | | | | | | | | | | | | | | | |
| 2022 | 2022-660100766 | REAL PROPERTY INVESTORS LLC | 20 | 483,868 | 0 | 53,225 | 4,633.00 | | | | | | | | | | | | | | | | | | | | | | | | | | | | | | | | | | | | | | | | | | | | | | | | | | | | | | | | | | | | | | | | | | | | | |
| 2021 | 2021-660100766 | REAL PROPERTY INVESTORS LLC | 20 | 465,201 | 0 | 51,172 | 4,502.00 | | | | | | | | | | | | | | | | | | | | | | | | | | | | | | | | | | | | | | | | | | | | | | | | | | | | | | | | | | | | | | | | | | | | | |
| 2020 | 2020-660100766 | EXECUTIVE HOMES LLC | 20 | 76,500 | 0 | 8,415 | 745.00 | | | | | | | | | | | | | | | | | | | | | | | | | | | | | | | | | | | | | | | | | | | | | | | | | | | | | | | | | | | | | | | | | | | | | |
| 2019 | 2019-660100766 | EXECUTIVE HOMES LLC | 20 | 5,691 | 0 | 626 | 56.00 | | | | | | | | | | | | | | | | | | | | | | | | | | | | | | | | | | | | | | | | | | | | | | | | | | | | | | | | | | | | | | | | | | | | | |
| 2018 | 2018-660100766 | C.A.B.O. DEVELOPMENT COMPANY LLC | 20 | 5,691 | 0 | 626 | 56.00 | | | | | | | | | | | | | | | | | | | | | | | | | | | | | | | | | | | | | | | | | | | | | | | | | | | | | | | | | | | | | | | | | | | | | |



Rogers

Assessment Property Record Card for Tax Year 2026

Data provided by LISA DELOZIER County Assessor

Date 04/18/2026
Time 09:35:16
Page 2

| Lot Data | Square-Foot - NBHD 1039 #1 | Primary Image |
|-----------------|----------------------------|---------------|
| Lot Size | 0 0 | |
| Lot Count | 1 | |
| Units Buildable | | |
| Non-Ag Acres | 0.5753 | |
| Topography | | |
| Street Access | | |
| Utilities | | |
| Amenities | 0 | |
| | 0 | |
| Method | Square-Foot | |
| Base Lot Value | 25,061.00 x 5.01 = 125,640 | |
| Factor Value | | |
| Adjustments | 1.0000 | |
| Lot Value | 125,640 | |

| Residential Data | |
|------------------|---|
| Type | 1 Single Family Residence |
| Condition | 4 - Good |
| Quality | 4 - Good |
| Architecture | TRAD TRADITIONAL |
| Style | 100% One Story |
| Exterior Wall | 100% Veneer, Masonry |
| Base/Total Area | 3,066 / 3,066 |
| Style | 100% One Story |
| HVAC | 100% Warmed & Cooled Air |
| Roof Cover | 1 Composition Shingle |
| Area on Slab | 3,066 |
| Fixture/RghIn | 20 / |
| Bed/F/H Bath | 4 / 3.0 / 1.0 |
| Basement Area | |
| Garage Type | 701 Attached Garage - Finished 3 Stalls |
| Remodel | |
| Year/Eff Age | 2020 / 4 |



660100766_001.JPG 10/7/2025

| GRM Approach | |
|-----------------|------|
| GRM Code | |
| Gross Rent | 0.00 |
| Indicated Value | |

| Multiple Regression | | | |
|---------------------|---------|--------|----------|
| MRA Code | 1 | Test | |
| Adusted R | 0.8445 | | |
| Indicated Value | 446,118 | 145.50 | Per SqFt |

| Direct Comparables | | | |
|--------------------|---------|------------------|----------|
| Selection Model | A | Adam Test | |
| Adjustment Model | 1 | 2022 Residential | |
| Comparables | 6 | | |
| Indicated Value | 530,670 | | Per SqFt |

| Cost Approach | | | | Manual : 01/2025 | | | |
|---------------|-----------|--------------------|---|------------------|--|--|--|
| Base Cost | 108.90 | Total Misc Impr | + | 26,876 | | | |
| Roofing Adj | + 5.62 | Garage Cost | + | 40,069 | | | |
| Subfloor Adj | + -4.35 | Total RCN | = | 490,298 | | | |
| Heat/Cool Adj | + 16.31 | Depreciation (4%) | - | 19,612 | | | |
| Plumbing Adj | + 11.60 | Lump Sums | + | 0 | | | |
| Basement Adj | + 0.00 | RCNLD | = | 470,686 | | | |
| Adj Base Cost | = 138.08 | Lot Value | + | 125,640 | | | |
| Total Area | x 3,066 | Indicated Value | = | 596,326 | | | |
| Adjusted Cost | = 423,353 | Value Per SqFt | | 194.50 | | | |

| Value Reconciliation | | | |
|----------------------|---------------|--------|----------------------|
| Selected Approach | Cost Approach | | |
| Improvements | 470,686 | | |
| Lot Value | 125,640 | | |
| Indicated Value | 596,326 | 194.50 | Per SqFt |
| Agland Value | | | |
| Site Improvements | | | |
| Total Value | 596,326 | 194.50 | Total Value Per SqFt |

| Miscellaneous Improvements | | | | | | | | |
|----------------------------|---------------------------------|-----------|------|------|-------|-----------|------|--------|
| Code | Description | Sketch ID | Size | Year | Units | Unit Cost | Depr | Value |
| FPR1 | FIREPLACE - RESIDENTIAL 1 STORY | 0 | | 1 | 1 | 7,243.87 | | 7,244 |
| PRCH | SLAB PORCH - COVERED | 147355 | 572 | | 572 | 31.09 | | 17,783 |
| PRCH | SLAB PORCH - COVERED | 147680 | 56 | | 56 | 33.02 | | 1,849 |



Rogers

Assessment Property Record Card for Tax Year 2026

Data provided by LISA DELOZIER County Assessor

Date 04/18/2026
 Time 09:35:16
 Page 3

Sketch Image

660100766

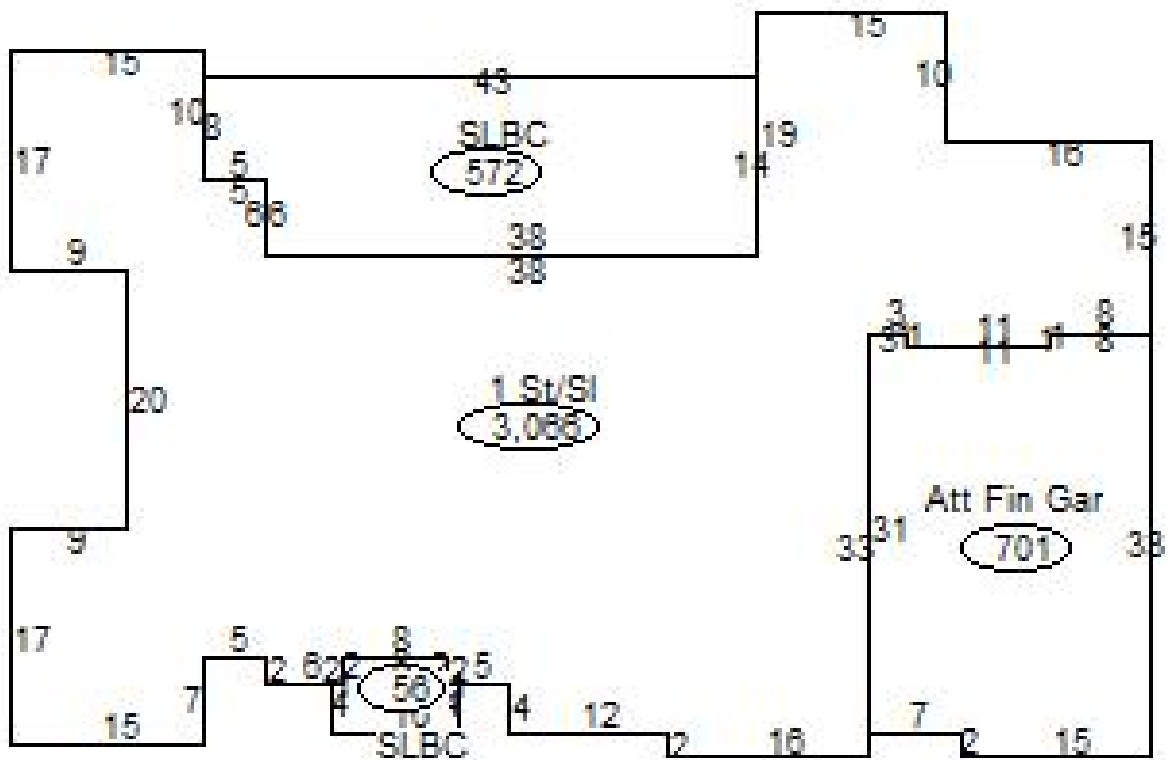

Sketch Vector Information

| Sequence | Code | Type | Built Over | Scale | Section Label | Base Area | Multiplier | Total Area |
|----------------------------|------|------|------------|-------|---------------|--------------|------------|--------------|
| 1 | R | 1 | Slab | 30 | 1 St/SI | 3,066 | 1.000 | 3,066 |
| 2 | G | 5 | | 30 | Att Fin Gar | 701 | 1.000 | 701 |
| 3 | M | PRCH | | 30 | SLBC | 572 | 1.000 | 572 |
| 4 | M | PRCH | | 30 | SLBC | 56 | 1.000 | 56 |
| Total Building Area | | | | | | 3,066 | | 3,066 |