



Rogers

Assessment Property Record Card for Tax Year 2026

Data provided by LISA DELOZIER County Assessor

Date 04/18/2026
Time 09:42:36
Page 1

Assessment Data				Primary Image					
Account	660101385			<p>\\tsclient\T\ROB STUFF\2022-9-26\IMG_0001.JPG 9/26/2022</p>					
Parcel ID	000000000-1010196-015-0012								
Cadastral ID	27-21-14-06210								
Property Type	REAL - Real Property								
Property Class	RRP	VI Area	4						
Tax Area	3 - OWASSO RURAL/NO FIRE								
Name ID	335844								
LOYD, HANK & MOLLY									
15028 E 82ND ST N OWASSO OK 74055-0000									
Parcel Location									
Situs	15028 E 82ND ST N								
Subdivision	HOMESTEAD								
Lot/Block	0012 / 0015	Parcel Size	1 - Lots						
Sec/Twn/Rng	27 / 21 / 14 / 5								
Neighborhood	1011 - R-V04 SW OWASSO								
School District	S021 - OWASSO SCHOOLS								
Legal Description Lat/Long: 36.27157372 -95.80516620				Building Permits					
LOT 12 BLOCK 15 HOMESTEAD				Number	Description	Opened	Closed	Amount	
				R21	R23- POSS NEW SFR PER MRTGE	09/2021	09/2022	412,000	
Exemptions				Sale History					
Code	Type	Active	Maximum	Exemption	Bk/Pg	Grantor	Date	Price	Code
					/	1ST CHOICE QUALITY BUILDERS LLC	09/21/2021	103,500	YES
					/	SOC'S DEVELOPMENT LLC	12/10/2019	76,500	15
Parcel Valuation									
Source	REAL		Fair Cash	Capped	Asmnt Level	Assessed	Levy Rate	97.960	Current Tax
Remove Cap	2022		Land Value	76,623	76,623	11%	Assessed	13,180	1,291.11
Year Frozen			Improvements	505,592	43,190		Penalty	0	
Uncapped Value	0		Mobile Home	0	0		Exemption	0	0.00
TIF Project ID	0		Total Value	582,215	119,813		Total Taxable	13,180	1,291.00
Assessment History									
Tax Year	Statement Number	Billed Owner			Tax Area	Total Value	Exemptions	Taxable Value	Billed Tax
2025	2025-660101385	LOYD, HANK & MOLLY			3	554,835	0	12,552	1,230.00
2024	2024-660101385	LOYD, HANK & MOLLY			3	657,018	0	11,954	1,148.00
2023	2023-660101385	LOYD, HANK & MOLLY			3	103,500	0	11,385	1,067.00
2022	2022-660101385	LOYD, HANK & MOLLY			3	103,500	0	11,385	1,115.00
2021	2021-660101385	LOYD, HANK & MOLLY			3	77,625	0	8,539	826.00
2020	2020-660101385	1ST CHOICE QUALITY BUILDERS LLC			3	77,625	0	8,539	825.00
2019	2019-660101385	SOC'S DEVELOPMENT LLC			3	863	0	95	9.00



Rogers

Assessment Property Record Card for Tax Year 2026

Data provided by LISA DELOZIER County Assessor

Date 04/18/2026
Time 09:42:36
Page 2

Lot Data		Square-Foot - NBHD 1011 #1	
Lot Size	0	0	
Lot Count	1		
Units Buildable			
Non-Ag Acres	0.6515		
Topography			
Street Access			
Utilities			
Amenities	LAND QUALITY		0
			0
Method	Square-Foot		
Base Lot Value	28,379.00 x 2.70 = 76,623		
Factor Value			
Adjustments	1.0000		
Lot Value	76,623		



\\tsclient\T\ROB STUFF\2022-9-26\IMG_0001.JPG 9/26/2022

Residential Data	
Type	1 Single Family Residence
Condition	3 - Average
Quality	4 - Good
Architecture	
Style	100% One Story
Exterior Wall	80% Veneer, Masonry 20% Veneer, Stone
Base/Total Area	3,285 / 3,285
Style	100% One Story
HVAC	100% Warmed & Cooled Air
Roof Cover	1 Composition Shingle
Area on Slab	3,285
Fixture/RghIn	/
Bed/F/H Bath	5 / 3.0 / 1.0
Basement Area	
Garage Type	876 Attached Garage - Finished
Remodel	
Year/Eff Age	2022 / 3

GRM Approach

GRM Code	
Gross Rent	0.00
Indicated Value	

Multiple Regression

MRA Code	1	Test
Adjusted R	0.8445	
Indicated Value	489,043	148.87 Per SqFt

Direct Comparables

Selection Model	A	Adam Test
Adjustment Model	1	2022 Residential
Comparables	1	
Indicated Value	428,860	Per SqFt

Value Reconciliation

Selected Approach	Cost Approach		
Improvements	505,592		
Lot Value	76,623		
Indicated Value	582,215	177.23	Per SqFt
Agland Value			
Site Improvements			
Total Value	582,215	177.23	Total Value Per SqFt

Cost Approach		Manual : 01/2025	
Base Cost	108.78	Total Misc Impr	+ 32,763
Roofing Adj	+ 5.59	Garage Cost	+ 49,853
Subfloor Adj	+ -4.29	Total RCN	= 521,229
Heat/Cool Adj	+ 16.31	Depreciation (3%)	- 15,637
Plumbing Adj	+ 7.13	Lump Sums	+ 0
Basement Adj	+ 0.00	RCNLD	= 505,592
Adj Base Cost	= 133.52	Lot Value	+ 76,623
Total Area	x 3,285	Indicated Value	= 582,215
Adjusted Cost	= 438,613	Value Per SqFt	177.23

Miscellaneous Improvements

Code	Description	Sketch ID	Size	Year	Units	Unit Cost	Depr	Value
PRCH	Slab Porch - Covered	155258	34x7		238	32.13		7,647
PRCH	Slab Porch - Covered	155259	21x14		294	31.96		9,396
PATO	Slab Porch - Open	155260	13x7		91	14.39		1,309
PRCH	Slab Porch - Covered	155261	24x10		240	32.13		7,711
FPPF	Fireplace - Prefabricated			1	1	6,700.26		6,700



Rogers

Assessment Property Record Card for Tax Year 2026

Data provided by LISA DELOZIER County Assessor

Date 04/18/2026

Time 09:42:36

Page 3

Sketch Image

660101385

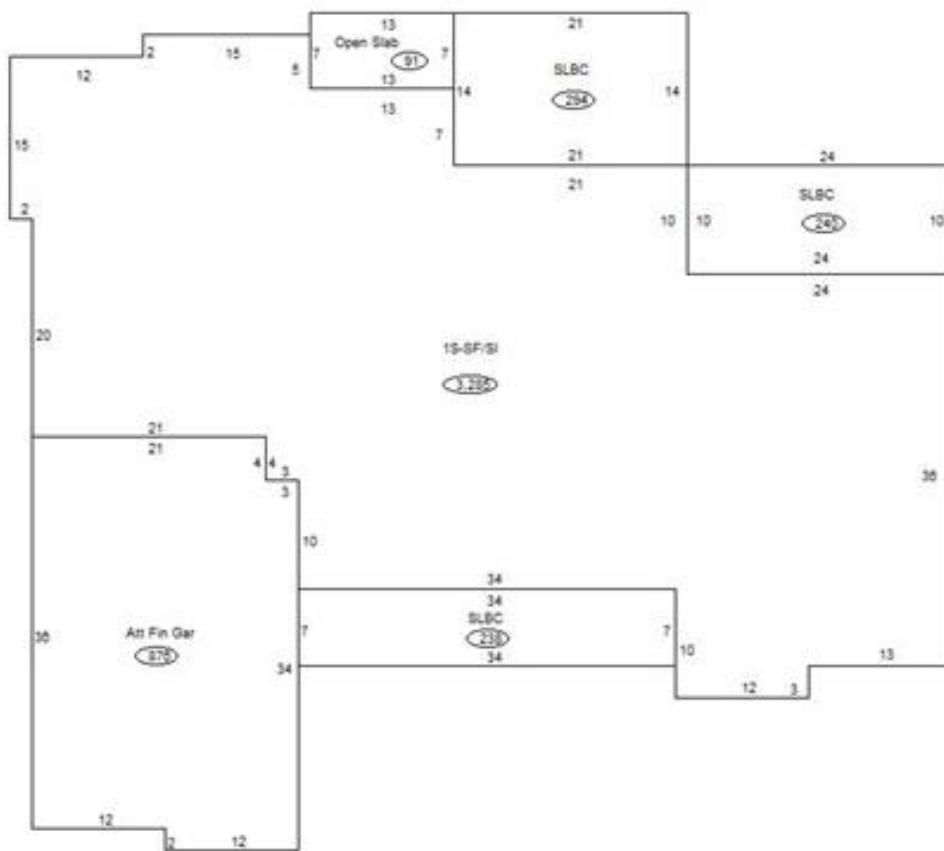

Sketch Vector Information

Sequence	Code	Type	Built Over	Scale	Section Label	Base Area	Multiplier	Total Area
1	R	1	Slab	13	1S-SF/SI	3,285	1.000	3,285
2	G	5		13	Att Fin Gar	876	1.000	876
3	M	PRCH		13	SLBC	238	1.000	238
4	M	PRCH		13	SLBC	294	1.000	294
5	M	PATO		13	Open Slab	91	1.000	91
6	M	PRCH		13	SLBC	240	1.000	240
Total Building Area						3,285		3,285