



Rogers

Assessment Property Record Card for Tax Year 2026

Data provided by LISA DELOZIER County Assessor

Date 04/18/2026
Time 10:04:47
Page 1

Assessment Data					Primary Image				
Account	660103495				<p>\\tsclient\X\Rob Stuff\ROBS NEW CONST\2022-9-1\IMG_0001.JPG 9/1/2022</p>				
Parcel ID	21N15E-25-2-00000-005-0000								
Cadastral ID	25-21-15-00214								
Property Type	REAL - Real Property								
Property Class	RA	VI Area	4						
Tax Area	4 - VERDIGRIS/VERD FIRE								
Name ID	328783								
JONES, ERIN & JAY									
23435 S 4120 RD CLAREMORE OK 74019-0000									
Parcel Location									
Situs	23435 S 4120 RD								
Subdivision									
Lot/Block	/	Parcel Size	4.95 - Acres						
Sec/Twn/Rng	25 / 21 / 15 / 2								
Neighborhood	6090 - UNPLATTED								
School District	S008 - VERDIGRIS SCHOOLS								
Legal Description Lat/Long: 36.27161323 -95.66538355									
TR DESC 2020-018365 AS BEG SW/C S2 SW NW; S88.3825W 656.42'; N01.1715W 164.24'; N88.3755E 43'; N01.1715W 154.24'; S88.3725W 706 27'; N01.1715W 10'; N88.3725E 1319.76'; S01.1628E 328.66' TO POB.									
Building Permits									
Number		Description		Opened	Closed	Amount			
R21	R23			12/2019	09/2022				
Exemptions									
Code	Type	Active	Maximum	Exemption	Sale History				
H	Homestead	Yes	1,000	1,000	Bk/Pg	Grantor	Date	Price	Code
					/	JONES, ERIN & JAY	11/19/2020	0	4
Parcel Valuation									
Source	REAL	Fair Cash	Capped	Asmnt Level	Assessed	Levy Rate	104.132	Current Tax	
Remove Cap	2020	Land Value	933	933	11%	103	Assessed	42,273	4,401.96
Year Frozen		Improvements	383,367	383,367		42,170	Penalty	0	
Uncapped Value	0	Mobile Home	0	0		0	Exemption	1,000	-87.00
TIF Project ID	0	Total Value	384,300	384,300		42,273	Total Taxable	41,273	4,315.00
Assessment History									
Tax Year	Statement Number	Billed Owner			Tax Area	Total Value	Exemptions	Taxable Value	Billed Tax
2025	2025-660103495	JONES, ERIN & JAY			4	391,817	1000	42,100	4,401.00
2024	2024-660103495	JONES, ERIN & JAY			4	415,956	1000	42,905	4,123.00
2023	2023-660103495	JONES, ERIN & JAY			4	387,504	1000	41,626	3,940.00
2022	2022-660103495	JONES, ERIN & JAY			4	933	0	103	10.00
2021	2021-660103495	JONES, ERIN & JAY			4	933	0	103	10.00
2020	2020-660103495	JONES, ERIN & JAY			4	933	0	103	10.00



Rogers

Assessment Property Record Card for Tax Year 2026

Data provided by LISA DELOZIER County Assessor

Date 04/18/2026
Time 10:04:47
Page 2

Lot Data	Units-Buildable - UNPLATTED (UNITS BUILDABLE)	Primary Image
Lot Size Lot Count Units Buildable Non-Ag Acres Topography Street Access Utilities Amenities LAND QUALITY Method Units-Buildable Base Lot Value Factor Value Adjustments Lot Value		<p>\\tsclient\X\Rob Stuff\ROBS NEW CONST\2022-9-1\IMG_0001.JPG 9/1/2022</p>

Residential Data	
Type	1 Single Family Residence
Condition	3 - Average
Quality	3.5 - Average
Architecture	
Style	100% One Story
Exterior Wall	100% Veneer, Masonry
Base/Total Area	2,486 / 2,486
Style	100% One Story
HVAC	100% Warmed & Cooled Air
Roof Cover	1 Composition Shingle
Area on Slab	2,486
Fixture/RghIn	/
Bed/F/H Bath	4 / 3.0 /
Basement Area	
Garage Type	970 Attached Garage - Finished
Remodel	
Year/Eff Age	2022 / 3

Cost Approach		Manual : 01/2025	
Base Cost	108.79	Total Misc Impr	+ 21,384
Roofing Adj	+ 5.16	Garage Cost	+ 45,241
Subfloor Adj	+ -3.38	Total RCN	= 395,224
Heat/Cool Adj	+ 14.47	Depreciation (3%)	- 11,857
Plumbing Adj	+ 7.14	Lump Sums	+ 0
Basement Adj	+ 0.00	RCNLD	= 383,367
Adj Base Cost	= 132.18	Lot Value	+ 383,367
Total Area	x 2,486	Indicated Value	= 383,367
Adjusted Cost	= 328,599	Value Per SqFt	154.21

GRM Approach	
GRM Code	
Gross Rent	0.00
Indicated Value	

Multiple Regression
MRA Code
Adusted R
Indicated Value

Direct Comparables	
Selection Model	1 Res
Adjustment Model	A2 AO Test
Comparables	
Indicated Value	

Value Reconciliation	
Selected Approach	Cost Approach
Improvements	383,367
Lot Value	
Indicated Value	383,367 154.21 Per SqFt
Agland Value	933
Site Improvements	
Total Value	384,300 154.59 Total Value Per SqFt

Miscellaneous Improvements								
Code	Description	Sketch ID	Size	Year	Units	Unit Cost	Depr	Value
PRCH	Slab Porch - Covered	154977	214		214	28.75		6,153
PRCH	Slab Porch - Covered	154978	20x14		280	28.54		7,991
PATO	Slab Porch - Open	154979	20x5		100	12.93		1,293
FPPF	Fireplace - Prefabricated			1 2023	1	5,947.13		5,947
SHLT	STORM SHELTER			1 2023	1	0.00		



Rogers

Assessment Property Record Card for Tax Year 2026

Data provided by LISA DELOZIER County Assessor

Date 04/18/2026
 Time 10:04:47
 Page 3

Sketch Image

660103495

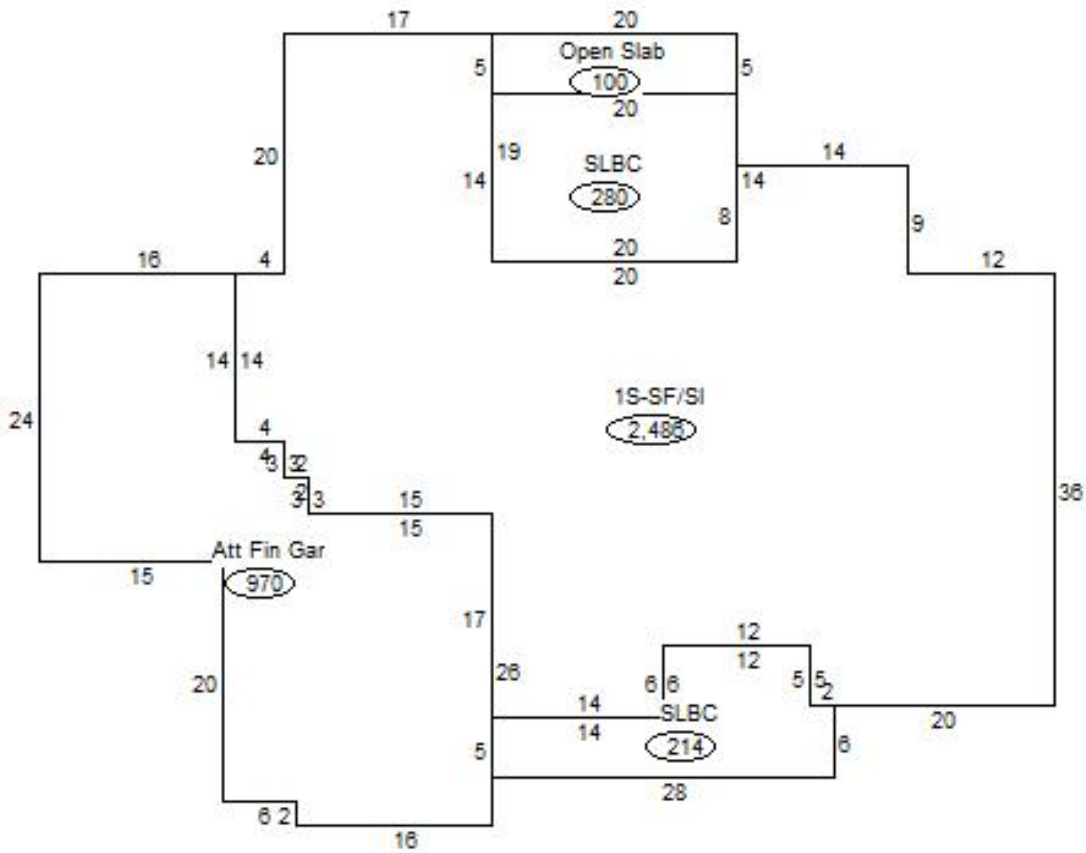

Sketch Vector Information

Sequence	Code	Type	Built Over	Scale	Section Label	Base Area	Multiplier	Total Area
1	R	1	Slab	20	1S-SF/SI	2,486	1.000	2,486
2	G	5		20	Att Fin Gar	970	1.000	970
3	M	PRCH		20	SLBC	214	1.000	214
4	M	PRCH		20	SLBC	280	1.000	280
5	M	PATO		20	Open Slab	100	1.000	100
Total Building Area						2,486		2,486



Rogers

Assessment Property Record Card for Tax Year 2026

Data provided by LISA DELOZIER County Assessor

Date 04/18/2026
Time 10:04:48
Page 4

Agland Inventory

660103495

Soi	Description	Land Use	LPI	Adj Type	Adj Code	Acres	Use/Acre	Mkt/Acre	Use Value	Market Value
SUB	SUMMIT SILTY CLAY LOAM 1-	TMBR	78			1.900	140	140	267	267
TMBR Totals						1.900			267	267
SUB	SUMMIT SILTY CLAY LOAM 1-	IMP PST	78			3.050	218	218	666	666
IMP PST Totals						3.050			666	666
Total Agland						4.950			933	933