



# Rogers

## Assessment Property Record Card for Tax Year 2026

Data provided by LISA DELOZIER County Assessor

Date 04/18/2026  
Time 10:06:13  
Page 1

Assessment Data					Primary Image				
Account	660103644				<p>01/11/2023</p> <p>\\tsclient\T\ROB STUFF\2023-1-11\IMG_0009.JPG 1/12/2023</p>				
Parcel ID	21N15E-32-4-00000-001-0099								
Cadastral ID	32-21-15-00722								
Property Type	REAL - Real Property								
Property Class	RA	VI Area	4						
Tax Area	4 - VERDIGRIS/VERD FIRE								
Name ID	330054								
KING, KELLY JOHN & ERICA SHAYE									
24452 S 4090 RD CLAREMORE OK 74019-0000									
Parcel Location									
Situs	24452 S 4090 RD								
Subdivision									
Lot/Block	/	Parcel Size	20 - Acres						
Sec/Twn/Rng	32 / 21 / 15 / 4								
Neighborhood	6090 - UNPLATTED								
School District	S008 - VERDIGRIS SCHOOLS								
Legal Description Lat/Long: 36.25399621 -95.72707269									
SE NW SE & SW NE SE									
Building Permits									
Number		Description		Opened	Closed	Amount			
R20		R23-SPLIT		05/2020	01/2023				
Exemptions									
Sale History									
Code	Type	Active	Maximum	Exemption	Bk/Pg	Grantor	Date	Price	Code
					/	RISENHOOVER, RANDAL R &	02/07/2020	210,000	YES
Parcel Valuation									
Source	REAL		Fair Cash	Capped	Asmnt Level	Assessed	Levy Rate	104.132	Current Tax
Remove Cap	2020	Land Value	2,724	2,724	11%	300	Assessed	67,813	7,061.49
Year Frozen		Improvements	671,520	613,749		67,513	Penalty	0	
Uncapped Value	0	Mobile Home	0	0		0	Exemption	0	0.00
TIF Project ID	0	Total Value	674,244	616,473		67,813	Total Taxable	67,813	7,061.00
Assessment History									
Tax Year	Statement Number	Billed Owner			Tax Area	Total Value	Exemptions	Taxable Value	Billed Tax
2025	2025-660103644	KING, KELLY JOHN & ERICA SHAYE			4	598,518	0	65,838	6,856.00
2024	2024-660103644	KING, KELLY JOHN & ERICA SHAYE			4	622,840	0	67,797	6,498.00
2023	2023-660103644	KING, KELLY JOHN & ERICA SHAYE			4	48,935	0	5,383	508.00
2022	2022-660103644	KING, KELLY JOHN & ERICA SHAYE			4	48,935	0	5,383	517.00
2021	2021-660103644	KING, KELLY JOHN & ERICA SHAYE			4	2,724	0	300	28.00
2020	2020-660103644	KING, KELLY JOHN & ERICA SHAYE			4	2,724	0	300	28.00



# Rogers

## Assessment Property Record Card for Tax Year 2026

Data provided by LISA DELOZIER County Assessor

Date 04/18/2026  
 Time 10:06:13  
 Page 2

Lot Data	Units-Buildable - UNPLATTED (UNITS BUILDABLE)	Primary Image
Lot Size Lot Count Units Buildable Non-Ag Acres Topography Street Access Utilities Amenities LAND QUALITY  Method Units-Buildable Base Lot Value Factor Value Adjustments Lot Value		 <p>\\tsclient\T\ROB STUFF\2023-1-11\IMG_0009.JPG 1/12/2023</p>

Residential Data	
Type	1 Single Family Residence
Condition	3 - Average
Quality	4.5 - Good
Architecture	
Style	100% 1 1/2 Story Finished
Exterior Wall	90% Veneer, Masonry 10% Veneer, Stone
Base/Total Area	2,880 / 3,807
Style	100% 1 1/2 Story Finished
HVAC	100% Warmed & Cooled Air
Roof Cover	1 Composition Shingle
Area on Slab	2,880
Fixture/RghIn	/
Bed/F/H Bath	4 / 4.0 / 1.0
Basement Area	
Garage Type	948 Attached Garage - Finished
Remodel	
Year/Eff Age	2023 / 2

GRM Approach	
GRM Code	
Gross Rent	0.00
Indicated Value	

Multiple Regression
MRA Code
Adusted R
Indicated Value

Direct Comparables	
Selection Model	1 Res
Adjustment Model	A2 AO Test
Comparables	
Indicated Value	

Cost Approach				Manual : 01/2025			
Base Cost	105.42	Total Misc Impr	+ 45,765	Roofing Adj	+ 4.58	Garage Cost	+ 57,515
Subfloor Adj	+ -3.31	Total RCN	= 606,147	Heat/Cool Adj	+ 17.38	Depreciation ( 2%)	- 12,123
Plumbing Adj	+ 8.02	Lump Sums	+ 0	Basement Adj	+ 0.00	RCNLD	= 594,024
Adj Base Cost	= 132.09	Lot Value	+ 594,024	Total Area	x 3,807	Indicated Value	= 594,024
Adjusted Cost	= 502,867	Value Per SqFt	156.03	Adjusted Cost	= 502,867	Value Per SqFt	156.03

Value Reconciliation		
Selected Approach	Cost Approach	
Improvements	594,024	
Lot Value		
Indicated Value	594,024	156.03 Per SqFt
Agland Value	2,724	
Site Improvements	77,496	
Total Value	674,244	177.11 Total Value Per SqFt

Miscellaneous Improvements								
Code	Description	Sketch ID	Size	Year	Units	Unit Cost	Depr	Value
PRCH	Slab Porch - Covered	156204	341		341	35.06		11,955
PATO	Slab Porch - Open	156205	424		424	11.40		4,834
PRCH	Slab Porch - Covered	156206	567		567	34.32		19,459
PATO	Slab Porch - Open	156207	15x8		120	14.97		1,796
FPR1	Fireplace - Residential 1 Story		1		1	7,721.18		7,721
SHLT	STORM SHELTER (AG)		1		1	0.00		



# Rogers

## Assessment Property Record Card for Tax Year 2026

Data provided by LISA DELOZIER County Assessor

Date 04/18/2026

Time 10:06:13

Page 3

Sketch Image

660103644

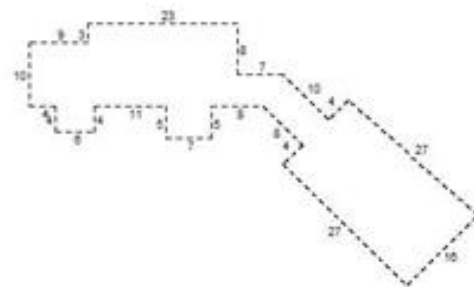
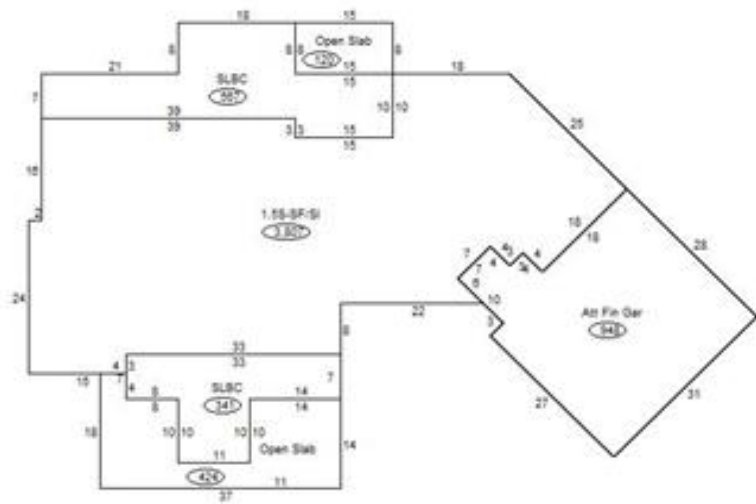

### Sketch Vector Information

Sequence	Code	Type	Built Over	Scale	Section Label	Base Area	Multiplier	Total Area
1	R	5	Slab	20	1.5S-SF/SI	2,880	1.322	3,807
2	G	5		20	Att Fin Gar	948	1.000	948
3	M	PRCH		20	SLBC	341	1.000	341
4	M	PATO		20	Open Slab	424	1.000	424
5	M	PRCH		20	SLBC	567	1.000	567
6	M	PATO		20	Open Slab	120	1.000	120
7	U	^UL		20	Upper Level (1)	927	1.000	927
<b>Total Building Area</b>						<b>2,880</b>		<b>3,807</b>



# Rogers



## Assessment Property Record Card for Tax Year 2026

Data provided by LISA DELOZIER County Assessor

Date 04/18/2026  
 Time 10:06:13  
 Page 4

660103644

### Outbuildings/Site Improvements

Building Image	Code	Description	Dimensions	Floor	Roofing	Total Units
	UTIL	Shop Building	60x50x0			3,000
	Qual	3	Cond 3	Year 2021	Eff Age 4	
	<b>Valuation Summary</b> Base Cost (26.91 x 3,000) 80,730		<b>Modifier Total</b>	<b>RCN</b> 80,730	<b>Depr (7% Phys/ % Func)</b> 5,651	<b>RCNLD</b> 75,079
	PATO	Slab Porch - BACK OF SHOP	35x10x0			350
	Qual	3	Cond 3	Year 2021	Eff Age 4	
	<b>Valuation Summary</b> Base Cost (8.74 x 350) 3,059		<b>Modifier Total</b>	<b>RCN</b> 3,059	<b>Depr (21% Phys/ % Func)</b> 642	<b>RCNLD</b> 2,417



# Rogers

## Assessment Property Record Card for Tax Year 2026

Data provided by LISA DELOZIER County Assessor

Date 04/18/2026  
Time 10:06:13  
Page 5

### Agland Inventory

660103644

Soi	Description	Land Use	LPI	Adj Type	Adj Code	Acres	Use/Acre	Mkt/Acre	Use Value	Market Value
VE	VERDIGRIS CLAY LOAM	TMBR	90			4.000	162	162	648	648
<b>TMBR Totals</b>						4.000			648	648
BR	BREAKS-ALLUVIAL LAND COMP	NTV PST	30			2.000	72	72	144	144
RVC	RIVERTON GRAVELLY LOAM 3-	NTV PST	61			3.000	146	146	439	439
RVC	RIVERTON GRAVELLY LOAM 3-	NTV PST	61			4.000	146	146	586	586
RVC2	RIVERTON GRAVELLY LOAM 3-	NTV PST	54			7.000	130	130	907	907
<b>NTV PST Totals</b>						16.000			2,076	2,076
<b>Total Agland</b>						20.000			2,724	2,724