



# Rogers

## Assessment Property Record Card for Tax Year 2026

Data provided by LISA DELOZIER County Assessor

Date 04/18/2026  
Time 10:10:45  
Page 1

Assessment Data				Primary Image						
Account	660104269			<p>660104269_001.JPG 10/7/2025</p>						
Parcel ID	000000-0-0-000249-002-0001									
Cadastral ID	06-20-15-02530									
Property Type	REAL - Real Property									
Property Class	RRP	VI Area	3							
Tax Area	20 - CATOOSA RURAL									
Name ID	333596									
WOOTEN, BRIAN D										
6110 N CREEKWOOD DR OWASSO OK 74055-0000										
Parcel Location										
Situs	06110 N CREEKWOOD DR									
Subdivision	DEER RUN AT STONE CANYON PHASE III									
Lot/Block	0001 / 0002	Parcel Size	1 - Lots							
Sec/Twn/Rng	6 / 20 / 15 / 5									
Neighborhood	1039 - R-V04, SW OWASSO									
School District	S002 - CATOOSA SCHOOLS									
Legal Description Lat/Long: 36.24242860 -95.76041511				Building Permits						
LOT 1 BLOCK 2 DEER RUN AT STONE CANYON PHASE III				Number	Description	Opened	Closed	Amount		
				R20 284	R22- NEW 3458 SQ FT SFR	10/2020	03/2021	225,000		
Exemptions				Sale History						
Code	Type	Active	Maximum	Exemption	Bk/Pg	Grantor	Date	Price	Code	
					/	EXECUTIVE HOMES LLC	02/16/2021	517,500	YES	
					/	C.A.B.O DEVELOPMENT COMPANY LL	06/03/2020	572,500	WB	
Parcel Valuation										
Source	REAL		Fair Cash	Capped	Asmnt Level	Assessed	Levy Rate	92.860	Current Tax	
Remove Cap	2022		Land Value	121,567	121,567	11%	13,372	Assessed	65,897	6,119.20
Year Frozen			Improvements	483,985	477,503		52,525	Penalty	0	
Uncapped Value	0		Mobile Home	0	0		0	Exemption	0	0.00
TIF Project ID	0		Total Value	605,552	599,070		65,897	Total Taxable	65,897	6,119.00
Assessment History										
Tax Year	Statement Number	Billed Owner		Tax Area	Total Value	Exemptions	Taxable Value	Billed Tax		
2025	2025-660104269	WOOTEN, BRIAN D		20	585,200	0	62,760	5,828.00		
2024	2024-660104269	WOOTEN, BRIAN D		20	605,801	0	59,771	5,407.00		
2023	2023-660104269	WOOTEN, BRIAN D		20	517,500	0	56,925	4,942.00		
2022	2022-660104269	WOOTEN, BRIAN D		20	517,500	0	56,925	4,955.00		
2021	2021-660104269	WOOTEN, BRIAN D		20	81,000	0	8,910	784.00		



# Rogers

## Assessment Property Record Card for Tax Year 2026

Data provided by LISA DELOZIER County Assessor

Date 04/18/2026  
Time 10:10:45  
Page 2

Lot Data	Square-Foot - NBHD 1039 #1	Primary Image
Lot Size	0 0	
Lot Count	1	
Units Buildable		
Non-Ag Acres	0.5347	
Topography		
Street Access		
Utilities		
Amenities	0	
	0	
Method	Square-Foot	
Base Lot Value	23,290.00 x 5.22 = 121,567	
Factor Value		
Adjustments	1.0000	
Lot Value	121,567	

Residential Data	
Type	1 Single Family Residence
Condition	3 - Average
Quality	4 - Good
Architecture	TRAD TRADITIONAL
Style	100% 1 1/2 Story Finished
Exterior Wall	90% Veneer, Masonry 10% Frame, Siding, Wood
Base/Total Area	2,809 / 3,499
Style	100% 1 1/2 Story Finished
HVAC	100% Warmed & Cooled Air
Roof Cover	1 Composition Shingle
Area on Slab	2,809
Fixture/RghIn	16 /
Bed/F/H Bath	5 / 3.0 / 1.0
Basement Area	
Garage Type	772 Attached Garage - Finished 3 Stalls
Remodel	
Year/Eff Age	2021 / 4

Cost Approach		Manual : 01/2025	
Base Cost	99.71	Total Misc Impr	+ 21,861
Roofing Adj	+ 4.58	Garage Cost	+ 43,935
Subfloor Adj	+ -3.51	Total RCN	= 504,151
Heat/Cool Adj	+ 16.31	Depreciation ( 4%)	- 20,166
Plumbing Adj	+ 8.19	Lump Sums	+ 0
Basement Adj	+ 0.00	RCNLD	= 483,985
Adj Base Cost	= 125.28	Lot Value	+ 121,567
Total Area	x 3,499	Indicated Value	= 605,552
Adjusted Cost	= 438,355	Value Per SqFt	173.06



660104269\_001.JPG 10/7/2025

GRM Approach	
GRM Code	
Gross Rent	0.00
Indicated Value	

Multiple Regression			
MRA Code	1	Test	
Adusted R	0.8445		
Indicated Value	497,713	142.24	Per SqFt

Direct Comparables	
Selection Model	A Adam Test
Adjustment Model	1 2022 Residential
Comparables	6
Indicated Value	628,850 Per SqFt

Value Reconciliation			
Selected Approach	Cost Approach		
Improvements	483,985		
Lot Value	121,567		
Indicated Value	605,552	173.06	Per SqFt
Agland Value			
Site Improvements			
Total Value	605,552	173.06	Total Value Per SqFt

Miscellaneous Improvements								
Code	Description	Sketch ID	Size	Year	Units	Unit Cost	Depr	Value
FPR1	Fireplace - Residential 1 Story	0		1	1	7,243.87		7,244
PRCH	SLAB PORCH - COVERED	149658	21x14		294	31.96		9,396
PRCH	SLAB PORCH - COVERED	149659	8x5		40	33.07		1,323
PRCH	Porch	149660	17x7		119	32.76		3,898



# Rogers

## Assessment Property Record Card for Tax Year 2026

Data provided by LISA DELOZIER County Assessor

Date 04/18/2026

Time 10:10:45

Page 3

Sketch Image

660104269

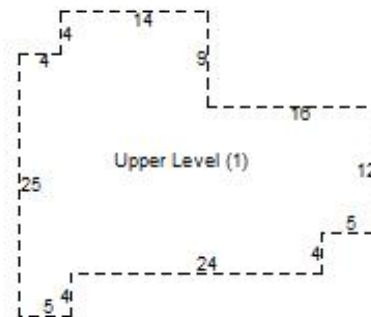
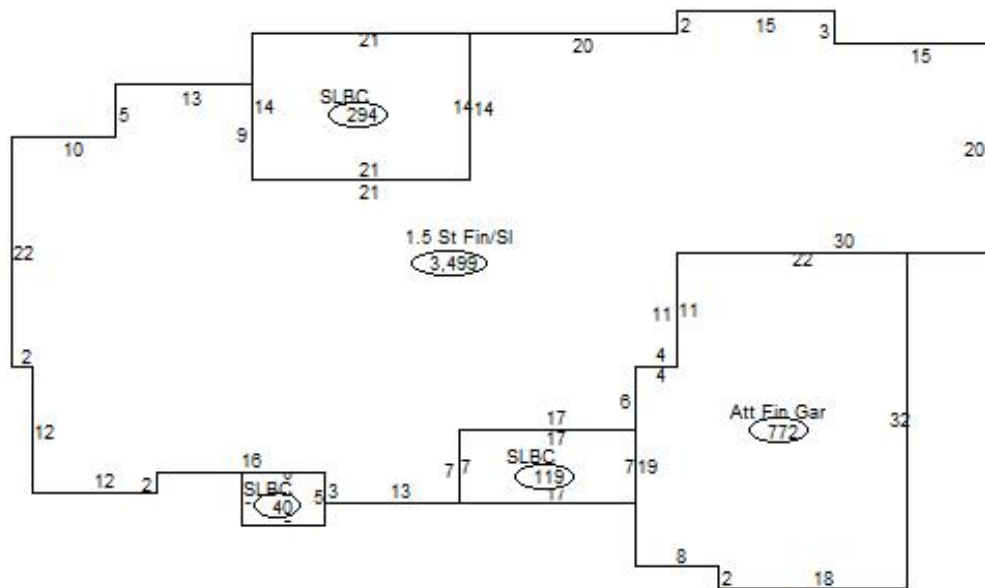

### Sketch Vector Information

Sequence	Code	Type	Built Over	Scale	Section Label	Base Area	Multiplier	Total Area
1	R	5	Slab	20	1.5 St Fin/SI	2,809	1.246	3,499
2	G	5		20	Att Fin Gar	772	1.000	772
3	M	PRCH		20	SLBC	294	1.000	294
4	M	PRCH		20	SLBC	40	1.000	40
5	M	PRCH		20	SLBC	119	1.000	119
6	U	^UL		20	Upper Level (1)	690	1.000	690
<b>Total Building Area</b>						<b>2,809</b>		<b>3,499</b>