



Rogers

Assessment Property Record Card for Tax Year 2026

Data provided by LISA DELOZIER County Assessor

Date 04/18/2026
Time 10:11:59
Page 1

Assessment Data				Primary Image															
Account 660104313 Parcel ID 000000-0-0-000637-001-0010 Cadastral ID 10-21-14-08700 Property Type REAL - Real Property Property Class RRP VI Area 4 Tax Area 3 - OWASSO RURAL/NO FIRE Name ID 338314 POTTER, MISTY DAWN 10826 N 158TH E AVE OWASSO OK 74055-0000 Parcel Location Situs 10826 N 158TH E AVE Subdivision PRESTIGE POND Lot/Block 0010 / 0001 Parcel Size 1 - Lots Sec/Twn/Rng 10 / 21 / 14 / 5 Neighborhood 1042 - R-V03-SW OWASSO School District S021 - OWASSO SCHOOLS																			
Legal Description Lat/Long: 36.31088940 -95.79860014				Building Permits															
LOT 10 BLOCK 1 PRESTIGE POND				<table border="1"> <thead> <tr> <th>Number</th> <th>Description</th> <th>Opened</th> <th>Closed</th> <th>Amount</th> </tr> </thead> <tbody> <tr> <td>R21 000261</td> <td>R23- NEW 2867 SQ FT SFR</td> <td>07/2021</td> <td>08/2022</td> <td>230,000</td> </tr> </tbody> </table>						Number	Description	Opened	Closed	Amount	R21 000261	R23- NEW 2867 SQ FT SFR	07/2021	08/2022	230,000
Number	Description	Opened	Closed	Amount															
R21 000261	R23- NEW 2867 SQ FT SFR	07/2021	08/2022	230,000															
Exemptions				Sale History															
Code	Type	Active	Maximum	Exemption	Bk/Pg	Grantor	Date	Price	Code										
					/	EXECUTIVE HOMES LLC	05/06/2022	524,000	YES										
					/	PRESTIGE POND LLC	04/30/2021	1,425,000	WB										
Parcel Valuation																			
Source	REAL		Fair Cash	Capped	Asmnt Level	Assessed	Levy Rate	97.960	Current Tax										
Remove Cap	2023		Land Value	119,297	119,297	11%	Assessed	59,063	5,785.81										
Year Frozen			Improvements	417,633	417,633		Penalty	0											
Uncapped Value	0		Mobile Home	0	0		Exemption	0	0.00										
TIF Project ID	0		Total Value	536,930	536,930		Total Taxable	59,063	5,786.00										
Assessment History																			
Tax Year	Statement Number	Billed Owner			Tax Area	Total Value	Exemptions	Taxable Value	Billed Tax										
2025	2025-660104313	POTTER, MISTY DAWN			3	519,756	0	57,173	5,601.00										
2024	2024-660104313	POTTER, MISTY DAWN			3	524,000	0	57,640	5,537.00										
2023	2023-660104313	POTTER, MISTY DAWN			3	524,000	0	57,640	5,401.00										
2022	2022-660104313	POTTER, MISTY DAWN			3	10,000	0	1,100	108.00										
2021	2021-660104313	EXECUTIVE HOMES LLC			3	10,000	0	1,100	106.00										



Rogers

Assessment Property Record Card for Tax Year 2026

Data provided by LISA DELOZIER County Assessor

Date 04/18/2026
Time 10:11:59
Page 2

Lot Data		Square-Foot - NBHD 1042 #1	
Lot Size	0	0	
Lot Count	1		
Units Buildable			
Non-Ag Acres	0.5173		
Topography			
Street Access			
Utilities			
Amenities			0
			0
Method	Square-Foot		
Base Lot Value	22,534.00 x 4.21 = 94,893		
Factor Value			
Adjustments	1.2572		
Lot Value	119,297		



\\tsclient\X\Rob Stuff\ROBS NEW CONST\2022-8-9\IMG_0013.JPG 8/9/2022

Residential Data	
Type	1 Single Family Residence
Condition	3 - Average
Quality	4.5 - Good
Architecture	
Style	100% One Story
Exterior Wall	95% Veneer, Masonry 5% Veneer, Stone
Base/Total Area	2,593 / 2,593
Style	100% One Story
HVAC	100% Warmed & Cooled Air
Roof Cover	1 Composition Shingle
Area on Slab	2,593
Fixture/RghIn	/
Bed/F/H Bath	3 / 2.0 / 1.0
Basement Area	
Garage Type	743 Attached Garage - Finished
Remodel	
Year/Eff Age	2022 / 3

GRM Approach	
GRM Code	
Gross Rent	0.00
Indicated Value	

Multiple Regression			
MRA Code	1	Test	
Adusted R	0.8445		
Indicated Value	441,048	170.09	Per SqFt

Direct Comparables			
Selection Model	A	Adam Test	
Adjustment Model	1	2022 Residential	
Comparables	2		
Indicated Value	537,450		Per SqFt

Cost Approach		Manual : 01/2025	
Base Cost	118.51	Total Misc Impr	+ 9,486
Roofing Adj	+ 6.16	Garage Cost	+ 45,078
Subfloor Adj	+ -4.57	Total RCN	= 430,549
Heat/Cool Adj	+ 17.38	Depreciation (3%)	- 12,916
Plumbing Adj	+ 7.52	Lump Sums	+ 0
Basement Adj	+ 0.00	RCNLD	= 417,633
Adj Base Cost	= 145.00	Lot Value	+ 119,297
Total Area	x 2,593	Indicated Value	= 536,930
Adjusted Cost	= 375,985	Value Per SqFt	207.07

Value Reconciliation			
Selected Approach	Cost Approach		
Improvements	417,633		
Lot Value	119,297		
Indicated Value	536,930	207.07	Per SqFt
Agland Value			
Site Improvements			
Total Value	536,930	207.07	Total Value Per SqFt

Miscellaneous Improvements								
Code	Description	Sketch ID	Size	Year	Units	Unit Cost	Depr	Value
PRCH	Slab Porch - Covered	154493	5x4		20	36.62		732
PRCH	Slab Porch - Covered	154494	19x13		247	35.44		8,754



Rogers

Assessment Property Record Card for Tax Year 2026

Data provided by LISA DELOZIER County Assessor

Date 04/18/2026
 Time 10:11:59
 Page 3

Sketch Image

660104313

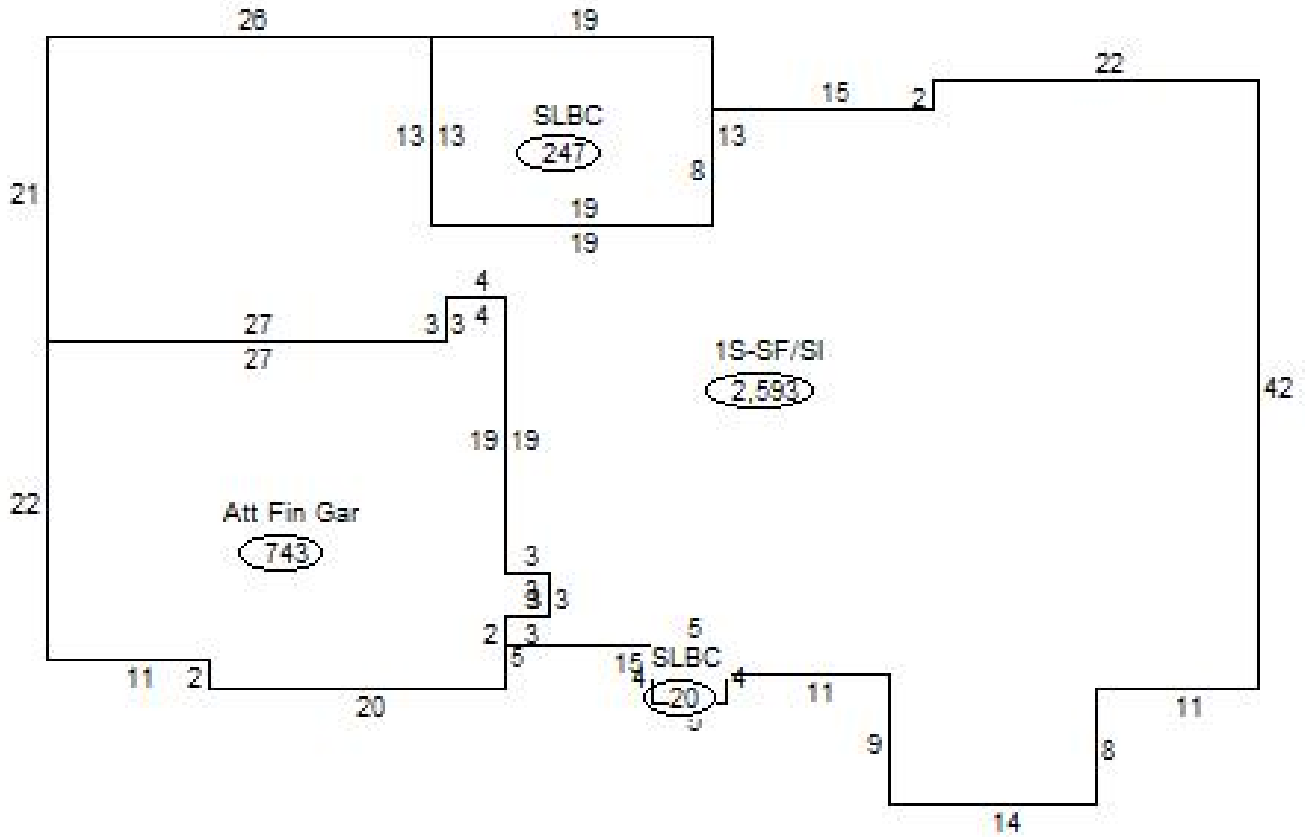

Sketch Vector Information

Sequence	Code	Type	Built Over	Scale	Section Label	Base Area	Multiplier	Total Area
1	R	1	Slab	20	1S-SF/SI	2,593	1.000	2,593
2	G	5		20	Att Fin Gar	743	1.000	743
3	M	PRCH		20	SLBC	20	1.000	20
4	M	PRCH		20	SLBC	247	1.000	247
Total Building Area						2,593		2,593