



Rogers

Assessment Property Record Card for Tax Year 2026

Data provided by LISA DELOZIER County Assessor

Date 04/18/2026
Time 10:12:23
Page 1

Assessment Data					Primary Image																																																																
Account 660104326 Parcel ID 000000-0-0-000637-004-0005 Cadastral ID 10-21-14-08830 Property Type REAL - Real Property Property Class RRP VI Area 4 Tax Area 3 - OWASSO RURAL/NO FIRE Name ID 337912 BIVINS, GRADY WAYNE 10731 N 159TH E AVE OWASSO OK 74055-0000 Parcel Location Situs 10731 N 159TH E AVE Subdivision PRESTIGE POND Lot/Block 0005 / 0004 Parcel Size 1 - Lots Sec/Twn/Rng 10 / 21 / 14 / 5 Neighborhood 1042 - R-V03-SW OWASSO School District S021 - OWASSO SCHOOLS					<p>\\tsclient\X\Rob Stuff\ROBS NEW CONST\2022-8-10\IMG_0010.JF 8/10/2022</p>																																																																
Legal Description Lot/Long: 36.31049536 -95.79694536 LOT 5 BLOCK 4 PRESTIGE POND																																																																					
Exemptions <table border="1"> <thead> <tr> <th>Code</th> <th>Type</th> <th>Active</th> <th>Maximum</th> <th>Exemption</th> </tr> </thead> <tbody> <tr> <td>H</td> <td>Homestead</td> <td>Yes</td> <td>1,000</td> <td>1,000</td> </tr> </tbody> </table>					Code	Type	Active	Maximum	Exemption	H	Homestead	Yes	1,000	1,000	Building Permits <table border="1"> <thead> <tr> <th>Number</th> <th>Description</th> <th>Opened</th> <th>Closed</th> <th>Amount</th> </tr> </thead> <tbody> <tr> <td>R21 000315</td> <td>R23- NEW 3355 SQ FT SFR</td> <td>08/2021</td> <td>08/2022</td> <td>235,000</td> </tr> </tbody> </table>					Number	Description	Opened	Closed	Amount	R21 000315	R23- NEW 3355 SQ FT SFR	08/2021	08/2022	235,000																																								
Code	Type	Active	Maximum	Exemption																																																																	
H	Homestead	Yes	1,000	1,000																																																																	
Number	Description	Opened	Closed	Amount																																																																	
R21 000315	R23- NEW 3355 SQ FT SFR	08/2021	08/2022	235,000																																																																	
Parcel Valuation <table border="1"> <thead> <tr> <th>Source</th> <th>REAL</th> <th>Fair Cash</th> <th>Capped</th> <th>Asmnt Level</th> <th>Assessed</th> <th>Levy Rate</th> <th>97.960</th> <th>Current Tax</th> </tr> </thead> <tbody> <tr> <td>Remove Cap</td> <td>2023</td> <td>Land Value</td> <td>95,163</td> <td>95,163</td> <td>11%</td> <td>10,468</td> <td>Assessed</td> <td>66,769 6,540.69</td> </tr> <tr> <td>Year Frozen</td> <td></td> <td>Improvements</td> <td>514,981</td> <td>511,831</td> <td></td> <td>56,301</td> <td>Penalty</td> <td>0</td> </tr> <tr> <td>Uncapped Value</td> <td>0</td> <td>Mobile Home</td> <td>0</td> <td>0</td> <td></td> <td>0</td> <td>Exemption</td> <td>1,000 -98.00</td> </tr> <tr> <td>TIF Project ID</td> <td>0</td> <td>Total Value</td> <td>610,144</td> <td>606,994</td> <td></td> <td>66,769</td> <td>Total Taxable</td> <td>65,769 6,443.00</td> </tr> </tbody> </table>					Source	REAL	Fair Cash	Capped	Asmnt Level	Assessed	Levy Rate	97.960	Current Tax	Remove Cap	2023	Land Value	95,163	95,163	11%	10,468	Assessed	66,769 6,540.69	Year Frozen		Improvements	514,981	511,831		56,301	Penalty	0	Uncapped Value	0	Mobile Home	0	0		0	Exemption	1,000 -98.00	TIF Project ID	0	Total Value	610,144	606,994		66,769	Total Taxable	65,769 6,443.00	Sale History <table border="1"> <thead> <tr> <th>Bk/Pg</th> <th>Grantor</th> <th>Date</th> <th>Price</th> <th>Code</th> </tr> </thead> <tbody> <tr> <td>/</td> <td>EXECUTIVE HOMES LLC</td> <td>04/06/2022</td> <td>581,000</td> <td>YES</td> </tr> <tr> <td>/</td> <td>PRESTIGE POND LLC</td> <td>04/30/2021</td> <td>1,425,000</td> <td>WB</td> </tr> </tbody> </table>					Bk/Pg	Grantor	Date	Price	Code	/	EXECUTIVE HOMES LLC	04/06/2022	581,000	YES	/	PRESTIGE POND LLC	04/30/2021	1,425,000	WB
Source	REAL	Fair Cash	Capped	Asmnt Level	Assessed	Levy Rate	97.960	Current Tax																																																													
Remove Cap	2023	Land Value	95,163	95,163	11%	10,468	Assessed	66,769 6,540.69																																																													
Year Frozen		Improvements	514,981	511,831		56,301	Penalty	0																																																													
Uncapped Value	0	Mobile Home	0	0		0	Exemption	1,000 -98.00																																																													
TIF Project ID	0	Total Value	610,144	606,994		66,769	Total Taxable	65,769 6,443.00																																																													
Bk/Pg	Grantor	Date	Price	Code																																																																	
/	EXECUTIVE HOMES LLC	04/06/2022	581,000	YES																																																																	
/	PRESTIGE POND LLC	04/30/2021	1,425,000	WB																																																																	
Assessment History <table border="1"> <thead> <tr> <th>Tax Year</th> <th>Statement Number</th> <th>Billed Owner</th> <th>Tax Area</th> <th>Total Value</th> <th>Exemptions</th> <th>Taxable Value</th> <th>Billed Tax</th> </tr> </thead> <tbody> <tr> <td>2025</td> <td>2025-660104326</td> <td>BIVINS, GRADY WAYNE</td> <td>3</td> <td>589,315</td> <td>1000</td> <td>63,825</td> <td>6,252.00</td> </tr> <tr> <td>2024</td> <td>2024-660104326</td> <td>BIVINS, GRADY WAYNE</td> <td>3</td> <td>593,202</td> <td>1000</td> <td>64,252</td> <td>6,173.00</td> </tr> <tr> <td>2023</td> <td>2023-660104326</td> <td>BIVINS, GRADY WAYNE</td> <td>3</td> <td>581,000</td> <td>1000</td> <td>62,910</td> <td>5,895.00</td> </tr> <tr> <td>2022</td> <td>2022-660104326</td> <td>BIVINS, GRADY WAYNE</td> <td>3</td> <td>10,000</td> <td>0</td> <td>1,100</td> <td>108.00</td> </tr> <tr> <td>2021</td> <td>2021-660104326</td> <td>EXECUTIVE HOMES LLC</td> <td>3</td> <td>10,000</td> <td>0</td> <td>1,100</td> <td>106.00</td> </tr> </tbody> </table>										Tax Year	Statement Number	Billed Owner	Tax Area	Total Value	Exemptions	Taxable Value	Billed Tax	2025	2025-660104326	BIVINS, GRADY WAYNE	3	589,315	1000	63,825	6,252.00	2024	2024-660104326	BIVINS, GRADY WAYNE	3	593,202	1000	64,252	6,173.00	2023	2023-660104326	BIVINS, GRADY WAYNE	3	581,000	1000	62,910	5,895.00	2022	2022-660104326	BIVINS, GRADY WAYNE	3	10,000	0	1,100	108.00	2021	2021-660104326	EXECUTIVE HOMES LLC	3	10,000	0	1,100	106.00												
Tax Year	Statement Number	Billed Owner	Tax Area	Total Value	Exemptions	Taxable Value	Billed Tax																																																														
2025	2025-660104326	BIVINS, GRADY WAYNE	3	589,315	1000	63,825	6,252.00																																																														
2024	2024-660104326	BIVINS, GRADY WAYNE	3	593,202	1000	64,252	6,173.00																																																														
2023	2023-660104326	BIVINS, GRADY WAYNE	3	581,000	1000	62,910	5,895.00																																																														
2022	2022-660104326	BIVINS, GRADY WAYNE	3	10,000	0	1,100	108.00																																																														
2021	2021-660104326	EXECUTIVE HOMES LLC	3	10,000	0	1,100	106.00																																																														



Rogers

Assessment Property Record Card for Tax Year 2026

Data provided by LISA DELOZIER County Assessor

Date 04/18/2026
Time 10:12:23
Page 2

Lot Data		Square-Foot - NBHD 1042 #1	
Lot Size	0	0	
Lot Count	1		
Units Buildable			
Non-Ag Acres	0.5188		
Topography			
Street Access			
Utilities			
Amenities		0	
		0	
Method	Square-Foot		
Base Lot Value	22,598.00 x 4.21 = 95,163		
Factor Value			
Adjustments	1.0000		
Lot Value	95,163		



\\tsclient\X\Rob Stuff\ROBS NEW CONST\2022-8-10\IMG_0010.JF 8/10/2022

Residential Data	
Type	1 Single Family Residence
Condition	3 - Average
Quality	4.5 - Good
Architecture	
Style	100% One Story
Exterior Wall	95% Veneer, Masonry 5% Veneer, Stone
Base/Total Area	3,377 / 3,377
Style	100% One Story
HVAC	100% Warmed & Cooled Air
Roof Cover	1 Composition Shingle
Area on Slab	3,377
Fixture/RghIn	/
Bed/F/H Bath	5 / 3.0 / 1.0
Basement Area	
Garage Type	717 Attached Garage - Finished
Remodel	
Year/Eff Age	2022 / 3

GRM Approach	
GRM Code	
Gross Rent	0.00
Indicated Value	

Multiple Regression			
MRA Code	1	Test	
Adusted R	0.8445		
Indicated Value	525,296	155.55	Per SqFt

Direct Comparables			
Selection Model	A	Adam Test	
Adjustment Model	1	2022 Residential	
Comparables	2		
Indicated Value	613,130		Per SqFt

Cost Approach		Manual : 01/2025	
Base Cost	112.95	Total Misc Impr	+ 16,591
Roofing Adj	+ 5.94	Garage Cost	+ 43,529
Subfloor Adj	+ -4.27	Total RCN	= 530,908
Heat/Cool Adj	+ 17.38	Depreciation (3%)	- 15,927
Plumbing Adj	+ 7.41	Lump Sums	+ 0
Basement Adj	+ 0.00	RCNLD	= 514,981
Adj Base Cost	= 139.41	Lot Value	+ 95,163
Total Area	x 3,377	Indicated Value	= 610,144
Adjusted Cost	= 470,788	Value Per SqFt	180.68

Value Reconciliation			
Selected Approach	Cost Approach		
Improvements	514,981		
Lot Value	95,163		
Indicated Value	610,144	180.68	Per SqFt
Agland Value			
Site Improvements			
Total Value	610,144	180.68	Total Value Per SqFt

Miscellaneous Improvements								
Code	Description	Sketch ID	Size	Year	Units	Unit Cost	Depr	Value
PRCH	Slab Porch - Covered	154545	7x5		35	36.56		1,280
PRCH	Slab Porch - Covered	154546	21x15		315	35.14		11,069
GENR	Generator - Residential Standby			1	2023	4,242.00		4,242



Rogers
Assessment Property Record Card for Tax Year 2026

Data provided by LISA DELOZIER County Assessor

Date 04/18/2026
 Time 10:12:23
 Page 3

Sketch Image

660104326

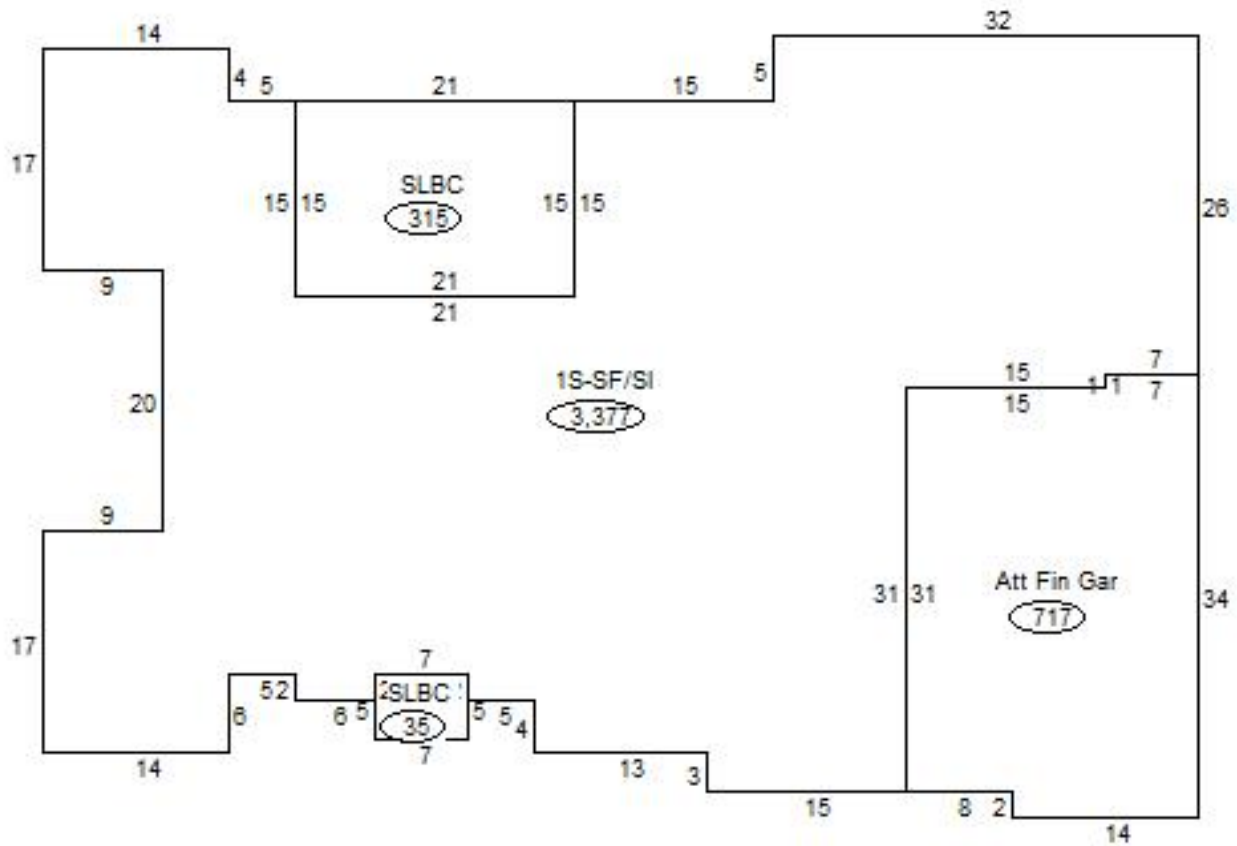

Sketch Vector Information

Sequence	Code	Type	Built Over	Scale	Section Label	Base Area	Multiplier	Total Area
1	R	1	Slab	20	1S-SF/SI	3,377	1.000	3,377
2	G	5		20	Att Fin Gar	717	1.000	717
3	M	PRCH		20	SLBC	35	1.000	35
4	M	PRCH		20	SLBC	315	1.000	315
Total Building Area						3,377		3,377