



Rogers

Assessment Property Record Card for Tax Year 2026

Data provided by LISA DELOZIER County Assessor

Date 04/18/2026
Time 10:15:20
Page 1

Assessment Data					Primary Image				
Account	660104497								
Parcel ID	00000-0-0-0000778-001-0012								
Cadastral ID	34-21-14-02220								
Property Type	REAL - Real Property								
Property Class	URP	VI Area	4						
Tax Area	40 - OWASSO CITY								
Name ID	341029								
SAMARANI, ELIE SALIM									
15702 E 75TH ST N OWASSO OK 74055-0000									
Parcel Location									
Situs	15702 E 75TH ST N								
Subdivision	STONE CREEK OF OWASSO								
Lot/Block	0012 / 0001	Parcel Size	1 - Lots						
Sec/Twn/Rng	34 / 21 / 14 / 5								
Neighborhood	1059 - R-V04-SW OWASSO								
School District	S021 - OWASSO SCHOOLS								
Legal Description Lat/Long: 36.26235309 -95.79836109									
Building Permits									
LOT 12 BLOCK 1 STONE CREEK OF OWASSO									
Number	Description	Opened	Closed	Amount					
R22 915	R23 NEW SFR 2046 SQ FT	10/2022	03/2023	112,530					
Exemptions									
Code	Type	Active	Maximum	Exemption					
H	Homestead	Yes	1,000	1,000					
Sale History									
Bk/Pg	Grantor	Date	Price	Code					
/	SHAW HOMES OKLAHOMA INC	03/15/2023	343,500	YES					
/	STONE CREEK PROPERTIES LLC	02/14/2022	2,842,000	WB					
Parcel Valuation									
Source	REAL	Fair Cash	Capped	Asmnt Level	Assessed	Levy Rate	97.960	Current Tax	
Remove Cap	2024	Land Value	40,550	40,550	11%	Assessed	34,330	3,362.97	
Year Frozen		Improvements	273,842	271,533		Penalty	0		
Uncapped Value	0	Mobile Home	0	0	0	Exemption	1,000	-98.00	
TIF Project ID	0	Total Value	314,392	312,083	34,330	Total Taxable	33,330	3,265.00	
Assessment History									
Tax Year	Statement Number	Billed Owner	Tax Area	Total Value	Exemptions	Taxable Value	Billed Tax		
2025	2025-660104497	SAMARANI, ELIE SALIM	40	302,994	1000	32,330	3,167.00		
2024	2024-660104497	SAMARANI, ELIE SALIM	40	357,372	1000	38,311	3,681.00		
2023	2023-660104497	SAMARANI, ELIE SALIM	40	6,250	0	688	64.00		
2022	2022-660104497	SHAW HOMES OKLAHOMA INC	40	6,250	0	688	67.00		
2021	2021-660104497	STONE CREEK PROPERTIES LLC	40	6,250	0	688	67.00		



Rogers

Assessment Property Record Card for Tax Year 2026

Data provided by LISA DELOZIER County Assessor

Date 04/18/2026
 Time 10:15:20
 Page 2

Lot Data		Square-Foot - NBHD 1059 #1	
Lot Size	0	0	
Lot Count	1		
Units Buildable			
Non-Ag Acres	0.209		
Topography			
Street Access			
Utilities			
Amenities			0
			0
Method	Square-Foot		
Base Lot Value	9,104.00 x 5.30 = 48,251		
Factor Value			
Adjustments	0.8404		
Lot Value	40,550		



\\tsclient\T\ROB STUFF\2023-3-7\IMG_0017.JPG 3/7/2023

Residential Data	
Type	1 Single Family Residence
Condition	3 - Average
Quality	3 - Average
Architecture	
Style	100% One Story
Exterior Wall	85% Veneer, Masonry 15% Frame, Siding, Wood
Base/Total Area	2,030 / 2,030
Style	100% One Story
HVAC	100% Warmed & Cooled Air
Roof Cover	1 Composition Shingle
Area on Slab	2,030
Fixture/RghIn	/
Bed/F/H Bath	4 / 2.0 /
Basement Area	
Garage Type	470 Attached Garage - Finished
Remodel	
Year/Eff Age	2023 / 2

GRM Approach

GRM Code	
Gross Rent	0.00
Indicated Value	

Multiple Regression

MRA Code	
Adjusted R	
Indicated Value	

Direct Comparables

Selection Model	A Adam Test
Adjustment Model	1 2022 Residential
Comparables	
Indicated Value	

Cost Approach Manual : 01/2025

Base Cost	105.89	Total Misc Impr	+	3,227
Roofing Adj	+ 4.68	Garage Cost	+	19,044
Subfloor Adj	+ -2.19	Total RCN	=	279,431
Heat/Cool Adj	+ 12.64	Depreciation (2%)	-	5,589
Plumbing Adj	+ 5.66	Lump Sums	+	0
Basement Adj	+ 0.00	RCNLD	=	273,842
Adj Base Cost	= 126.68	Lot Value	+	40,550
Total Area	x 2,030	Indicated Value	=	314,392
Adjusted Cost	= 257,160	Value Per SqFt		154.87

Value Reconciliation

Selected Approach	Cost Approach		
Improvements	273,842		
Lot Value	40,550		
Indicated Value	314,392	154.87	Per SqFt
Agland Value			
Site Improvements			
Total Value	314,392	154.87	Total Value Per SqFt

Miscellaneous Improvements

Code	Description	Sketch ID	Size	Year	Units	Unit Cost	Depr	Value
PRCH	Slab Porch - Covered	156652	5x5		25	26.85		671
PRCH	Slab Porch - Covered	156653	16x6		96	26.63		2,556



Rogers
Assessment Property Record Card for Tax Year 2026

Data provided by LISA DELOZIER County Assessor

Date 04/18/2026
 Time 10:15:20
 Page 3

Sketch Image

660104497

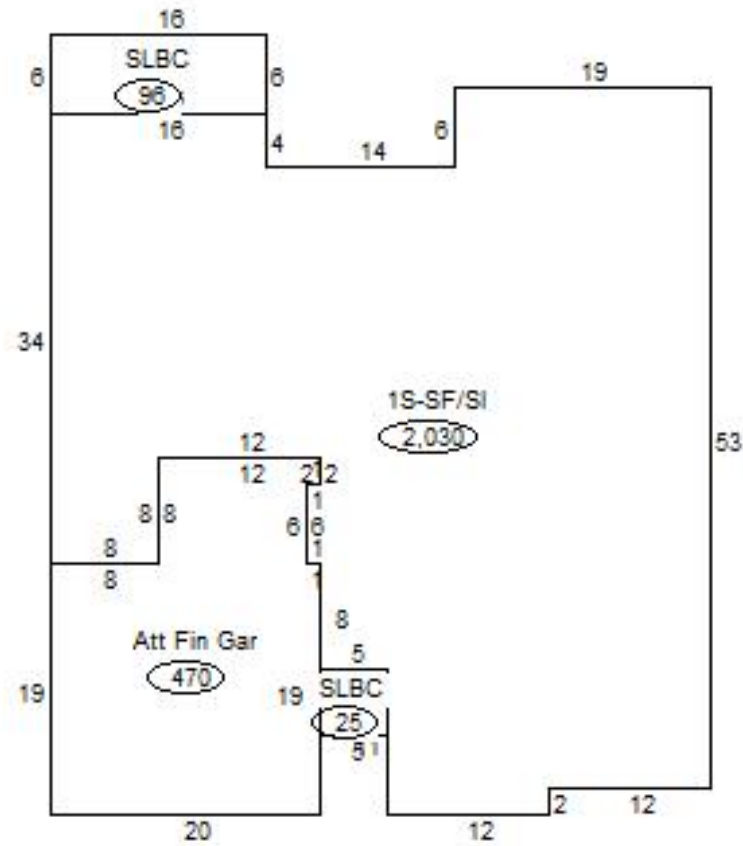

Sketch Vector Information

Sequence	Code	Type	Built Over	Scale	Section Label	Base Area	Multiplier	Total Area
1	R	1	Slab	20	1S-SF/SI	2,030	1.000	2,030
2	G	5		20	Att Fin Gar	470	1.000	470
3	M	PRCH		20	SLBC	25	1.000	25
4	M	PRCH		20	SLBC	96	1.000	96
Total Building Area						2,030		2,030