



Rogers

Assessment Property Record Card for Tax Year 2026

Data provided by LISA DELOZIER County Assessor

Date 04/18/2026
Time 10:18:38
Page 1

Assessment Data					Primary Image				
Account	660104598								
Parcel ID	00000-00-0-000296-002-0004								
Cadastral ID	05-21-16-18270								
Property Type	REAL - Real Property								
Property Class	URP	VI Area	1						
Tax Area	17 - CLAREMORE OT								
Name ID	341928								
HILDEBRAND, MICHAEL W & MARY J									
1508 WILDWOOD DR CLAREMORE OK 74017-0000									
Parcel Location									
Situs	01508 WILDWOOD DR								
Subdivision	ESTATES AT FOREST PARK III								
Lot/Block	0004 / 0002	Parcel Size	1 - Lots						
Sec/Twn/Rng	5 / 21 / 16 / 5								
Neighborhood	1154 - R-V01-NW CLAREMORE								
School District	S001 - CLAREMORE SCHOOLS								
Legal Description Lat/Long: 36.33518525 -95.62703592									
Building Permits									
LOT 4 BLOCK 2 ESTATES AT FOREST PARK III									
Number	Description	Opened	Closed	Amount					
R22 170	R23 NEW SFR 2776 SQ FT	04/2022	02/2023	205,000					
Exemptions									
Code	Type	Active	Maximum	Exemption					
H	Homestead	Yes	1,000	1,000					
Sale History									
Bk/Pg	Grantor	Date	Price	Code					
/	EXECUTIVE HOMES LLC	06/30/2023	470,000	YES					
/	NORTHLAKE ESTATES LLC	10/30/2020	930,000	WB					
Parcel Valuation									
Source	REAL	Fair Cash	Capped	Asmnt Level	Assessed	Levy Rate	92.430	Current Tax	
Remove Cap	2024	Land Value	157,147	146,562	11%	16,122	Assessed	51,779 4,785.93	
Year Frozen	2024	Improvements	347,568	324,156		35,657	Penalty	0	
Uncapped Value	0	Mobile Home	0	0		0	Exemption	1,000 -92.00	
TIF Project ID	0	Total Value	504,715	470,718		51,779	Total Taxable	50,779 4,694.00	
Assessment History									
Tax Year	Statement Number	Billed Owner	Tax Area	Total Value	Exemptions	Taxable Value	Billed Tax		
2025	2025-660104598	HILDEBRAND, MICHAEL W &	17	487,090	1000	50,779	4,694.00		
2024	2024-660104598	HILDEBRAND, MICHAEL W &	17	470,718	1000	50,779	4,693.00		
2023	2023-660104598	HILDEBRAND, MICHAEL W &	17	67,500	0	5,371	492.00		
2022	2022-660104598	EXECUTIVE HOMES LLC	17	46,500	0	5,115	473.00		
2021	2021-660104598	EXECUTIVE HOMES LLC	17	46,500	0	5,115	452.00		



Rogers

Assessment Property Record Card for Tax Year 2026

Data provided by LISA DELOZIER County Assessor

Date 04/18/2026
Time 10:18:38
Page 2

Lot Data		Square-Foot - NBHD 1154 #1	
Lot Size	0	0	
Lot Count	1		
Units Buildable			
Non-Ag Acres	0.2505		
Topography			
Street Access			
Utilities			
Amenities	LOT SIZE ADJUSTMENT		0
			0
Method	Square-Foot		
Base Lot Value	10,913.00 x 3.00 = 32,739		
Factor Value			
Adjustments	4.8000		
Lot Value	157,147		



\\tsclient\T\LOGAN\LOGAN RESIDENTIAL VI\2023-4-5\IMG_0029. 4/5/2023

Residential Data	
Type	1 Single Family Residence
Condition	3 - Average
Quality	4 - Good
Architecture	
Style	100% One Story
Exterior Wall	95% Veneer, Masonry 5% Veneer, Stone
Base/Total Area	2,137 / 2,137
Style	100% One Story
HVAC	100% Warmed & Cooled Air
Roof Cover	1 Composition Shingle
Area on Slab	2,137
Fixture/RghIn	/
Bed/F/H Bath	3 / 2.0 / 1.0
Basement Area	
Garage Type	616 Attached Garage - Finished
Remodel	
Year/Eff Age	2023 / 2

GRM Approach

GRM Code	
Gross Rent	0.00
Indicated Value	

Multiple Regression

MRA Code	
Adusted R	
Indicated Value	

Direct Comparables

Selection Model	A Adam Test
Adjustment Model	1 2022 Residential
Comparables	6
Indicated Value	455,470 Per SqFt

Value Reconciliation

Selected Approach	Cost Approach		
Improvements	347,568		
Lot Value	157,147		
Indicated Value	504,715	236.18	Per SqFt
Agland Value			
Site Improvements			
Total Value	504,715	236.18	Total Value Per SqFt

Cost Approach Manual : 01/2025

Base Cost	115.68	Total Misc Impr	+	15,624
Roofing Adj	+ 5.96	Garage Cost	+	35,839
Subfloor Adj	+ -4.62	Total RCN	=	354,661
Heat/Cool Adj	+ 16.31	Depreciation (2%)	-	7,093
Plumbing Adj	+ 8.55	Lump Sums	+	0
Basement Adj	+ 0.00	RCNLD	=	347,568
Adj Base Cost	= 141.88	Lot Value	+	157,147
Total Area	x 2,137	Indicated Value	=	504,715
Adjusted Cost	= 303,198	Value Per SqFt		236.18

Miscellaneous Improvements

Code	Description	Sketch ID	Size	Year	Units	Unit Cost	Depr	Value
PRCH	Slab Porch - Covered	156328	6x5		30	33.10		993
PRCH	Slab Porch - Covered	156329	19x13		247	32.11		7,931
FPPF	Fireplace - Prefabricated			2023	1	6,700.26		6,700



Rogers

Assessment Property Record Card for Tax Year 2026

Data provided by LISA DELOZIER County Assessor

Date 04/18/2026
 Time 10:18:38
 Page 3

Sketch Image

660104598

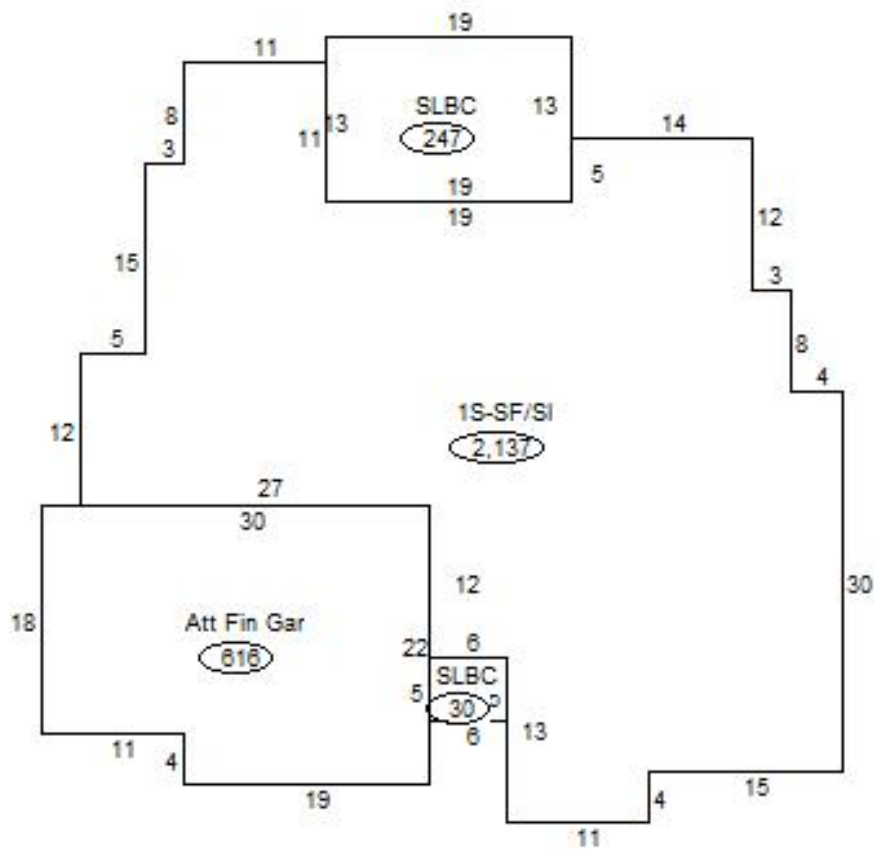

Sketch Vector Information

Sequence	Code	Type	Built Over	Scale	Section Label	Base Area	Multiplier	Total Area
1	R	1	Slab	20	1S-SF/SI	2,137	1.000	2,137
2	G	5		20	Att Fin Gar	616	1.000	616
3	M	PRCH		20	SLBC	30	1.000	30
4	M	PRCH		20	SLBC	247	1.000	247
Total Building Area						2,137		2,137