



Rogers

Assessment Property Record Card for Tax Year 2026

Data provided by LISA DELOZIER County Assessor

Date 04/18/2026
 Time 10:27:02
 Page 1

Assessment Data					Primary Image				
Account	660105479								
Parcel ID	000000-0001-008-0-000-00								
Cadastral ID	27-21-14-07080								
Property Type	REAL - Real Property								
Property Class	URP	VI Area	4						
Tax Area	40 - OWASSO CITY								
Name ID	348402								
ROYCE, TAMISON E & MICHAEL A									
14508 E 80TH CT N OWASSO OK 74055-0000									
Parcel Location									
Situs	14508 E 80TH CT N								
Subdivision	PRESLEY HOLLOW								
Lot/Block	0008 / 0001	Parcel Size	1 - Lots						
Sec/Twn/Rng	27 / 21 / 14 / 5								
Neighborhood	1087 - R-V04-SW OWASSO								
School District	S021 - OWASSO SCHOOLS								
Legal Description Lat/Long: 36.26994402 -95.81082447									
LOT 8 BLOCK 1 PRESLEY HOLLOW									
Building Permits									
Number	Description	Opened	Closed	Amount					
R25 234X	NEW SFR 2472 SQ FT	03/2025	12/2025	231,150					
Exemptions									
Code	Type	Active	Maximum	Exemption					
H	Homestead	Yes	1,000	1,000					
Sale History									
Bk/Pg	Grantor	Date	Price	Code					
/	EXECUTIVE HOMES LLC	10/03/2025	519,000	15					
/	BLUE CHIP LAND CO LLC	02/12/2025	0	4					
Parcel Valuation									
Source	REAL	Fair Cash	Capped	Asmnt Level	Assessed	Levy Rate	97.960	Current Tax	
Remove Cap	2026	Land Value	130,194	130,194	11%	14,321	Assessed	57,090 5,592.54	
Year Frozen		Improvements	388,806	388,806		42,769	Penalty	0	
Uncapped Value	388,806	Mobile Home	0	0		0	Exemption	1,000 -98.00	
TIF Project ID	0	Total Value	519,000	519,000		57,090	Total Taxable	56,090 5,495.00	
Assessment History									
Tax Year	Statement Number	Billed Owner	Tax Area	Total Value	Exemptions	Taxable Value	Billed Tax		
2025	2025-660105479	EXECUTIVE HOMES LLC	40	3,394	0	373	37.00		
2024	2024-660105479	BLUE CHIP LAND CO LLC	40	3,394	0	373	36.00		
2023	2023-660105479	BLUE CHIP LAND CO LLC	40	3,394	0	373	35.00		
2022	2022-660105479	BLUE CHIP LAND CO LLC	40	3,394	0	373	37.00		



Rogers

Assessment Property Record Card for Tax Year 2026

Data provided by LISA DELOZIER County Assessor

Date 04/18/2026
Time 10:27:02
Page 2

Lot Data		Square-Foot - NBHD 1087 #1	
Lot Size	0	0	
Lot Count	1		
Units Buildable			
Non-Ag Acres	0.2009		
Topography			
Street Access			
Utilities			
Amenities		0	
		0	
Method	Square-Foot		
Base Lot Value	8,751.00 x 6.00 = 52,506		
Factor Value			
Adjustments	2.4796		
Lot Value	130,194		

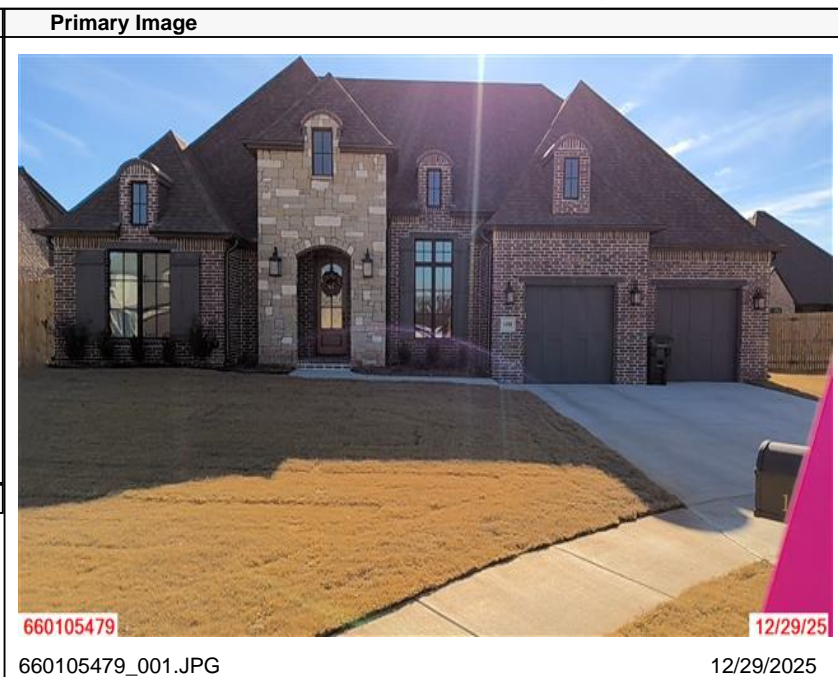

660105479 12/29/25
660105479_001.JPG 12/29/2025

Residential Data	
Type	1 Single Family Residence
Condition	4 - Good
Quality	4 - Good
Architecture	
Style	100% One Story
Exterior Wall	95% Veneer, Masonry 5% Veneer, Stone
Base/Total Area	2,463 / 2,463
Style	100% One Story
HVAC	100% Warmed & Cooled Air
Roof Cover	1 Composition Shingle
Area on Slab	2,463
Fixture/RghIn	/
Bed/F/H Bath	3 / 2.0 / 1.0
Basement Area	
Garage Type	620 Attached Garage - Finished
Remodel	
Year/Eff Age	2025 / 1

GRM Approach	
GRM Code	
Gross Rent	0.00
Indicated Value	

Multiple Regression	
MRA Code	
Adjusted R	
Indicated Value	

Direct Comparables	
Selection Model	A Adam Test
Adjustment Model	1 2022 Residential
Comparables	
Indicated Value	

Cost Approach		Manual : 01/2025	
Base Cost	113.55	Total Misc Impr	+ 15,542
Roofing Adj	+ 5.83	Garage Cost	+ 36,041
Subfloor Adj	+ -4.60	Total RCN	= 392,733
Heat/Cool Adj	+ 16.31	Depreciation (1%)	- 3,927
Plumbing Adj	+ 7.42	Lump Sums	+ 0
Basement Adj	+ 0.00	RCNLD	= 388,806
Adj Base Cost	= 138.51	Lot Value	+ 130,194
Total Area	x 2,463	Indicated Value	= 519,000
Adjusted Cost	= 341,150	Value Per SqFt	210.72

Value Reconciliation			
Selected Approach	Cost Approach		
Improvements	388,806		
Lot Value	130,194		
Indicated Value	519,000	210.72	Per SqFt
Agland Value			
Site Improvements			
Total Value	519,000	210.72	Total Value Per SqFt

Miscellaneous Improvements								
Code	Description	Sketch ID	Size	Year	Units	Unit Cost	Depr	Value
PRCH	Porch	188179	87		87	32.92		2,864
PATC	Patio - Covered	188180	28x11		308	19.41		5,978
FPPF	Fireplace - Prefabricated		1	2025	1	6,700.26		6,700



Rogers

Assessment Property Record Card for Tax Year 2026

Data provided by LISA DELOZIER County Assessor

Date 04/18/2026
 Time 10:27:02
 Page 3

Sketch Image

660105479

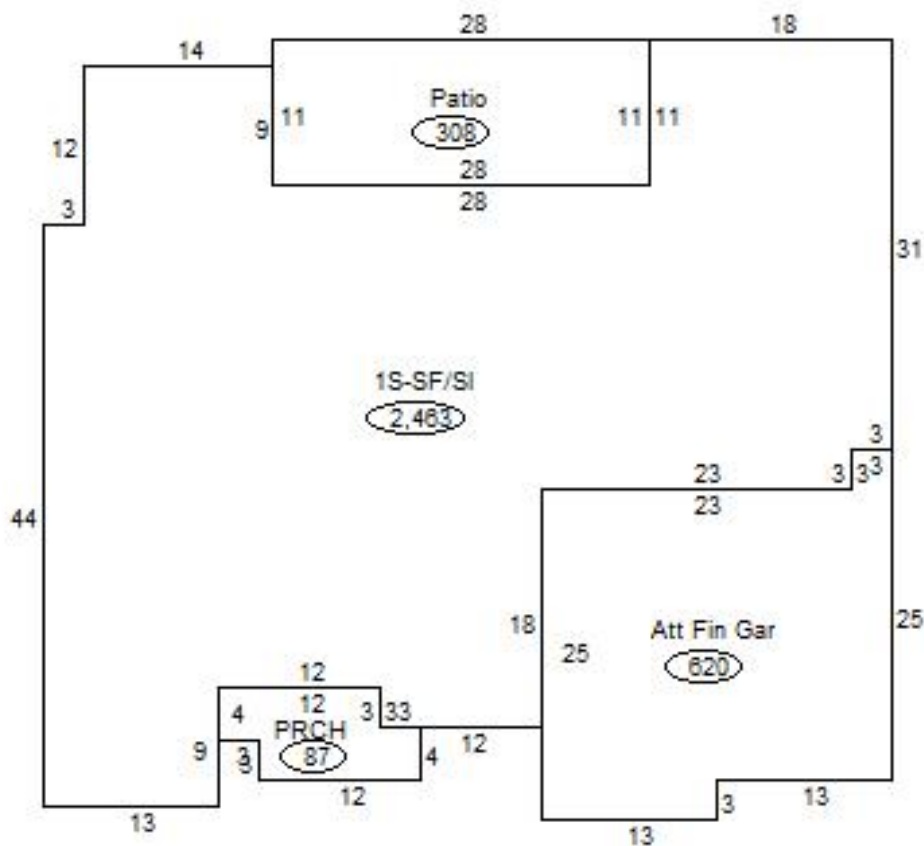

Sketch Vector Information

Sequence	Code	Type	Built Over	Scale	Section Label	Base Area	Multiplier	Total Area
1	R	1	Slab	20	1S-SF/Sl	2,463	1.000	2,463
2	G	5		20	Att Fin Gar	620	1.000	620
3	M	PRCH		20	PRCH	87	1.000	87
4	M	PATC		20	Patio	308	1.000	308
Total Building Area						2,463		2,463