



Rogers

Assessment Property Record Card for Tax Year 2026

Data provided by LISA DELOZIER County Assessor

Date 04/18/2026
 Time 10:31:15
 Page 1

Assessment Data				Primary Image						
Account	660105614									
Parcel ID	000000-0009-009-0-000-00									
Cadastral ID	27-21-14-08430									
Property Type	REAL - Real Property									
Property Class	URP	VI Area	4							
Tax Area	40 - OWASSO CITY									
Name ID	345747									
KLOKER, LOGAN BROOKE & LANCE THOMAS										
7711 N 147TH E AVE OWASSO OK 74055-0000										
Parcel Location										
Situs	07711 N 147TH E AVE									
Subdivision	PRESLEY HOLLOW									
Lot/Block	0009 / 0009	Parcel Size	1 - Lots							
Sec/Twn/Rng	27 / 21 / 14 / 5									
Neighborhood	1087 - R-V04-SW OWASSO									
School District	S021 - OWASSO SCHOOLS									
Legal Description Lat/Long: 36.26563471 -95.80916438				Building Permits						
LOT 9 BLOCK 9 PRESLEY HOLLOW				Number	Description	Opened	Closed	Amount		
				R21 0610X	R23- NEW 2541 SQ FT SFR	08/2021	08/2022	175,395		
Exemptions				Sale History						
Code	Type	Active	Maximum	Exemption	Bk/Pg	Grantor	Date	Price	Code	
					/	KELLEY, BRYCE & DULCE	10/21/2024	472,500	YES	
					/	EXECUTIVE HOMES LLC	04/22/2022	390,500	YES	
					/	BLUE CHIP LAND CO LLC	08/17/2021	0	WB	
Parcel Valuation										
Source	REAL		Fair Cash	Capped	Asmnt Level	Assessed	Levy Rate	97.960	Current Tax	
Remove Cap	2025	Land Value	74,210	74,210	11%	8,163	Assessed	54,574	5,346.07	
Year Frozen		Improvements	423,115	421,915		46,411	Penalty	0		
Uncapped Value	0	Mobile Home	0	0		0	Exemption	0	0.00	
TIF Project ID	0	Total Value	497,325	496,125		54,574	Total Taxable	54,574	5,346.00	
Assessment History										
Tax Year	Statement Number	Billed Owner			Tax Area	Total Value	Exemptions	Taxable Value	Billed Tax	
2025	2025-660105614	KLOKER, LOGAN BROOKE &			40	472,500	0	51,975	5,091.00	
2024	2024-660105614	KELLEY, BRYCE & DULCE			40	467,302	0	45,103	4,333.00	
2023	2023-660105614	KELLEY, BRYCE & DULCE			40	390,500	0	42,955	4,025.00	
2022	2022-660105614	KELLEY, BRYCE & DULCE			40	3,394	0	373	37.00	



Rogers

Assessment Property Record Card for Tax Year 2026

Data provided by LISA DELOZIER County Assessor

Date 04/18/2026
 Time 10:31:15
 Page 2

Lot Data		Square-Foot - NBHD 1087 #1	
Lot Size	0	0	
Lot Count	1		
Units Buildable			
Non-Ag Acres	0.244		
Topography			
Street Access			
Utilities			
Amenities			0
			0
Method	Square-Foot		
Base Lot Value	10,627.00 x 5.84 = 62,069		
Factor Value			
Adjustments	1.1956		
Lot Value	74,210		



\\tsclient\X\Rob Stuff\ROBS NEW CONST\2022-8-15\IMG_0013.JF 8/15/2022

Residential Data	
Type	1 Single Family Residence
Condition	4 - Good
Quality	4 - Good
Architecture	
Style	100% One Story
Exterior Wall	95% Veneer, Masonry 5% Veneer, Stone
Base/Total Area	2,803 / 2,803
Style	100% One Story
HVAC	100% Warmed & Cooled Air
Roof Cover	1 Composition Shingle
Area on Slab	2,803
Fixture/RghIn	/
Bed/F/H Bath	4 / 3.0 /
Basement Area	
Garage Type	610 Attached Garage - Finished
Remodel	
Year/Eff Age	2022 / 2

GRM Approach

GRM Code	
Gross Rent	0.00
Indicated Value	

Multiple Regression

MRA Code	1	Test
Adusted R	0.8445	
Indicated Value	417,960	149.11 Per SqFt

Direct Comparables

Selection Model	A	Adam Test
Adjustment Model	1	2022 Residential
Comparables	1	
Indicated Value	386,120	Per SqFt

Value Reconciliation

Selected Approach	Cost Approach		
Improvements	423,115		
Lot Value	74,210		
Indicated Value	497,325	177.43	Per SqFt
Agland Value			
Site Improvements			
Total Value	497,325	177.43	Total Value Per SqFt

Cost Approach		Manual : 01/2025	
Base Cost	110.62	Total Misc Impr	+ 16,685
Roofing Adj	+ 5.71	Garage Cost	+ 35,539
Subfloor Adj	+ -4.37	Total RCN	= 431,750
Heat/Cool Adj	+ 16.31	Depreciation (2%)	- 8,635
Plumbing Adj	+ 7.13	Lump Sums	+ 0
Basement Adj	+ 0.00	RCNLD	= 423,115
Adj Base Cost	= 135.40	Lot Value	+ 74,210
Total Area	x 2,803	Indicated Value	= 497,325
Adjusted Cost	= 379,526	Value Per SqFt	177.43

Miscellaneous Improvements

Code	Description	Sketch ID	Size	Year	Units	Unit Cost	Depr	Value
PRCH	Slab Porch - Covered	154706	281		281	32.00		8,992
PRCH	Slab Porch - Covered	154707	6x5		30	33.10		993
FPPF	Fireplace - Prefabricated			1	1	6,700.26		6,700



Rogers

Assessment Property Record Card for Tax Year 2026

Data provided by LISA DELOZIER County Assessor

Date 04/18/2026

Time 10:31:15

Page 3

Sketch Image

660105614

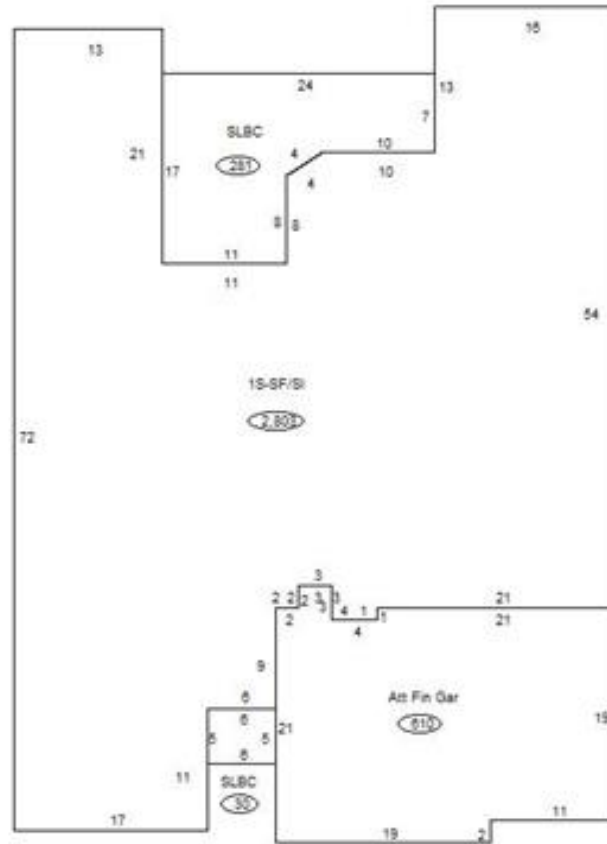

Sketch Vector Information

Sequence	Code	Type	Built Over	Scale	Section Label	Base Area	Multiplier	Total Area
1	R	1	Slab	13	1S-SF/SI	2,803	1.000	2,803
2	G	5		13	Att Fin Gar	610	1.000	610
3	M	PRCH		13	SLBC	281	1.000	281
4	M	PRCH		13	SLBC	30	1.000	30
Total Building Area						2,803		2,803