



Rogers

Assessment Property Record Card for Tax Year 2026

Data provided by LISA DELOZIER County Assessor

Date 04/18/2026
Time 10:31:28
Page 1

Assessment Data					Primary Image														
Account 660105621 Parcel ID 000000-0009-016-0-000-00 Cadastral ID 27-21-14-08500 Property Type REAL - Real Property Property Class URP VI Area 4 Tax Area 40 - OWASSO CITY Name ID 345177 KUBALA FAMILY REVOCABLE TRUST KATHRYN M KUBALA-TRUSTEE 7712 N 150TH E CT OWASSO OK 74055-0000 Parcel Location Situs 07712 N 150TH E CT Subdivision PRESLEY HOLLOW Lot/Block 0016 / 0009 Parcel Size 1 - Lots Sec/Twn/Rng 27 / 21 / 14 / 5 Neighborhood 1087 - R-V04-SW OWASSO School District S021 - OWASSO SCHOOLS					 <p>\\tsclient\T\ROB STUFF\2023-3-1\IMG_0010.JPG 3/1/2023</p>														
Legal Description Lat/Long: 36.26598518 -95.80752341																			
LOT 16 BLOCK 9 PRESLEY HOLLOW					Building Permits <table border="1"> <thead> <tr> <th>Number</th> <th>Description</th> <th>Opened</th> <th>Closed</th> <th>Amount</th> </tr> </thead> <tbody> <tr> <td>R22 220</td> <td>R23 NEW SFR 2941 SQ FT</td> <td>03/2022</td> <td>03/2023</td> <td>161,755</td> </tr> </tbody> </table>					Number	Description	Opened	Closed	Amount	R22 220	R23 NEW SFR 2941 SQ FT	03/2022	03/2023	161,755
Number	Description	Opened	Closed	Amount															
R22 220	R23 NEW SFR 2941 SQ FT	03/2022	03/2023	161,755															
Exemptions					Sale History														
Code	Type	Active	Maximum	Exemption	Bk/Pg	Grantor	Date	Price	Code										
H	Homestead	Yes	1,000	1,000	/	HIKES, SCOTT B & SARA E	08/28/2024	595,000	YES										
					/	EXECUTIVE HOMES LLC	02/10/2023	550,000	YES										
					/	BLUE CHIP LAND CO LLC	07/12/2022	0	WB										
Parcel Valuation																			
Source	REAL		Fair Cash	Capped	Asmnt Level	Assessed	Levy Rate	97.960	Current Tax										
Remove Cap	2025		Land Value	165,482	165,482	11%	18,203	Assessed	67,413 6,603.78										
Year Frozen			Improvements	447,729	447,368		49,210	Penalty	0										
Uncapped Value	0		Mobile Home	0	0		0	Exemption	1,000 -98.00										
TIF Project ID	0		Total Value	613,211	612,850		67,413	Total Taxable	66,413 6,506.00										
Assessment History																			
Tax Year	Statement Number	Billed Owner			Tax Area	Total Value	Exemptions	Taxable Value	Billed Tax										
2025	2025-660105621	KUBALA FAMILY REVOCABLE TRUST			40	595,000	1000	64,450	6,314.00										
2024	2024-660105621	KUBALA FAMILY REVOCABLE TRUST			40	551,172	1000	59,629	5,729.00										
2023	2023-660105621	HIKES, SCOTT B & SARA E			40	3,394	0	373	35.00										
2022	2022-660105621	EXECUTIVE HOMES LLC			40	3,394	0	373	37.00										



Rogers

Assessment Property Record Card for Tax Year 2026

Data provided by LISA DELOZIER County Assessor

Date 04/18/2026
Time 10:31:28
Page 2

Lot Data		Square-Foot - NBHD 1087 #1	
Lot Size	0	0	
Lot Count	1		
Units Buildable			
Non-Ag Acres	0.2187		
Topography			
Street Access			
Utilities			
Amenities			0
			0
Method	Square-Foot		
Base Lot Value	9,525.00 x 6.00 = 57,150		
Factor Value			
Adjustments	2.8956		
Lot Value	165,482		



\\tsclient\T\ROB STUFF\2023-3-1\IMG_0010.JPG 3/1/2023

Residential Data	
Type	1 Single Family Residence
Condition	4 - Good
Quality	4.5 - Good
Architecture	
Style	100% 1 1/2 Story Finished
Exterior Wall	95% Veneer, Masonry 5% Veneer, Stone
Base/Total Area	2,151 / 2,988
Style	100% 1 1/2 Story Finished
HVAC	100% Warmed & Cooled Air
Roof Cover	1 Composition Shingle
Area on Slab	2,151
Fixture/RghIn	/
Bed/F/H Bath	4 / 3.0 / 1.0
Basement Area	
Garage Type	669 Attached Garage - Finished
Remodel	
Year/Eff Age	2023 / 2

GRM Approach

GRM Code	
Gross Rent	0.00
Indicated Value	

Multiple Regression

MRA Code	
Adusted R	
Indicated Value	

Direct Comparables

Selection Model	A Adam Test
Adjustment Model	1 2022 Residential
Comparables	
Indicated Value	

Value Reconciliation

Selected Approach	Cost Approach		
Improvements	447,729		
Lot Value	165,482		
Indicated Value	613,211	205.22	Per SqFt
Agland Value			
Site Improvements			
Total Value	613,211	205.22	Total Value Per SqFt

Cost Approach Manual : 01/2025

Base Cost	107.64	Total Misc Impr	+	13,532
Roofing Adj	+ 4.57	Garage Cost	+	41,030
Subfloor Adj	+ -3.32	Total RCN	=	456,866
Heat/Cool Adj	+ 17.38	Depreciation (2%)	-	9,137
Plumbing Adj	+ 8.37	Lump Sums	+	0
Basement Adj	+ 0.00	RCNLD	=	447,729
Adj Base Cost	= 134.64	Lot Value	+	165,482
Total Area	x 2,988	Indicated Value	=	613,211
Adjusted Cost	= 402,304	Value Per SqFt		205.22

Miscellaneous Improvements

Code	Description	Sketch ID	Size	Year	Units	Unit Cost	Depr	Value
PRCH	Slab Porch - Covered	156493	9x5		45	36.52		1,643
PRCH	Slab Porch - Covered	156494	339		339	35.07		11,889



Rogers

Assessment Property Record Card for Tax Year 2026

Data provided by LISA DELOZIER County Assessor

Date 04/18/2026

Time 10:31:28

Page 3

Sketch Image

660105621

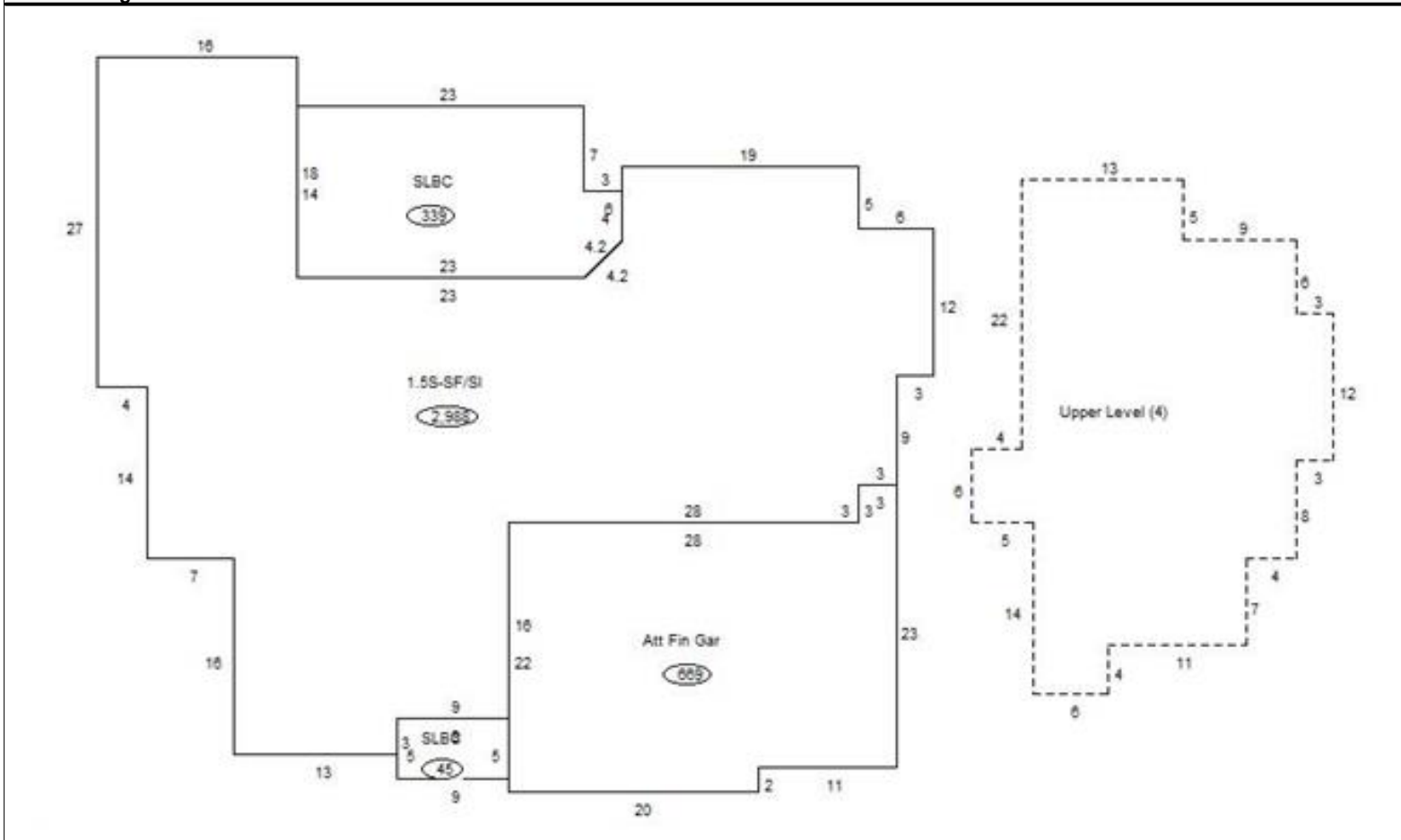

Sketch Vector Information

Sequence	Code	Type	Built Over	Scale	Section Label	Base Area	Multiplier	Total Area
1	G	5		13	Att Fin Gar	669	1.000	669
2	M	PRCH		13	SLBC	45	1.000	45
3	M	PRCH		13	SLBC	339	1.000	339
4	R	5	Slab	13	1.5S-SF/SI	2,151	1.389	2,988
5	U	^UL		13	Upper Level (4)	837	1.000	837
Total Building Area						2,151		2,988