



Rogers

Assessment Property Record Card for Tax Year 2026

Data provided by LISA DELOZIER County Assessor

Date 04/18/2026
Time 10:31:58
Page 1

Assessment Data					Primary Image				
Account	660105637				<p>06/16/2023</p> <p>\\tsclient\T\ROB STUFF\2023-6-16\IMG_0001.JPG 6/16/2023</p>				
Parcel ID	000000-0010-007-0-000-00								
Cadastral ID	27-21-14-08660								
Property Type	REAL - Real Property								
Property Class	URP	VI Area	4						
Tax Area	40 - OWASSO CITY								
Name ID	343219								
THACKER LIVING TRUST									
14808 E 77TH PL N OWASSO OK 74055-0000									
Parcel Location									
Situs	14808 E 77TH PL N								
Subdivision	PRESLEY HOLLOW								
Lot/Block	0007 / 0010	Parcel Size	1 - Lots						
Sec/Twn/Rng	27 / 21 / 14 / 5								
Neighborhood	1087 - R-V04-SW OWASSO								
School District	S021 - OWASSO SCHOOLS								
Legal Description Lat/Long: 36.26520685 -95.80785458									
Building Permits									
LOT 7 BLOCK 10 PRESLEY HOLLOW									
Number	Description	Opened	Closed	Amount					
R22	R23 NEW SFR	08/2022	06/2023						
Exemptions									
Code	Type	Active	Maximum	Exemption					
H	Homestead	Yes	1,000	1,000					
Sale History									
Bk/Pg	Grantor	Date	Price	Code					
/	THACKER, JOHN H &	11/02/2023	0	4					
/	EXECUTIVE HOMES LLC	05/01/2023	440,000	YES					
/	BLUE CHIP LAND CO LLC	07/12/2022	0	WB					
Parcel Valuation									
Source	REAL	Fair Cash	Capped	Asmnt Level	Assessed	Levy Rate	97.960	Current Tax	
Remove Cap	2024	Land Value	90,476	90,476	11%	9,952	Assessed	46,872 4,591.58	
Year Frozen		Improvements	340,784	335,633		36,920	Penalty	0	
Uncapped Value	0	Mobile Home	0	0		0	Exemption	1,000 -98.00	
TIF Project ID	0	Total Value	431,260	426,109		46,872	Total Taxable	45,872 4,494.00	
Assessment History									
Tax Year	Statement Number	Billed Owner	Tax Area	Total Value	Exemptions	Taxable Value	Billed Tax		
2025	2025-660105637	THACKER LIVING TRUST	40	413,699	1000	44,507	4,360.00		
2024	2024-660105637	THACKER LIVING TRUST	40	440,456	1000	47,450	4,559.00		
2023	2023-660105637	THACKER, JOHN H &	40	3,394	0	373	35.00		
2022	2022-660105637	EXECUTIVE HOMES LLC	40	3,394	0	373	37.00		



Rogers

Assessment Property Record Card for Tax Year 2026

Data provided by LISA DELOZIER County Assessor

Date 04/18/2026
 Time 10:31:58
 Page 2

Lot Data		Square-Foot - NBHD 1087 #1	
Lot Size	0	0	
Lot Count	1		
Units Buildable			
Non-Ag Acres	0.1953		
Topography			
Street Access			
Utilities			
Amenities			0
			0
Method	Square-Foot		
Base Lot Value	8,505.00 x 6.00 = 51,030		
Factor Value			
Adjustments	1.7730		
Lot Value	90,476		



\\tsclient\T\ROB STUFF\2023-6-16\IMG_0001.JPG 6/16/2023

Residential Data	
Type	1 Single Family Residence
Condition	4 - Good
Quality	4 - Good
Architecture	
Style	100% One Story
Exterior Wall	95% Veneer, Masonry 5% Veneer, Stone
Base/Total Area	2,073 / 2,073
Style	100% One Story
HVAC	100% Warmed & Cooled Air
Roof Cover	1 Composition Shingle
Area on Slab	2,073
Fixture/RghIn	/
Bed/F/H Bath	4 / 2.0 /
Basement Area	
Garage Type	710 Attached Garage - Finished
Remodel	
Year/Eff Age	2023 / 2

GRM Approach

GRM Code	
Gross Rent	0.00
Indicated Value	

Multiple Regression

MRA Code	
Adjusted R	
Indicated Value	

Direct Comparables

Selection Model	A Adam Test
Adjustment Model	1 2022 Residential
Comparables	
Indicated Value	

Value Reconciliation

Selected Approach	Cost Approach		
Improvements	340,784		
Lot Value	90,476		
Indicated Value	431,260	208.04	Per SqFt
Agland Value			
Site Improvements			
Total Value	431,260	208.04	Total Value Per SqFt

Cost Approach		Manual : 01/2025	
Base Cost	116.42	Total Misc Impr	+ 14,373
Roofing Adj	+ 6.01	Garage Cost	+ 40,513
Subfloor Adj	+ -4.62	Total RCN	= 347,739
Heat/Cool Adj	+ 16.31	Depreciation (2%)	- 6,955
Plumbing Adj	+ 7.15	Lump Sums	+ 0
Basement Adj	+ 0.00	RCNLD	= 340,784
Adj Base Cost	= 141.27	Lot Value	+ 90,476
Total Area	x 2,073	Indicated Value	= 431,260
Adjusted Cost	= 292,853	Value Per SqFt	208.04

Miscellaneous Improvements

Code	Description	Sketch ID	Size	Year	Units	Unit Cost	Depr	Value
PRCH	Slab Porch - Covered	157446	6x6		36	33.08		1,191
PRCH	Slab Porch - Covered	157447	201		201	32.25		6,482
FPPF	Fireplace - Prefabricated			2023	1	6,700.26		6,700



Rogers

Assessment Property Record Card for Tax Year 2026

Data provided by LISA DELOZIER County Assessor

Date 04/18/2026
 Time 10:31:58
 Page 3

Sketch Image

660105637

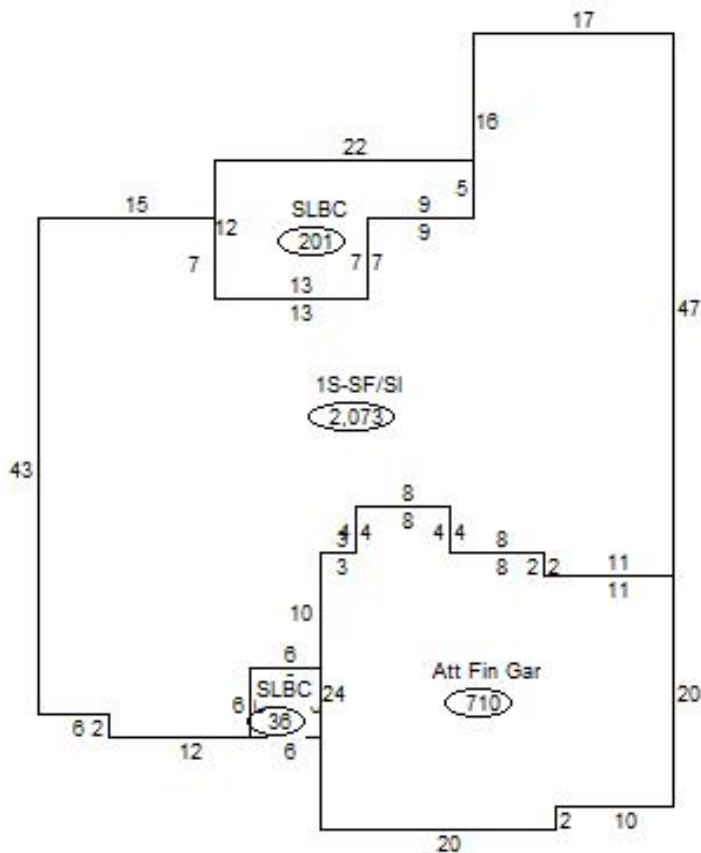

Sketch Vector Information

Sequence	Code	Type	Built Over	Scale	Section Label	Base Area	Multiplier	Total Area
1	R	1	Slab	20	1S-SF/SI	2,073	1.000	2,073
2	G	5		20	Att Fin Gar	710	1.000	710
3	M	PRCH		20	SLBC	36	1.000	36
4	M	PRCH		20	SLBC	201	1.000	201
Total Building Area						2,073		2,073