



Rogers

Assessment Property Record Card for Tax Year 2026

Data provided by LISA DELOZIER County Assessor

Date 04/18/2026
 Time 10:33:08
 Page 1

Assessment Data				Primary Image						
Account	660105677									
Parcel ID	000000-0001-001-0-000-00									
Cadastral ID	01-20-14-04010									
Property Type	REAL - Real Property									
Property Class	RRP	VI Area	3							
Tax Area	3 - OWASSO RURAL/NO FIRE									
Name ID	345954									
WILLIAMS, MICHAEL & NANCY L										
6302 N BLUE SAGE DR OWASSO OK 74055-0000										
Parcel Location										
Situs	06302 N BLUE SAGE DR									
Subdivision	HIGHLAND MEADOWS AT STONE CANYON									
Lot/Block	0001 / 0001	Parcel Size	1 - Lots							
Sec/Twn/Rng	1 / 20 / 14 / 5									
Neighborhood	1041 - R-V01,4-SW OWASSO									
School District	S021 - OWASSO SCHOOLS									
Legal Description Lat/Long: 36.24508845 -95.77192919				Building Permits						
LOT 1 BLOCK 1 HIGHLAND MEADOWS AT STONE CANYON				Number	Description	Opened	Closed	Amount		
				R23 204	R24 NEW SFR 4293 SQ FT	09/2023	05/2024	675,000		
Exemptions				Sale History						
Code	Type	Active	Maximum	Exemption	Bk/Pg	Grantor	Date	Price	Code	
					/	HILL HOUSE ENTERPRISES LLC	12/04/2024	1,035,000	YES	
					/	C.A.B.O. DEVELOPMENT COMPANY LI	12/20/2022	135,000	YES	
Parcel Valuation										
Source	REAL		Fair Cash	Capped	Asmnt Level	Assessed	Levy Rate	97.960	Current Tax	
Remove Cap	2025		Land Value	297,723	297,723	11%	Assessed	118,046	11,563.79	
Year Frozen			Improvements	775,418	775,418		Penalty	0		
Uncapped Value	0		Mobile Home	0	0	0	Exemption	0	0.00	
TIF Project ID	0		Total Value	1,073,141	1,073,141	118,046	Total Taxable	118,046	11,564.00	
Assessment History										
Tax Year	Statement Number	Billed Owner			Tax Area	Total Value	Exemptions	Taxable Value	Billed Tax	
2025	2025-660105677	WILLIAMS, MICHAEL & NANCY L			3	1,035,000	0	113,850	11,153.00	
2024	2024-660105677	HILL HOUSE ENTERPRISES LLC			3	5,090	0	560	54.00	
2023	2023-660105677	HILL HOUSE ENTERPRISES LLC			3	5,090	0	560	52.00	
2022	2022-660105677	C.A.B.O. DEVELOPMENT COMPANY LLC			3	5,090	0	560	55.00	



Rogers

Assessment Property Record Card for Tax Year 2026

Data provided by LISA DELOZIER County Assessor

Date 04/18/2026
Time 10:33:08
Page 2

Lot Data		Square-Foot - NBHD 1041 #1	
Lot Size	0	0	
Lot Count	1		
Units Buildable			
Non-Ag Acres	0.7311		
Topography			
Street Access			
Utilities			
Amenities	LOT TYPE		0
	GATED		0
Method	Square-Foot		
Base Lot Value	31,848.00 x 4.35 = 138,539		
Factor Value			
Adjustments	2.1490		
Lot Value	297,723		



660105677_001.JPG 5/29/2024

Residential Data	
Type	1 Single Family Residence
Condition	5 - Very Good
Quality	5.5 - Very Good
Architecture	TRAD TRADITIONAL
Style	100% 1 1/2 Story Finished
Exterior Wall	90% Veneer, Masonry 10% Frame, Siding, Wood
Base/Total Area	3,177 / 4,315
Style	100% 1 1/2 Story Finished
HVAC	100% Warmed & Cooled Air
Roof Cover	1 Composition Shingle
Area on Slab	3,177
Fixture/RghIn	/
Bed/F/H Bath	4 / 4.0 / 1.0
Basement Area	
Garage Type	1,073 Attached Garage - Finished
Remodel	
Year/Eff Age	2024 / 1

GRM Approach	
GRM Code	
Gross Rent	0.00
Indicated Value	

Multiple Regression			
MRA Code	AO3	Residential	
Adusted R	0.8747		
Indicated Value	967,036	224.11	Per SqFt

Direct Comparables			
Selection Model	A	Adam Test	
Adjustment Model	1	2022 Residential	
Comparables	6		
Indicated Value	930,980		Per SqFt

Cost Approach				Manual : 01/2025			
Base Cost	112.69	Total Misc Impr	+ 85,900				
Roofing Adj	+ 5.09	Garage Cost	+ 87,814				
Subfloor Adj	+ -4.79	Total RCN	= 783,251				
Heat/Cool Adj	+ 20.10	Depreciation (1%)	- 7,833				
Plumbing Adj	+ 8.17	Lump Sums	+ 0				
Basement Adj	+ 0.00	RCNLD	= 775,418				
Adj Base Cost	= 141.26	Lot Value	+ 297,723				
Total Area	x 4,315	Indicated Value	= 1,073,141				
Adjusted Cost	= 609,537	Value Per SqFt	248.70				

Value Reconciliation			
Selected Approach	Cost Approach		
Improvements	775,418		
Lot Value	297,723		
Indicated Value	1,073,141	248.70	Per SqFt
Agland Value			
Site Improvements			
Total Value	1,073,141	248.70	Total Value Per SqFt

Miscellaneous Improvements								
Code	Description	Sketch ID	Size	Year	Units	Unit Cost	Depr	Value
PRCH	Slab Porch - Covered	160237	709		709	42.46		30,104
PRCH	Slab Porch - Covered	160238	958		958	41.58		39,834
FPPF	Fireplace - Prefabricated			2024	1	8,258.46		8,258
ODFP	Outdoor Fireplace/Firepit			2024	1	7,704.33		7,704



Rogers

Assessment Property Record Card for Tax Year 2026

Data provided by LISA DELOZIER County Assessor

Date 04/18/2026

Time 10:33:08

Page 3

Sketch Image

660105677

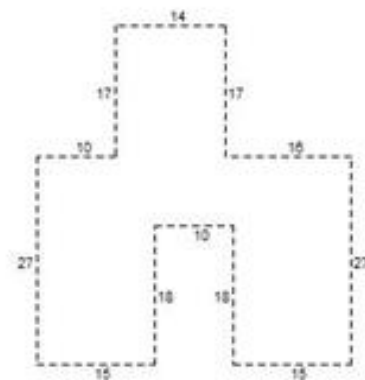
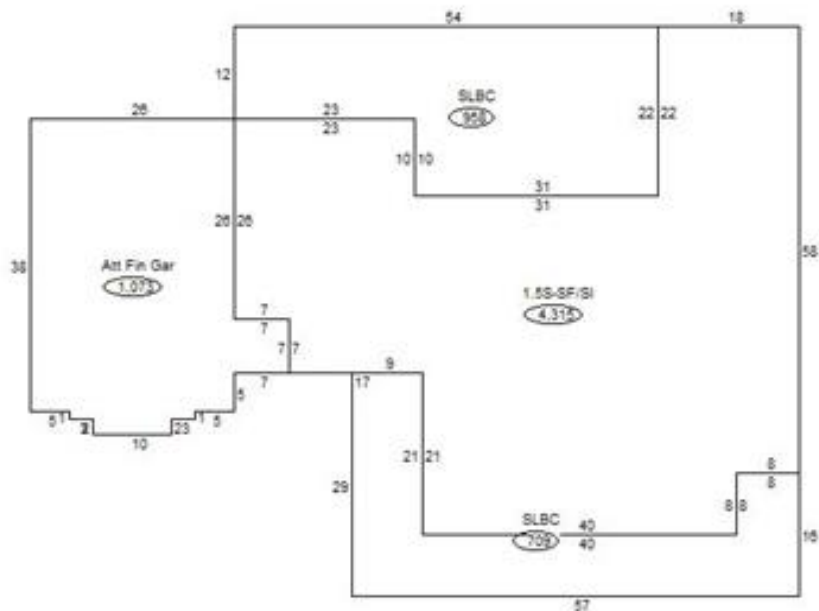

Sketch Vector Information

Sequence	Code	Type	Built Over	Scale	Section Label	Base Area	Multiplier	Total Area
1	R	5	Slab	20	1.5S-SF/SI	3,177	1.358	4,315
2	U	^UL		20	Upper Level (1)	1,138	1.000	1,138
3	G	5		20	Att Fin Gar	1,073	1.000	1,073
4	M	PRCH		20	SLBC	709	1.000	709
5	M	PRCH		20	SLBC	958	1.000	958
Total Building Area						3,177		4,315