



Rogers

Assessment Property Record Card for Tax Year 2026

Data provided by LISA DELOZIER County Assessor

Date 04/18/2026
Time 10:39:22
Page 1

Assessment Data					Primary Image																																												
Account 660106105 Parcel ID 000000-0001-019-0-000-00 Cadastral ID 08-21-15-05190 Property Type REAL - Real Property Property Class RRP VI Area 4 Tax Area 7 - OWASSO/LIMESTONE FIRE Name ID 342546 GALANOS, RICHARD J & MARY H 5315 E NORWOOD ST CLAREMORE OK 74019-0000 Parcel Location Situs 05315 E NORWOOD ST Subdivision BIRCHWOOD Lot/Block 0019 / 0001 Parcel Size 1 - Lots Sec/Twn/Rng 8 / 21 / 15 / 5 Neighborhood 1142 - R-V01-SW OWASSO School District S021 - OWASSO SCHOOLS																																																	
Legal Description Lot/Long: 36.31087784 -95.73478360																																																	
Building Permits					<table border="1"> <thead> <tr> <th>Number</th> <th>Description</th> <th>Opened</th> <th>Closed</th> <th>Amount</th> </tr> </thead> <tbody> <tr> <td>R22 107</td> <td>R23 NEW SFR 2339 SQ FT</td> <td>03/2022</td> <td>06/2023</td> <td>272,700</td> </tr> </tbody> </table>					Number	Description	Opened	Closed	Amount	R22 107	R23 NEW SFR 2339 SQ FT	03/2022	06/2023	272,700																														
Number	Description	Opened	Closed	Amount																																													
R22 107	R23 NEW SFR 2339 SQ FT	03/2022	06/2023	272,700																																													
Exemptions					Sale History																																												
<table border="1"> <thead> <tr> <th>Code</th> <th>Type</th> <th>Active</th> <th>Maximum</th> <th>Exemption</th> </tr> </thead> <tbody> <tr> <td>H</td> <td>Homestead</td> <td>Yes</td> <td>1,000</td> <td>1,000</td> </tr> </tbody> </table>					Code	Type	Active	Maximum	Exemption	H	Homestead	Yes	1,000	1,000	<table border="1"> <thead> <tr> <th>Bk/Pg</th> <th>Grantor</th> <th>Date</th> <th>Price</th> <th>Code</th> </tr> </thead> <tbody> <tr> <td>/</td> <td>LANDMARK HOMES LLC</td> <td>09/12/2023</td> <td>459,000</td> <td>YES</td> </tr> <tr> <td>/</td> <td>BIRCHWOOD DEVELOPMENT LLC</td> <td>08/10/2023</td> <td>0</td> <td>5</td> </tr> </tbody> </table>					Bk/Pg	Grantor	Date	Price	Code	/	LANDMARK HOMES LLC	09/12/2023	459,000	YES	/	BIRCHWOOD DEVELOPMENT LLC	08/10/2023	0	5															
Code	Type	Active	Maximum	Exemption																																													
H	Homestead	Yes	1,000	1,000																																													
Bk/Pg	Grantor	Date	Price	Code																																													
/	LANDMARK HOMES LLC	09/12/2023	459,000	YES																																													
/	BIRCHWOOD DEVELOPMENT LLC	08/10/2023	0	5																																													
Parcel Valuation																																																	
<table border="1"> <thead> <tr> <th>Source</th> <th>REAL</th> </tr> </thead> <tbody> <tr> <td>Remove Cap</td> <td>2024</td> </tr> </tbody> </table>		Source	REAL	Remove Cap	2024	<table border="1"> <thead> <tr> <th>Fair Cash</th> <th>Capped</th> <th>Asmnt Level</th> <th>Assessed</th> </tr> </thead> <tbody> <tr> <td>Land Value</td> <td>102,933</td> <td>101,536</td> <td>11%</td> <td>11,169</td> </tr> <tr> <td>Improvements</td> <td>395,201</td> <td>390,294</td> <td></td> <td>42,932</td> </tr> <tr> <td>Mobile Home</td> <td>0</td> <td>0</td> <td></td> <td>0</td> </tr> <tr> <td>Total Value</td> <td>498,134</td> <td>491,830</td> <td></td> <td>54,101</td> </tr> </tbody> </table>			Fair Cash	Capped	Asmnt Level	Assessed	Land Value	102,933	101,536	11%	11,169	Improvements	395,201	390,294		42,932	Mobile Home	0	0		0	Total Value	498,134	491,830		54,101	<table border="1"> <thead> <tr> <th>Levy Rate</th> <th>Current Tax</th> </tr> </thead> <tbody> <tr> <td>108.538</td> <td>5,872.01</td> </tr> <tr> <td>Assessed</td> <td>54,101</td> </tr> <tr> <td>Penalty</td> <td>0</td> </tr> <tr> <td>Exemption</td> <td>1,000</td> </tr> <tr> <td>Total Taxable</td> <td>53,101</td> </tr> </tbody> </table>		Levy Rate	Current Tax	108.538	5,872.01	Assessed	54,101	Penalty	0	Exemption	1,000	Total Taxable	53,101			
Source	REAL																																																
Remove Cap	2024																																																
Fair Cash	Capped	Asmnt Level	Assessed																																														
Land Value	102,933	101,536	11%	11,169																																													
Improvements	395,201	390,294		42,932																																													
Mobile Home	0	0		0																																													
Total Value	498,134	491,830		54,101																																													
Levy Rate	Current Tax																																																
108.538	5,872.01																																																
Assessed	54,101																																																
Penalty	0																																																
Exemption	1,000																																																
Total Taxable	53,101																																																
Assessment History																																																	
<table border="1"> <thead> <tr> <th>Tax Year</th> <th>Statement Number</th> <th>Billed Owner</th> <th>Tax Area</th> <th>Total Value</th> <th>Exemptions</th> <th>Taxable Value</th> <th>Billed Tax</th> </tr> </thead> <tbody> <tr> <td>2025</td> <td>2025-660106105</td> <td>GALANOS, RICHARD J &</td> <td>7</td> <td>481,859</td> <td>1000</td> <td>51,526</td> <td>5,603.00</td> </tr> <tr> <td>2024</td> <td>2024-660106105</td> <td>GALANOS, RICHARD J &</td> <td>7</td> <td>463,598</td> <td>1000</td> <td>49,996</td> <td>5,531.00</td> </tr> <tr> <td>2023</td> <td>2023-660106105</td> <td>GALANOS, RICHARD J &</td> <td>7</td> <td>9,678</td> <td>0</td> <td>1,065</td> <td>115.00</td> </tr> <tr> <td>2022</td> <td>2022-660106105</td> <td>BIRCHWOOD DEVELOPMENT LLC</td> <td>7</td> <td>9,678</td> <td>0</td> <td>1,065</td> <td>119.00</td> </tr> </tbody> </table>										Tax Year	Statement Number	Billed Owner	Tax Area	Total Value	Exemptions	Taxable Value	Billed Tax	2025	2025-660106105	GALANOS, RICHARD J &	7	481,859	1000	51,526	5,603.00	2024	2024-660106105	GALANOS, RICHARD J &	7	463,598	1000	49,996	5,531.00	2023	2023-660106105	GALANOS, RICHARD J &	7	9,678	0	1,065	115.00	2022	2022-660106105	BIRCHWOOD DEVELOPMENT LLC	7	9,678	0	1,065	119.00
Tax Year	Statement Number	Billed Owner	Tax Area	Total Value	Exemptions	Taxable Value	Billed Tax																																										
2025	2025-660106105	GALANOS, RICHARD J &	7	481,859	1000	51,526	5,603.00																																										
2024	2024-660106105	GALANOS, RICHARD J &	7	463,598	1000	49,996	5,531.00																																										
2023	2023-660106105	GALANOS, RICHARD J &	7	9,678	0	1,065	115.00																																										
2022	2022-660106105	BIRCHWOOD DEVELOPMENT LLC	7	9,678	0	1,065	119.00																																										



Rogers

Assessment Property Record Card for Tax Year 2026

Data provided by LISA DELOZIER County Assessor

Date 04/18/2026
Time 10:39:22
Page 2

Lot Data		Square-Foot - NBHD 1142 #1	
Lot Size	0	0	
Lot Count	1		
Units Buildable			
Non-Ag Acres	0.5251		
Topography			
Street Access			
Utilities			
Amenities		0	
		0	
Method	Square-Foot		
Base Lot Value	22,874.00 x 4.50 = 102,933		
Factor Value			
Adjustments	1.0000		
Lot Value	102,933		



\\tsclient\T\ROB STUFF\2023-6-8\IMG_0021.JPG 6/8/2023

Residential Data	
Type	1 Single Family Residence
Condition	4 - Good
Quality	4 - Good
Architecture	
Style	100% One Story
Exterior Wall	95% Veneer, Masonry 5% Veneer, Stone
Base/Total Area	2,346 / 2,346
Style	100% One Story
HVAC	100% Warmed & Cooled Air
Roof Cover	1 Composition Shingle
Area on Slab	2,346
Fixture/RghIn	/
Bed/F/H Bath	4 / 2.0 / 1.0
Basement Area	
Garage Type	1,039 Attached Garage - Finished
Remodel	
Year/Eff Age	2023 / 2

GRM Approach

GRM Code	
Gross Rent	0.00
Indicated Value	

Multiple Regression

MRA Code	
Adjusted R	
Indicated Value	

Direct Comparables

Selection Model	A Adam Test
Adjustment Model	1 2022 Residential
Comparables	6
Indicated Value	488,550 Per SqFt

Value Reconciliation

Selected Approach	Cost Approach		
Improvements	395,201		
Lot Value	102,933		
Indicated Value	498,134	212.33	Per SqFt
Agland Value			
Site Improvements			
Total Value	498,134	212.33	Total Value Per SqFt

Cost Approach Manual : 01/2025

Base Cost	114.22	Total Misc Impr	+	16,706
Roofing Adj	+ 5.87	Garage Cost	+	59,129
Subfloor Adj	+ -4.62	Total RCN	=	403,266
Heat/Cool Adj	+ 16.31	Depreciation (2%)	-	8,065
Plumbing Adj	+ 7.79	Lump Sums	+	0
Basement Adj	+ 0.00	RCNLD	=	395,201
Adj Base Cost	= 139.57	Lot Value	+	102,933
Total Area	x 2,346	Indicated Value	=	498,134
Adjusted Cost	= 327,431	Value Per SqFt		212.33

Miscellaneous Improvements

Code	Description	Sketch ID	Size	Year	Units	Unit Cost	Depr	Value
PRCH	Slab Porch - Covered	157304	9x6		54	33.02		1,783
PRCH	Slab Porch - Covered	157305	239		239	32.13		7,679
FPR1	Fireplace - Residential 1 Story			2023	1	7,243.87		7,244



Sketch Image

660106105

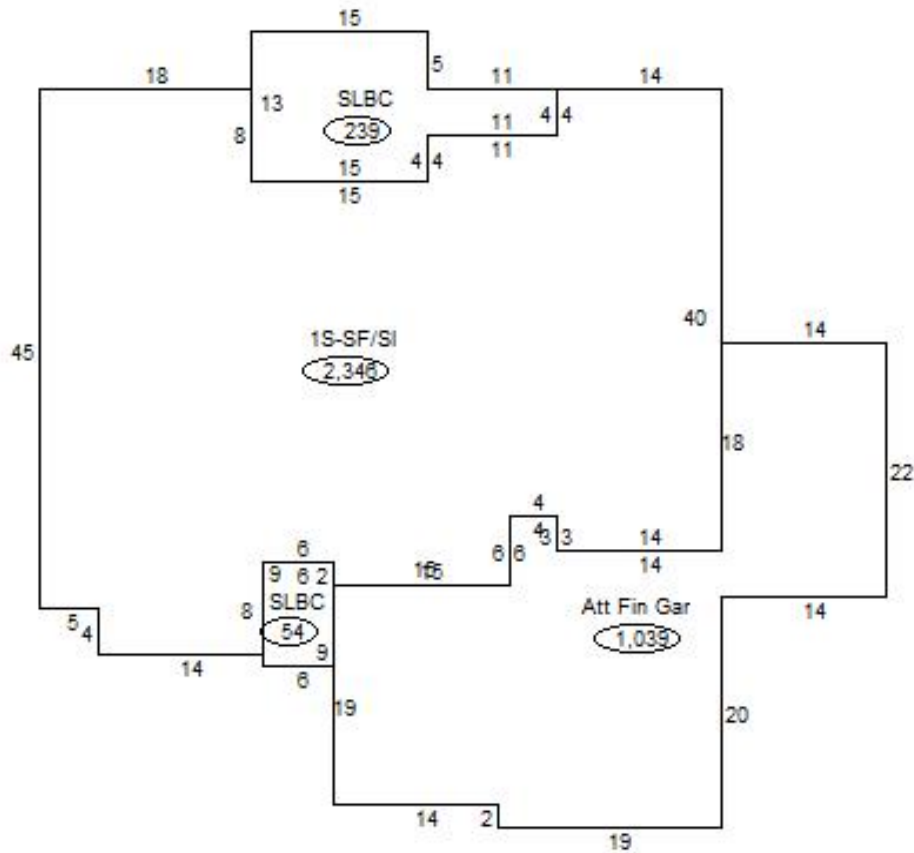

Sketch Vector Information

Sequence	Code	Type	Built Over	Scale	Section Label	Base Area	Multiplier	Total Area
1	R	1	Slab	20	1S-SF/SI	2,346	1.000	2,346
2	G	5		20	Att Fin Gar	1,039	1.000	1,039
3	M	PRCH		20	SLBC	54	1.000	54
4	M	PRCH		20	SLBC	239	1.000	239
Total Building Area						2,346		2,346