



Rogers

Assessment Property Record Card for Tax Year 2026

Data provided by LISA DELOZIER County Assessor

Date 04/18/2026
Time 10:40:34
Page 1

Assessment Data					Primary Image																																																	
Account 660106144 Parcel ID 000000-0002-026-0-000-00 Cadastral ID 08-21-15-05580 Property Type REAL - Real Property Property Class RRP VI Area 4 Tax Area 7 - OWASSO/LIMESTONE FIRE Name ID 340475 VENTERS, BRITTANY R & ERIC M 5042 E MADISON ST CLAREMORE OK 74019-0000 Parcel Location Situs 05042 E MADISON ST Subdivision BIRCHWOOD Lot/Block 0026 / 0002 Parcel Size 1 - Lots Sec/Twn/Rng 8 / 21 / 15 / 5 Neighborhood 1142 - R-V01-SW OWASSO School District S021 - OWASSO SCHOOLS																																																						
Legal Description Lot/Long: 36.30914375 -95.73869534																																																						
Legal Description LOT 26 BLOCK 2 BIRCHWOOD					Building Permits <table border="1"> <thead> <tr> <th>Number</th> <th>Description</th> <th>Opened</th> <th>Closed</th> <th>Amount</th> </tr> </thead> <tbody> <tr> <td>R21 000378</td> <td>R23- NEW 2545 SQ FT SFR</td> <td>11/2021</td> <td>02/2023</td> <td>250,000</td> </tr> </tbody> </table>					Number	Description	Opened	Closed	Amount	R21 000378	R23- NEW 2545 SQ FT SFR	11/2021	02/2023	250,000																																			
Number	Description	Opened	Closed	Amount																																																		
R21 000378	R23- NEW 2545 SQ FT SFR	11/2021	02/2023	250,000																																																		
Exemptions <table border="1"> <thead> <tr> <th>Code</th> <th>Type</th> <th>Active</th> <th>Maximum</th> <th>Exemption</th> </tr> </thead> <tbody> <tr> <td>H</td> <td>Homestead</td> <td>Yes</td> <td>1,000</td> <td>1,000</td> </tr> </tbody> </table>					Code	Type	Active	Maximum	Exemption	H	Homestead	Yes	1,000	1,000	Sale History <table border="1"> <thead> <tr> <th>Bk/Pg</th> <th>Grantor</th> <th>Date</th> <th>Price</th> <th>Code</th> </tr> </thead> <tbody> <tr> <td>/</td> <td>LANDMARK HOMES LLC</td> <td>12/22/2022</td> <td>499,000</td> <td>YES</td> </tr> <tr> <td>/</td> <td>BIRCHWOOD DEVELOPMENT LLC</td> <td>09/30/2022</td> <td>0</td> <td>WB</td> </tr> </tbody> </table>					Bk/Pg	Grantor	Date	Price	Code	/	LANDMARK HOMES LLC	12/22/2022	499,000	YES	/	BIRCHWOOD DEVELOPMENT LLC	09/30/2022	0	WB																				
Code	Type	Active	Maximum	Exemption																																																		
H	Homestead	Yes	1,000	1,000																																																		
Bk/Pg	Grantor	Date	Price	Code																																																		
/	LANDMARK HOMES LLC	12/22/2022	499,000	YES																																																		
/	BIRCHWOOD DEVELOPMENT LLC	09/30/2022	0	WB																																																		
Parcel Valuation <table border="1"> <thead> <tr> <th>Source</th> <th>REAL</th> <th>Fair Cash</th> <th>Capped</th> <th>Asmnt Level</th> <th>Assessed</th> <th>Levy Rate</th> <th>108.538</th> <th>Current Tax</th> </tr> </thead> <tbody> <tr> <td>Remove Cap</td> <td>2023</td> <td>Land Value</td> <td>104,840</td> <td>104,840</td> <td>11%</td> <td>11,532</td> <td>Assessed</td> <td>56,449 6,126.86</td> </tr> <tr> <td>Year Frozen</td> <td></td> <td>Improvements</td> <td>414,221</td> <td>408,336</td> <td></td> <td>44,917</td> <td>Penalty</td> <td>0</td> </tr> <tr> <td>Uncapped Value</td> <td>0</td> <td>Mobile Home</td> <td>0</td> <td>0</td> <td>0</td> <td>0</td> <td>Exemption</td> <td>1,000 -98.00</td> </tr> <tr> <td>TIF Project ID</td> <td>0</td> <td>Total Value</td> <td>519,061</td> <td>513,176</td> <td>56,449</td> <td>Total Taxable</td> <td>55,449</td> <td>6,029.00</td> </tr> </tbody> </table>										Source	REAL	Fair Cash	Capped	Asmnt Level	Assessed	Levy Rate	108.538	Current Tax	Remove Cap	2023	Land Value	104,840	104,840	11%	11,532	Assessed	56,449 6,126.86	Year Frozen		Improvements	414,221	408,336		44,917	Penalty	0	Uncapped Value	0	Mobile Home	0	0	0	0	Exemption	1,000 -98.00	TIF Project ID	0	Total Value	519,061	513,176	56,449	Total Taxable	55,449	6,029.00
Source	REAL	Fair Cash	Capped	Asmnt Level	Assessed	Levy Rate	108.538	Current Tax																																														
Remove Cap	2023	Land Value	104,840	104,840	11%	11,532	Assessed	56,449 6,126.86																																														
Year Frozen		Improvements	414,221	408,336		44,917	Penalty	0																																														
Uncapped Value	0	Mobile Home	0	0	0	0	Exemption	1,000 -98.00																																														
TIF Project ID	0	Total Value	519,061	513,176	56,449	Total Taxable	55,449	6,029.00																																														
Assessment History <table border="1"> <thead> <tr> <th>Tax Year</th> <th>Statement Number</th> <th>Billed Owner</th> <th>Tax Area</th> <th>Total Value</th> <th>Exemptions</th> <th>Taxable Value</th> <th>Billed Tax</th> </tr> </thead> <tbody> <tr> <td>2025</td> <td>2025-660106144</td> <td>VENTERS, BRITTANY R &</td> <td>7</td> <td>498,230</td> <td>1000</td> <td>53,805</td> <td>5,851.00</td> </tr> <tr> <td>2024</td> <td>2024-660106144</td> <td>VENTERS, BRITTANY R &</td> <td>7</td> <td>498,964</td> <td>1000</td> <td>53,886</td> <td>5,961.00</td> </tr> <tr> <td>2023</td> <td>2023-660106144</td> <td>VENTERS, BRITTANY R &</td> <td>7</td> <td>498,964</td> <td>1000</td> <td>53,886</td> <td>5,834.00</td> </tr> <tr> <td>2022</td> <td>2022-660106144</td> <td>BIRCHWOOD DEVELOPMENT LLC</td> <td>7</td> <td>9,678</td> <td>0</td> <td>1,065</td> <td>119.00</td> </tr> </tbody> </table>										Tax Year	Statement Number	Billed Owner	Tax Area	Total Value	Exemptions	Taxable Value	Billed Tax	2025	2025-660106144	VENTERS, BRITTANY R &	7	498,230	1000	53,805	5,851.00	2024	2024-660106144	VENTERS, BRITTANY R &	7	498,964	1000	53,886	5,961.00	2023	2023-660106144	VENTERS, BRITTANY R &	7	498,964	1000	53,886	5,834.00	2022	2022-660106144	BIRCHWOOD DEVELOPMENT LLC	7	9,678	0	1,065	119.00					
Tax Year	Statement Number	Billed Owner	Tax Area	Total Value	Exemptions	Taxable Value	Billed Tax																																															
2025	2025-660106144	VENTERS, BRITTANY R &	7	498,230	1000	53,805	5,851.00																																															
2024	2024-660106144	VENTERS, BRITTANY R &	7	498,964	1000	53,886	5,961.00																																															
2023	2023-660106144	VENTERS, BRITTANY R &	7	498,964	1000	53,886	5,834.00																																															
2022	2022-660106144	BIRCHWOOD DEVELOPMENT LLC	7	9,678	0	1,065	119.00																																															



Rogers

Assessment Property Record Card for Tax Year 2026

Data provided by LISA DELOZIER County Assessor

Date 04/18/2026
 Time 10:40:34
 Page 2

Lot Data		Square-Foot - NBHD 1142 #1	
Lot Size	0	0	
Lot Count	1		
Units Buildable			
Non-Ag Acres	0.5428		
Topography			
Street Access			
Utilities			
Amenities			0
			0
Method	Square-Foot		
Base Lot Value	23,644.00 x 4.43 = 104,840		
Factor Value			
Adjustments	1.0000		
Lot Value	104,840		



\\tsclient\T\ROB STUFF\2023-2-24\IMG_0002.JPG 2/24/2023

Residential Data	
Type	1 Single Family Residence
Condition	4 - Good
Quality	4 - Good
Architecture	
Style	100% One Story
Exterior Wall	95% Veneer, Masonry 5% Veneer, Stone
Base/Total Area	2,572 / 2,572
Style	100% One Story
HVAC	100% Warmed & Cooled Air
Roof Cover	1 Composition Shingle
Area on Slab	2,572
Fixture/RghIn	/
Bed/F/H Bath	4 / 2.0 / 1.0
Basement Area	
Garage Type	766 Attached Garage - Finished
Remodel	
Year/Eff Age	2023 / 2

GRM Approach

GRM Code	
Gross Rent	0.00
Indicated Value	

Multiple Regression

MRA Code	
Adjusted R	
Indicated Value	

Direct Comparables

Selection Model	A Adam Test
Adjustment Model	1 2022 Residential
Comparables	6
Indicated Value	491,320 Per SqFt

Value Reconciliation

Selected Approach	Cost Approach		
Improvements	414,221		
Lot Value	104,840		
Indicated Value	519,061	201.81	Per SqFt
Agland Value			
Site Improvements			
Total Value	519,061	201.81	Total Value Per SqFt

Cost Approach Manual : 01/2025

Base Cost	112.97	Total Misc Impr	+	25,175
Roofing Adj	+ 5.79	Garage Cost	+	43,593
Subfloor Adj	+ -4.58	Total RCN	=	422,675
Heat/Cool Adj	+ 16.31	Depreciation (2%)	-	8,454
Plumbing Adj	+ 7.11	Lump Sums	+	0
Basement Adj	+ 0.00	RCNLD	=	414,221
Adj Base Cost	= 137.60	Lot Value	+	104,840
Total Area	x 2,572	Indicated Value	=	519,061
Adjusted Cost	= 353,907	Value Per SqFt		201.81

Miscellaneous Improvements

Code	Description	Sketch ID	Size	Year	Units	Unit Cost	Depr	Value
PRCH	Slab Porch - Covered	156400	9x6		54	33.02		1,783
PRCH	Slab Porch - Covered	156401	535		535	31.20		16,692
FPPF	Fireplace - Prefabricated			2023	1	6,700.26		6,700



Rogers

Assessment Property Record Card for Tax Year 2026

Data provided by LISA DELOZIER County Assessor

Date 04/18/2026
 Time 10:40:34
 Page 3

Sketch Image

660106144

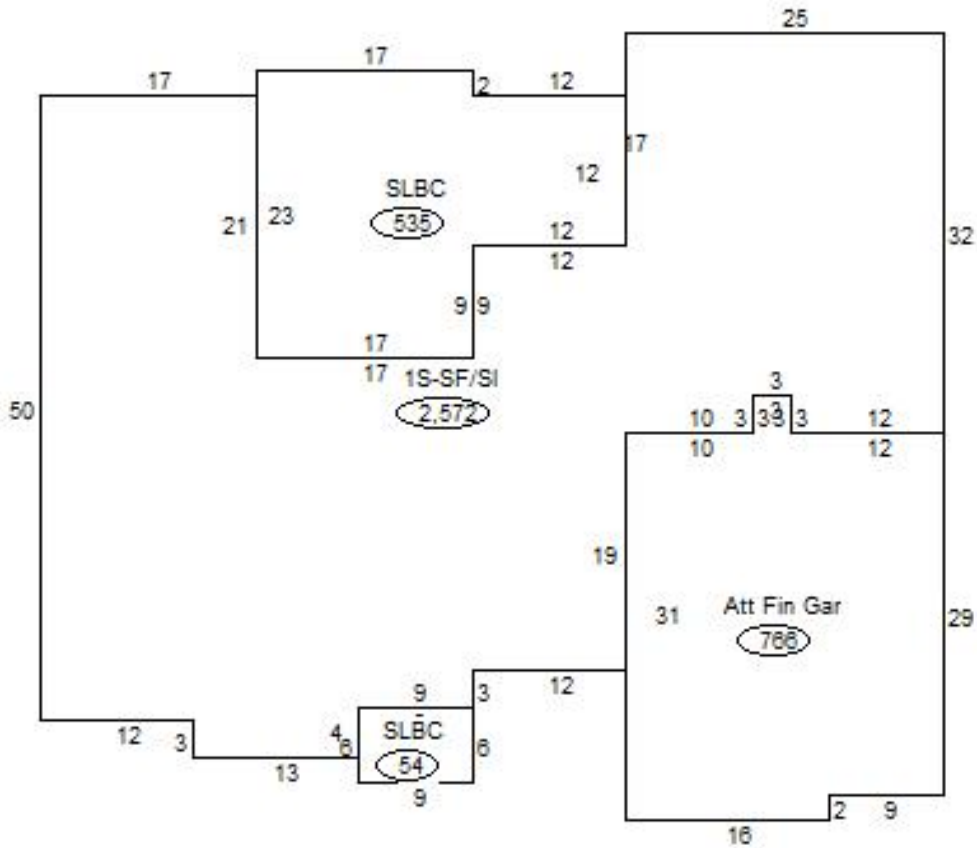

Sketch Vector Information

Sequence	Code	Type	Built Over	Scale	Section Label	Base Area	Multiplier	Total Area
1	R	1	Slab	20	1S-SF/SI	2,572	1.000	2,572
2	G	5		20	Att Fin Gar	766	1.000	766
3	M	PRCH		20	SLBC	54	1.000	54
4	M	PRCH		20	SLBC	535	1.000	535
Total Building Area						2,572		2,572