



# Rogers

## Assessment Property Record Card for Tax Year 2026

Data provided by LISA DELOZIER County Assessor

Date 04/18/2026  
Time 10:43:34  
Page 1

Assessment Data					Primary Image				
Account	660106250								
Parcel ID	000000-0001-002-0-000-00								
Cadastral ID	06-20-15-02720								
Property Type	REAL - Real Property								
Property Class	RRP	VI Area	3						
Tax Area	20 - CATOOSA RURAL								
Name ID	345564								
SOKOLOSKY, ALEXANDER									
5989 N MEADOWS RIDGE RD OWASSO OK 74055-0000									
Parcel Location									
Situs	05989 N MEADOWS RIDGE RD								
Subdivision	DEER RUN AT STONE CANYON PHASE IV								
Lot/Block	0002 / 0001	Parcel Size	1 - Lots						
Sec/Twn/Rng	6 / 20 / 15 / 5								
Neighborhood	1039 - R-V04, SW OWASSO								
School District	S002 - CATOOSA SCHOOLS								
Legal Description Lat/Long: 36.24060583 -95.76117378									
Building Permits									
LOT 2 BLOCK 1 DEER RUN AT STONE CANYON PHASE IV									
Number	Description	Opened	Closed	Amount					
R23 325	R24 NEW SFR 3410 SQ FT	10/2023	08/2024	625,000					
Exemptions									
Code	Type	Active	Maximum	Exemption					
H	Homestead	Yes	1,000	1,000					
Sale History									
Bk/Pg	Grantor	Date	Price	Code					
/	EPIC CUSTOM HOMES LLC	10/10/2024	796,500	YES					
/	C.A.B.O DEVELOPMENT COMPANY LL	06/09/2022	932,500	WB					
Parcel Valuation									
Source	REAL	Fair Cash	Capped	Asmnt Level	Assessed	Levy Rate	92.860	Current Tax	
Remove Cap	2025	Land Value	192,943	192,943	11%	21,224	Assessed	90,244 8,380.06	
Year Frozen		Improvements	629,470	627,452		69,020	Penalty	0	
Uncapped Value	0	Mobile Home	0	0	0	0	Exemption	1,000 -93.00	
TIF Project ID	0	Total Value	822,413	820,395	90,244	Total Taxable	89,244	8,287.00	
Assessment History									
Tax Year	Statement Number	Billed Owner	Tax Area	Total Value	Exemptions	Taxable Value	Billed Tax		
2025	2025-660106250	SOKOLOSKY, ALEXANDER	20	796,500	1000	86,615	8,043.00		
2024	2024-660106250	EPIC CUSTOM HOMES LLC	20	93,252	0	516	47.00		
2023	2023-660106250	EPIC CUSTOM HOMES LLC	20	4,470	0	492	43.00		
2022	2022-660106250	EPIC CUSTOM HOMES LLC	20	4,470	0	492	43.00		



# Rogers

## Assessment Property Record Card for Tax Year 2026

Data provided by LISA DELOZIER County Assessor

Date 04/18/2026  
Time 10:43:34  
Page 2

Lot Data	Square-Foot - NBHD 1039 #1	Primary Image
Lot Size	0 0	
Lot Count	1	
Units Buildable		
Non-Ag Acres	0.6677	
Topography		
Street Access		
Utilities		
Amenities	0	
	0	
Method	Square-Foot	
Base Lot Value	29,083.00 x 4.64 = 134,891	
Factor Value		
Adjustments	1.4304	
Lot Value	192,943	

Residential Data	
Type	1 Single Family Residence
Condition	4 - Good
Quality	6 - Excellent
Architecture	TRAD TRADITIONAL
Style	100% One Story
Exterior Wall	100% Veneer, Masonry
Base/Total Area	3,239 / 3,239
Style	100% One Story
HVAC	100% Warmed & Cooled Air
Roof Cover	1 Composition Shingle
Area on Slab	3,239
Fixture/RghIn	/
Bed/F/H Bath	4 / 3.0 / 1.0
Basement Area	
Garage Type	828 Attached Garage - Finished 3 Stalls
Remodel	
Year/Eff Age	2024 / 1



660106250\_001.JPG 10/7/2025

GRM Approach	
GRM Code	
Gross Rent	0.00
Indicated Value	

Multiple Regression	
MRA Code	
Adjusted R	
Indicated Value	

Direct Comparables	
Selection Model	A Adam Test
Adjustment Model	1 2022 Residential
Comparables	
Indicated Value	

Cost Approach				Manual : 01/2025			
Base Cost	127.91	Total Misc Impr	+	39,957			
Roofing Adj	+ 7.46	Garage Cost	+	83,785			
Subfloor Adj	+ -8.68	Total RCN	=	635,828			
Heat/Cool Adj	+ 21.74	Depreciation ( 1%)	-	6,358			
Plumbing Adj	+ 9.67	Lump Sums	+	0			
Basement Adj	+ 0.00	RCNLD	=	629,470			
Adj Base Cost	= 158.10	Lot Value	+	192,943			
Total Area	x 3,239	Indicated Value	=	822,413			
Adjusted Cost	= 512,086	Value Per SqFt		253.91			

Value Reconciliation			
Selected Approach	Cost Approach		
Improvements	629,470		
Lot Value	192,943		
Indicated Value	822,413	253.91	Per SqFt
Agland Value			
Site Improvements			
Total Value	822,413	253.91	Total Value Per SqFt

Miscellaneous Improvements								
Code	Description	Sketch ID	Size	Year	Units	Unit Cost	Depr	Value
PRCH	Porch	160698	177		177	46.07		8,154
PRCH	Porch	160699	500		500	44.29		22,145
FPR1	Fireplace - Residential 1 Story		1	2024	1	9,658.49		9,658
SHLT	STORM SHELTER		1	2024	1	0.00		



# Rogers

## Assessment Property Record Card for Tax Year 2026

Data provided by LISA DELOZIER County Assessor

Date 04/18/2026  
 Time 10:43:34  
 Page 3

Sketch Image

660106250

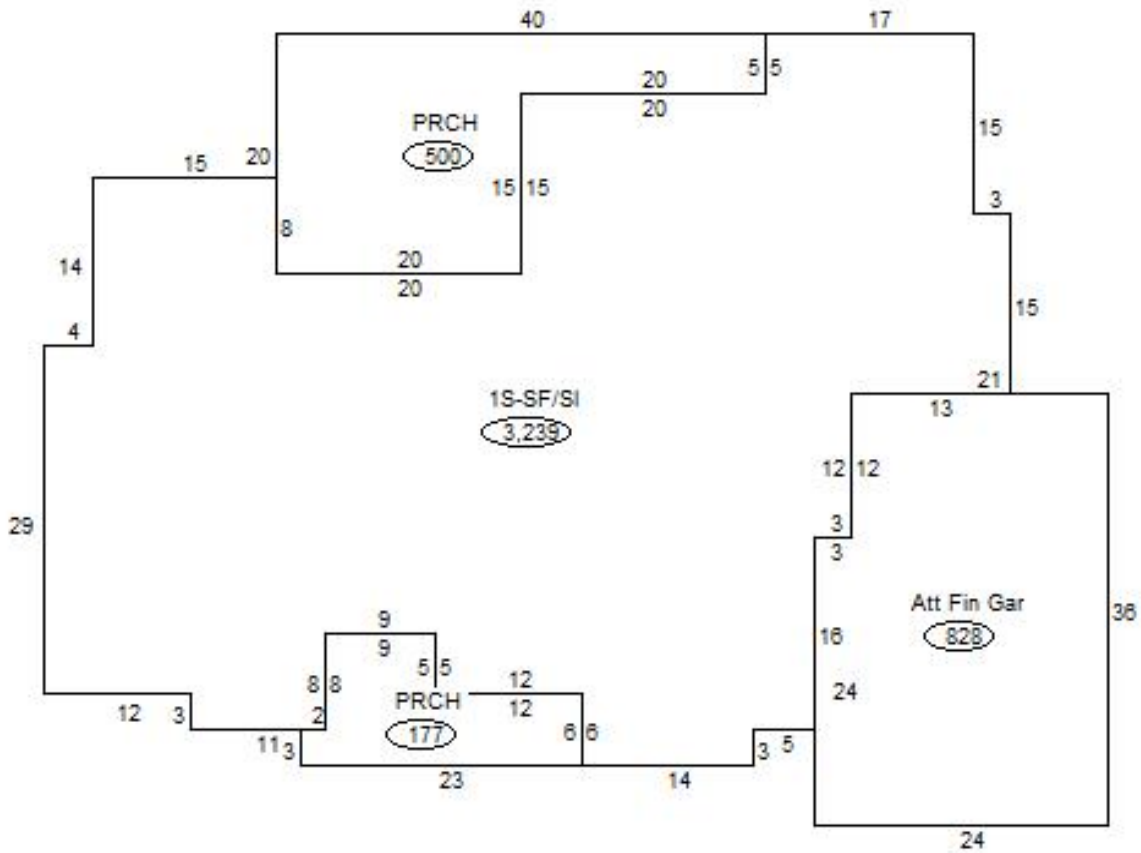

### Sketch Vector Information

Sequence	Code	Type	Built Over	Scale	Section Label	Base Area	Multiplier	Total Area
1	R	1	Slab	20	1S-SF/Sl	3,239	1.000	3,239
2	G	5		20	Att Fin Gar	828	1.000	828
3	M	PRCH		20	PRCH	177	1.000	177
4	M	PRCH		20	PRCH	500	1.000	500
<b>Total Building Area</b>						3,239		3,239