



Rogers

Assessment Property Record Card for Tax Year 2026

Data provided by LISA DELOZIER County Assessor

Date 04/18/2026
Time 10:43:44
Page 1

Assessment Data					Primary Image				
Account	660106256				<p>660106256_001.JPG 8/20/2025</p>				
Parcel ID	000000-0001-008-0-000-00								
Cadastral ID	06-20-15-02780								
Property Type	REAL - Real Property								
Property Class	RRP	VI Area	3						
Tax Area	20 - CATOOSA RURAL								
Name ID	344950								
MURDOCH, KIRK & JYNA									
5831 N MEADOWS RIDGE RD OWASSO OK 74055-0000									
Parcel Location									
Situs	05831 N MEADOWS RIDGE RD								
Subdivision	DEER RUN AT STONE CANYON PHASE IV								
Lot/Block	0008 / 0001	Parcel Size	1 - Lots						
Sec/Twn/Rng	6 / 20 / 15 / 5								
Neighborhood	1039 - R-V04, SW OWASSO								
School District	S002 - CATOOSA SCHOOLS								
Legal Description Lat/Long: 36.23826022 -95.76127956									
LOT 8 BLOCK 1 DEER RUN AT STONE CANYON PHASE IV									
Building Permits									
Number		Description	Opened	Closed	Amount				
R24 313	NEW SFR	3923 SQ FT	09/2024	08/2025	850,000				
Exemptions									
Code	Type	Active	Maximum	Exemption					
H	Homestead	Yes	1,000	1,000					
Sale History									
Bk/Pg	Grantor	Date	Price	Code					
/	EPIC CUSTOM HOMES LLC	08/06/2024	0	4					
/	C.A.B.O DEVELOPMENT COMPANY LL	06/09/2022	932,500	WB					
Parcel Valuation									
Source	REAL	Fair Cash	Capped	Asmnt Level	Assessed	Levy Rate	92.860	Current Tax	
Remove Cap	2023	Land Value	109,143	5,075	11%	558	Assessed	80,377 7,463.81	
Year Frozen		Improvements	725,625	725,624		79,819	Penalty	0	
Uncapped Value	725,625	Mobile Home	0	0		0	Exemption	1,000 -93.00	
TIF Project ID	0	Total Value	834,768	730,699		80,377	Total Taxable	79,377 7,371.00	
Assessment History									
Tax Year	Statement Number	Billed Owner	Tax Area	Total Value	Exemptions	Taxable Value	Billed Tax		
2025	2025-660106256	MURDOCH, KIRK & JYNA	20	109,143	0	542	50.00		
2024	2024-660106256	MURDOCH, KIRK & JYNA	20	93,250	0	516	47.00		
2023	2023-660106256	EPIC CUSTOM HOMES LLC	20	4,470	0	492	43.00		
2022	2022-660106256	EPIC CUSTOM HOMES LLC	20	4,470	0	492	43.00		



Rogers

Assessment Property Record Card for Tax Year 2026

Data provided by LISA DELOZIER County Assessor

Date 04/18/2026
Time 10:43:44
Page 2

Lot Data	Square-Foot - NBHD 1039 #1	Primary Image
Lot Size	0 0	
Lot Count	1	
Units Buildable		
Non-Ag Acres	0.3763	
Topography		
Street Access		
Utilities		
Amenities	0	
	0	
Method	Square-Foot	
Base Lot Value	16,393.00 x 5.70 = 93,440	
Factor Value		
Adjustments	1.1681	
Lot Value	109,143	

Residential Data	
Type	1 Single Family Residence
Condition	3 - Average
Quality	4.5 - Good
Architecture	TRAD TRADITIONAL
Style	100% One Story
Exterior Wall	75% Veneer, Masonry 25% Frame, Stucco
Base/Total Area	3,820 / 3,820
Style	100% One Story
HVAC	100% Warmed & Cooled Air
Roof Cover	1 Composition Shingle
Area on Slab	3,820
Fixture/RghIn	/
Bed/F/H Bath	3 / 3.0 / 1.0
Basement Area	
Garage Type	2,288 Attached Garage - Finished 4 Stalls
Remodel	
Year/Eff Age	2025 / 1

GRM Approach	
GRM Code	
Gross Rent	0.00
Indicated Value	

Multiple Regression	
MRA Code	
Adjusted R	
Indicated Value	

Direct Comparables	
Selection Model	A Adam Test
Adjustment Model	1 2022 Residential
Comparables	
Indicated Value	

Cost Approach				Manual : 01/2025			
Base Cost	110.32	Total Misc Impr	+ 75,386				
Roofing Adj	+ 5.83	Garage Cost	+ 138,813				
Subfloor Adj	+ -4.28	Total RCN	= 732,955				
Heat/Cool Adj	+ 17.38	Depreciation (1%)	- 7,330				
Plumbing Adj	+ 6.55	Lump Sums	+ 0				
Basement Adj	+ 0.00	RCNLD	= 725,625				
Adj Base Cost	= 135.80	Lot Value	+ 109,143				
Total Area	x 3,820	Indicated Value	= 834,768				
Adjusted Cost	= 518,756	Value Per SqFt	218.53				

Value Reconciliation	
Selected Approach	Cost Approach
Improvements	725,625
Lot Value	109,143
Indicated Value	834,768
Agland Value	218.53 Per SqFt
Site Improvements	
Total Value	834,768 218.53 Total Value Per SqFt

Miscellaneous Improvements								
Code	Description	Sketch ID	Size	Year	Units	Unit Cost	Depr	Value
PRCH	Porch	173126	90		90	36.34		3,271
PATO	Patio - Open	173127	195		195	14.05		2,740
EPKG	Enclosed Porch - Kneewall Glass	173129	699		699	43.24		30,225
PATC	Patio - Covered	173130	15x5		75	26.64		1,998
PATC	Patio - Covered	173131	15x5		75	26.64		1,998
FPPF	Fireplace - Prefabricated		1	2025	1	7,141.75		7,142
ODFP	Outdoor Fireplace/Firepit		1	2025	1	4,987.18		4,987
ODRK	Outdoor Kitchen		1	2025	1	6,010.00		6,010
SOLP	Solar Panels		39	2025	39	436.28		17,015



Rogers

Assessment Property Record Card for Tax Year 2026

Data provided by LISA DELOZIER County Assessor

Date 04/18/2026
 Time 10:43:44
 Page 3

Sketch Image

660106256

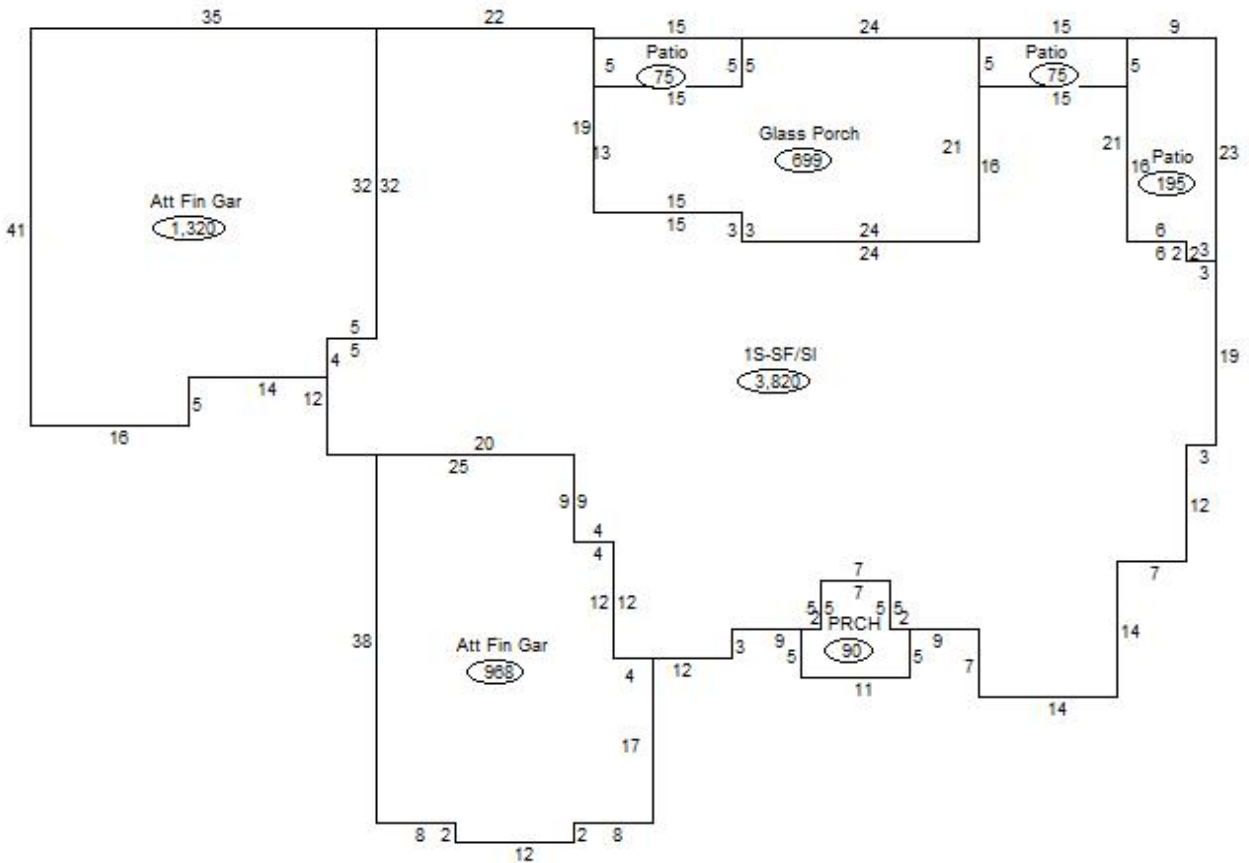

Sketch Vector Information

Sequence	Code	Type	Built Over	Scale	Section Label	Base Area	Multiplier	Total Area
1	G	5		20	Att Fin Gar	1,320	1.000	1,320
2	G	5		20	Att Fin Gar	968	1.000	968
3	M	PRCH		20	PRCH	90	1.000	90
4	M	PATO		20	Patio	195	1.000	195
5	R	1	Slab	20	1S-SF/Sl	3,820	1.000	3,820
6	M	EPKG		20	Glass Porch	699	1.000	699
7	M	PATC		20	Patio	75	1.000	75
8	M	PATC		20	Patio	75	1.000	75
Total Building Area						3,820		3,820