



Rogers

Assessment Property Record Card for Tax Year 2026

Data provided by LISA DELOZIER County Assessor

Date 04/18/2026
 Time 10:43:48
 Page 1

Assessment Data				Primary Image						
Account	660106258									
Parcel ID	000000-0002-001-0-000-00									
Cadastral ID	01-20-14-04710									
Property Type	REAL - Real Property									
Property Class	RRP	VI Area	3							
Tax Area	3 - OWASSO RURAL/NO FIRE									
Name ID	341058									
MALPIEDE, DANIEL SCOTT & PATRICIA LYNN WEBER-MALPIEDE										
6018 N MEADOWS RIDGE RD OWASSO OK 74055-0000										
Parcel Location										
Situs	06018 N MEADOWS RIDGE RD									
Subdivision	DEER RUN AT STONE CANYON PHASE IV									
Lot/Block	0001 / 0002	Parcel Size	1 - Lots							
Sec/Twn/Rng	1 / 20 / 14 / 5									
Neighborhood	1039 - R-V04, SW OWASSO									
School District	S021 - OWASSO SCHOOLS									
Legal Description Lat/Long: 36.24098038 -95.76197952				Building Permits						
LOT 1 BLOCK 2 DEER RUN AT STONE CANYON PHASE IV				Number	Description	Opened	Closed	Amount		
				R22 337	R23 NEW SFR 3519 SQ FT	08/2022	03/2023	235,000		
Exemptions				Sale History						
Code	Type	Active	Maximum	Exemption	Bk/Pg	Grantor	Date	Price	Code	
					/	EXECUTIVE HOMES LLC	03/17/2023	655,500	YES	
					/	C.A.B.O DEVELOPMENT COMPANY LL	03/15/2022	812,500	WB	
Parcel Valuation										
Source	REAL		Fair Cash	Capped	Asmnt Level	Assessed	Levy Rate	97.960	Current Tax	
Remove Cap	2024		Land Value	147,923	147,923	11%	Assessed	74,872	7,334.46	
Year Frozen			Improvements	535,119	532,729		Penalty	0		
Uncapped Value	0		Mobile Home	0	0	0	Exemption	0	0.00	
TIF Project ID	0		Total Value	683,042	680,652	74,872	Total Taxable	74,872	7,334.00	
Assessment History										
Tax Year	Statement Number	Billed Owner			Tax Area	Total Value	Exemptions	Taxable Value	Billed Tax	
2025	2025-660106258	MALPIEDE, DANIEL SCOTT &			3	648,240	0	71,307	6,985.00	
2024	2024-660106258	MALPIEDE, DANIEL SCOTT &			3	678,306	0	74,614	7,168.00	
2023	2023-660106258	MALPIEDE, DANIEL SCOTT &			3	4,470	0	492	46.00	
2022	2022-660106258	EXECUTIVE HOMES LLC			3	4,470	0	492	48.00	



Rogers

Assessment Property Record Card for Tax Year 2026

Data provided by LISA DELOZIER County Assessor

Date 04/18/2026
Time 10:43:48
Page 2

Lot Data		Square-Foot - NBHD 1039 #1	
Lot Size	0	0	
Lot Count	1		
Units Buildable			
Non-Ag Acres	0.5516		
Topography			
Street Access			
Utilities			
Amenities			0
			0
Method	Square-Foot		
Base Lot Value	24,030.00 x 5.13 = 123,269		
Factor Value			
Adjustments	1.2000		
Lot Value	147,923		



\\tsclient\T\ROB STUFF\2023-3-20\IMG_0015.JPG 3/20/2023

Residential Data	
Type	1 Single Family Residence
Condition	5 - Very Good
Quality	4.5 - Good
Architecture	TRAD TRADITIONAL
Style	100% 1 1/2 Story Finished
Exterior Wall	95% Veneer, Masonry 5% Veneer, Stone
Base/Total Area	2,456 / 3,527
Style	100% 1 1/2 Story Finished
HVAC	100% Warmed & Cooled Air
Roof Cover	1 Composition Shingle
Area on Slab	2,456
Fixture/RghIn	/
Bed/F/H Bath	4 / 3.0 / 1.0
Basement Area	
Garage Type	896 Attached Garage - Finished
Remodel	
Year/Eff Age	2023 / 1

GRM Approach

GRM Code	
Gross Rent	0.00
Indicated Value	

Multiple Regression

MRA Code	
Adusted R	
Indicated Value	

Direct Comparables

Selection Model	A Adam Test
Adjustment Model	1 2022 Residential
Comparables	
Indicated Value	

Value Reconciliation

Selected Approach	Cost Approach		
Improvements	535,119		
Lot Value	147,923		
Indicated Value	683,042	193.66	Per SqFt
Agland Value			
Site Improvements			
Total Value	683,042	193.66	Total Value Per SqFt

Cost Approach		Manual : 01/2025	
Base Cost	105.46	Total Misc Impr	+ 23,880
Roofing Adj	+ 4.33	Garage Cost	+ 54,360
Subfloor Adj	+ -3.20	Total RCN	= 540,524
Heat/Cool Adj	+ 17.38	Depreciation (1%)	- 5,405
Plumbing Adj	+ 7.10	Lump Sums	+ 0
Basement Adj	+ 0.00	RCNLD	= 535,119
Adj Base Cost	= 131.07	Lot Value	+ 147,923
Total Area	x 3,527	Indicated Value	= 683,042
Adjusted Cost	= 462,284	Value Per SqFt	193.66

Miscellaneous Improvements

Code	Description	Sketch ID	Size	Year	Units	Unit Cost	Depr	Value
PRCH	Slab Porch - Covered	156588	11x5		55	36.48		2,006
PRCH	Slab Porch - Covered	156589	298		298	35.20		10,490
FPPF	Fireplace - Prefabricated			1 2023	1	7,141.75		7,142
GENR	Generator - Residential Standby			1 2023	1	4,242.00		4,242



Rogers

Assessment Property Record Card for Tax Year 2026

Data provided by LISA DELOZIER County Assessor

Date 04/18/2026
 Time 10:43:48
 Page 3

Sketch Image

660106258

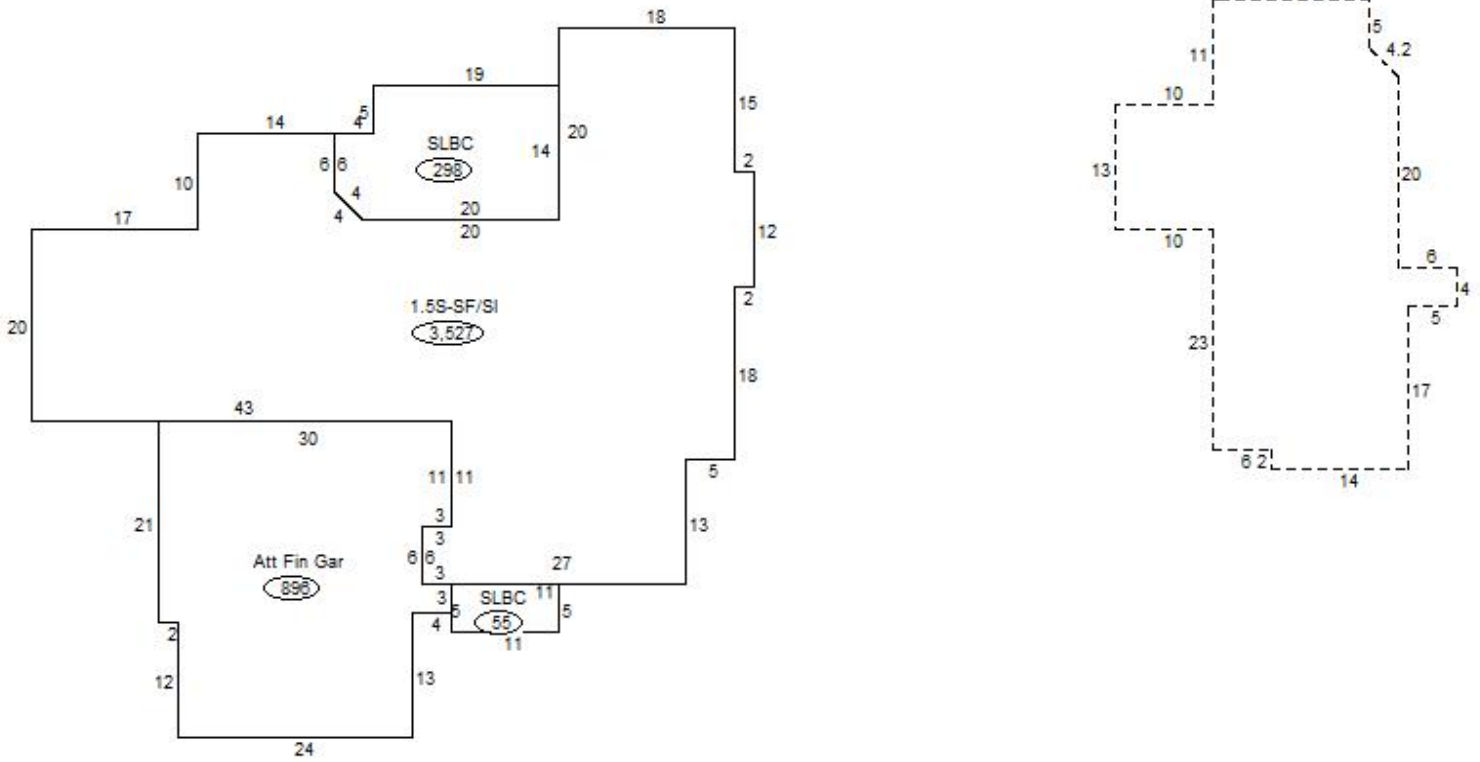

Sketch Vector Information

Sequence	Code	Type	Built Over	Scale	Section Label	Base Area	Multiplier	Total Area
1	R	5	Slab	20	1.5S-SF/SI	2,456	1.436	3,527
2	U	^UL		20	Upper Level (1)	1,071	1.000	1,071
3	G	5		20	Att Fin Gar	896	1.000	896
4	M	PRCH		20	SLBC	55	1.000	55
5	M	PRCH		20	SLBC	298	1.000	298
Total Building Area						2,456		3,527