



Rogers

Assessment Property Record Card for Tax Year 2026

Data provided by LISA DELOZIER County Assessor

Date 04/18/2026
Time 10:45:14
Page 1

Assessment Data					Primary Image														
Account 660106303 Parcel ID 000000-0004-019-0-000-00 Cadastral ID 01-20-14-05160 Property Type REAL - Real Property Property Class RRP VI Area 3 Tax Area 3 - OWASSO RURAL/NO FIRE Name ID 340892 TRACY, BRADLEY & TONYA 5856 N RIVER BIRCH RD OWASSO OK 74055-0000 Parcel Location Situs 05856 N RIVER BIRCH RD Subdivision DEER RUN AT STONE CANYON PHASE IV Lot/Block 0019 / 0004 Parcel Size 1 - Lots Sec/Twn/Rng 1 / 20 / 14 / 5 Neighborhood 1039 - R-V04, SW OWASSO School District S021 - OWASSO SCHOOLS					<p>\\tsclient\T\ROB STUFF\2023-6-28\IMG_0013.JPG 6/28/2023</p>														
Legal Description Lat/Long: 36.23875169 -95.76342324																			
LOT 19 BLOCK 4 DEER RUN AT STONE CANYON PHASE IV					Building Permits <table border="1"> <thead> <tr> <th>Number</th> <th>Description</th> <th>Opened</th> <th>Closed</th> <th>Amount</th> </tr> </thead> <tbody> <tr> <td>R22 144</td> <td>R23 NEW SFR 2557 SQ FT</td> <td>04/2022</td> <td>06/2023</td> <td>325,000</td> </tr> </tbody> </table>					Number	Description	Opened	Closed	Amount	R22 144	R23 NEW SFR 2557 SQ FT	04/2022	06/2023	325,000
Number	Description	Opened	Closed	Amount															
R22 144	R23 NEW SFR 2557 SQ FT	04/2022	06/2023	325,000															
Exemptions					Sale History														
Code	Type	Active	Maximum	Exemption	Bk/Pg	Grantor	Date	Price	Code										
					/	ASHER HOMES LLC	02/22/2023	518,000	YES										
					/	C.A.B.O DEVELOPMENT COMPANY LL	04/15/2022	90,000	15										
Parcel Valuation																			
Source	REAL		Fair Cash	Capped	Asmnt Level	Assessed	Levy Rate	97.960	Current Tax										
Remove Cap	2024		Land Value	130,903	130,903	11%	14,399	Assessed	59,303 5,809.32										
Year Frozen			Improvements	408,217	408,217		44,904	Penalty	0										
Uncapped Value	0		Mobile Home	0	0		0	Exemption	0 0.00										
TIF Project ID	0		Total Value	539,120	539,120		59,303	Total Taxable	59,303 5,809.00										
Assessment History																			
Tax Year	Statement Number	Billed Owner			Tax Area	Total Value	Exemptions	Taxable Value	Billed Tax										
2025	2025-660106303	TRACY, BRADLEY & TONYA			3	514,927	0	56,642	5,549.00										
2024	2024-660106303	TRACY, BRADLEY & TONYA			3	522,789	0	57,507	5,525.00										
2023	2023-660106303	TRACY, BRADLEY & TONYA			3	4,470	0	492	46.00										
2022	2022-660106303	ASHER HOMES LLC			3	4,470	0	492	48.00										



Rogers

Assessment Property Record Card for Tax Year 2026

Data provided by LISA DELOZIER County Assessor

Date 04/18/2026
Time 10:45:14
Page 2

Lot Data		Square-Foot - NBHD 1039 #1	
Lot Size	0	0	
Lot Count	1		
Units Buildable			
Non-Ag Acres	0.5295		
Topography			
Street Access			
Utilities			
Amenities			0
			0
Method	Square-Foot		
Base Lot Value	23,065.00 x 5.25 = 121,050		
Factor Value			
Adjustments	1.0814		
Lot Value	130,903		



\\tsclient\T\ROB STUFF\2023-6-28\IMG_0013.JPG 6/28/2023

Residential Data	
Type	1 Single Family Residence
Condition	5 - Very Good
Quality	4 - Good
Architecture	TRAD TRADITIONAL
Style	100% One Story
Exterior Wall	95% Veneer, Masonry 5% Veneer, Stone
Base/Total Area	2,524 / 2,524
Style	100% One Story
HVAC	100% Warmed & Cooled Air
Roof Cover	1 Composition Shingle
Area on Slab	2,524
Fixture/RghIn	/
Bed/F/H Bath	3 / 2.0 / 1.0
Basement Area	
Garage Type	846 Attached Garage - Finished
Remodel	
Year/Eff Age	2023 / 1

GRM Approach

GRM Code	
Gross Rent	0.00
Indicated Value	

Multiple Regression

MRA Code	
Adjusted R	
Indicated Value	

Direct Comparables

Selection Model	A Adam Test
Adjustment Model	1 2022 Residential
Comparables	
Indicated Value	

Value Reconciliation

Selected Approach	Cost Approach		
Improvements	408,217		
Lot Value	130,903		
Indicated Value	539,120	213.60	Per SqFt
Agland Value			
Site Improvements			
Total Value	539,120	213.60	Total Value Per SqFt

Cost Approach		Manual : 01/2025	
Base Cost	113.23	Total Misc Impr	+ 15,857
Roofing Adj	+ 5.81	Garage Cost	+ 48,146
Subfloor Adj	+ -4.59	Total RCN	= 412,340
Heat/Cool Adj	+ 16.31	Depreciation (1%)	- 4,123
Plumbing Adj	+ 7.25	Lump Sums	+ 0
Basement Adj	+ 0.00	RCNLD	= 408,217
Adj Base Cost	= 138.01	Lot Value	+ 130,903
Total Area	x 2,524	Indicated Value	= 539,120
Adjusted Cost	= 348,337	Value Per SqFt	213.60

Miscellaneous Improvements

Code	Description	Sketch ID	Size	Year	Units	Unit Cost	Depr	Value
PRCH	Slab Porch - Covered	157552	8x5		40	33.07		1,323
PRCH	Slab Porch - Covered	157554	8x7		56	33.02		1,849
PRCH	Slab Porch - Covered	157555	185		185	32.35		5,985
FPPF	Fireplace - Prefabricated			2023	1	6,700.26		6,700



Rogers

Assessment Property Record Card for Tax Year 2026

Data provided by LISA DELOZIER County Assessor

Date 04/18/2026

Time 10:45:14

Page 3

Sketch Image

660106303

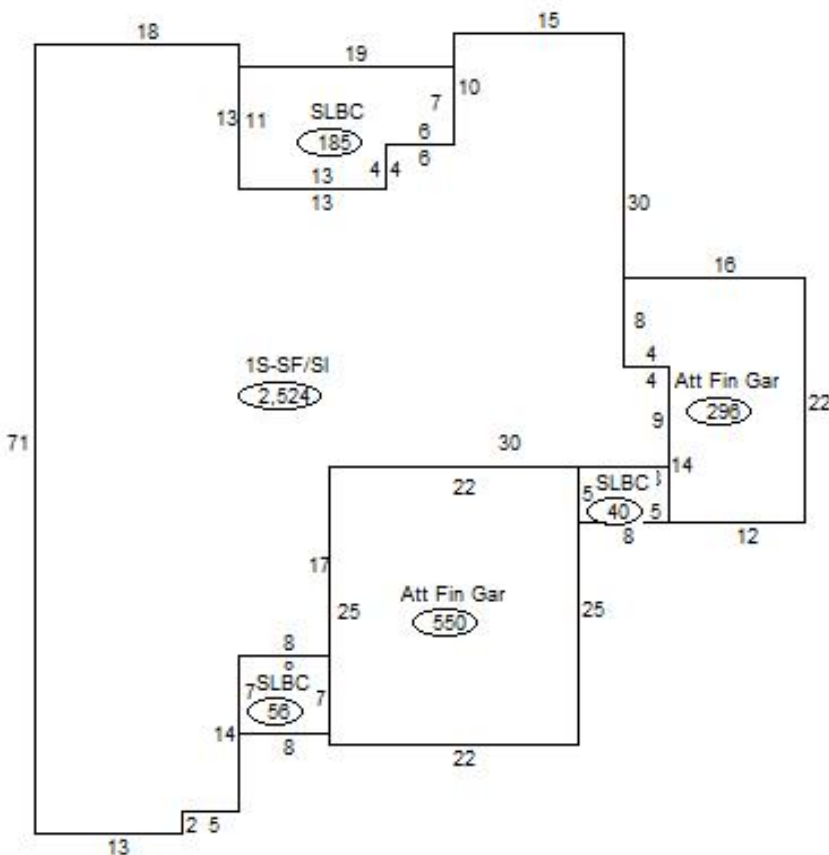

Sketch Vector Information

Sequence	Code	Type	Built Over	Scale	Section Label	Base Area	Multiplier	Total Area
1	R	1	Slab	20	1S-SF/SI	2,524	1.000	2,524
2	G	5		20	Att Fin Gar	550	1.000	550
3	M	PRCH		20	SLBC	40	1.000	40
4	G	5		20	Att Fin Gar	296	1.000	296
5	M	PRCH		20	SLBC	56	1.000	56
6	M	PRCH		20	SLBC	185	1.000	185
Total Building Area						2,524		2,524