



Rogers

Assessment Property Record Card for Tax Year 2026

Data provided by LISA DELOZIER County Assessor

Date 04/18/2026
 Time 10:47:43
 Page 1

Assessment Data				Primary Image					
Account	660106396								
Parcel ID	21N16E-2000-008-0-000-00								
Cadastral ID	24-21-16-00408								
Property Type	REAL - Real Property								
Property Class	RR	VI Area	1						
Tax Area	5 - JUSTUS RURAL/NO FIRE								
Name ID	339455								
SHERRY, RYAN & TAYLOR									
5 NORTHWEST 701 ROAD CLINTON MO 64735-0000									
Parcel Location									
Situs	22311 S 4180 RD								
Subdivision									
Lot/Block	/	Parcel Size	3.33 - Acres						
Sec/Twn/Rng	24 / 21 / 16 / 2								
Neighborhood	2116 - UNPLATTED								
School District	S009 - JUSTUS-TIAWAH SCHOOLS								
Legal Description Lat/Long: 36.28828712 -95.55993055				Building Permits					
TR 2021-019359 DESC COMM NW/C SEC; S01.3021E 1540' TO POB; N88.2235E 660.13'; S01.3021E 220'; S88.2235W 660.13'; N01.3021W 220' TO POB.				Number	Description	Opened	Closed	Amount	
				R22 403	R23 NEW SFR 2315 SQ FT	09/2022	06/2023	313,800	
Exemptions				Sale History					
Code	Type	Active	Maximum	Exemption	Bk/Pg	Grantor	Date	Price	Code
					/	THE RESERVE AT JUSTUS LLC	08/23/2022	72,500	YES
					/	SPURLOCK, JACK NELSON & KAREN-	08/02/2021	803,000	WG
Parcel Valuation									
Source	REAL		Fair Cash	Capped	Asmnt Level	Assessed	Levy Rate	83.050	Current Tax
Remove Cap	2023	Land Value	69,118	69,118	11%	7,603	Assessed	47,871	3,975.69
Year Frozen		Improvements	366,069	366,069		40,268	Penalty	0	
Uncapped Value	0	Mobile Home	0	0		0	Exemption	0	0.00
TIF Project ID	0	Total Value	435,187	435,187		47,871	Total Taxable	47,871	3,976.00
Assessment History									
Tax Year	Statement Number	Billed Owner		Tax Area	Total Value	Exemptions	Taxable Value	Billed Tax	
2025	2025-660106396	SHERRY, RYAN & TAYLOR		5	419,929	0	46,192	3,836.00	
2024	2024-660106396	SHERRY, RYAN & TAYLOR		5	436,562	0	44,866	3,744.00	
2023	2023-660106396	SHERRY, RYAN & TAYLOR		5	38,503	0	4,235	353.00	
2022	2022-660106396	SHERRY, RYAN & TAYLOR		5	710	0	78	6.00	



Rogers

Assessment Property Record Card for Tax Year 2026

Data provided by LISA DELOZIER County Assessor

Date 04/18/2026
 Time 10:47:43
 Page 2

Lot Data		Square-Foot - NBHD 2116 #1	
Lot Size	0	0	
Lot Count			
Units Buildable			
Non-Ag Acres	0		
Topography			
Street Access			
Utilities			
Amenities	LAND QUALITY		0
			0
Method	Square-Foot		
Base Lot Value	145,215.00 x .48 = 69,118		
Factor Value			
Adjustments	1.0000		
Lot Value	69,118		



\\tsclient\T\ROB STUFF\2023-6-5\IMG_0010.JPG 6/5/2023

Residential Data	
Type	1 Single Family Residence
Condition	3 - Average
Quality	4 - Good
Architecture	
Style	100% One Story
Exterior Wall	90% Veneer, Masonry 10% Frame, Siding, Wood
Base/Total Area	2,212 / 2,212
Style	100% One Story
HVAC	100% Warmed & Cooled Air
Roof Cover	1 Composition Shingle
Area on Slab	2,212
Fixture/RghIn	/
Bed/F/H Bath	4 / 3.0 /
Basement Area	
Garage Type	552 Attached Garage - Finished
Remodel	
Year/Eff Age	2023 / 2

GRM Approach

GRM Code	
Gross Rent	0.00
Indicated Value	

Multiple Regression

MRA Code	
Adjusted R	
Indicated Value	

Direct Comparables

Selection Model	A Adam Test
Adjustment Model	NewTest
Comparables	
Indicated Value	

Cost Approach		Manual : 01/2025	
Base Cost	113.86	Total Misc Impr	+ 29,860
Roofing Adj	+ 5.92	Garage Cost	+ 32,872
Subfloor Adj	+ -4.62	Total RCN	= 373,540
Heat/Cool Adj	+ 16.31	Depreciation (2%)	- 7,471
Plumbing Adj	+ 9.04	Lump Sums	+ 0
Basement Adj	+ 0.00	RCNLD	= 366,069
Adj Base Cost	= 140.51	Lot Value	+ 69,118
Total Area	x 2,212	Indicated Value	= 435,187
Adjusted Cost	= 310,808	Value Per SqFt	196.74

Value Reconciliation

Selected Approach	Cost Approach		
Improvements	366,069		
Lot Value	69,118		
Indicated Value	435,187	196.74	Per SqFt
Agland Value			
Site Improvements			
Total Value	435,187	196.74	Total Value Per SqFt

Miscellaneous Improvements

Code	Description	Sketch ID	Size	Year	Units	Unit Cost	Depr	Value
PRCH	Slab Porch - Covered	157213	364		364	31.74		11,553
PRCH	Slab Porch - Covered	157214	29x12		348	31.79		11,063
FPR1	Fireplace - Residential 1 Story		1	2023	1	7,243.87		7,244



Rogers

Assessment Property Record Card for Tax Year 2026

Data provided by LISA DELOZIER County Assessor

Date 04/18/2026
 Time 10:47:43
 Page 3

Sketch Image

660106396

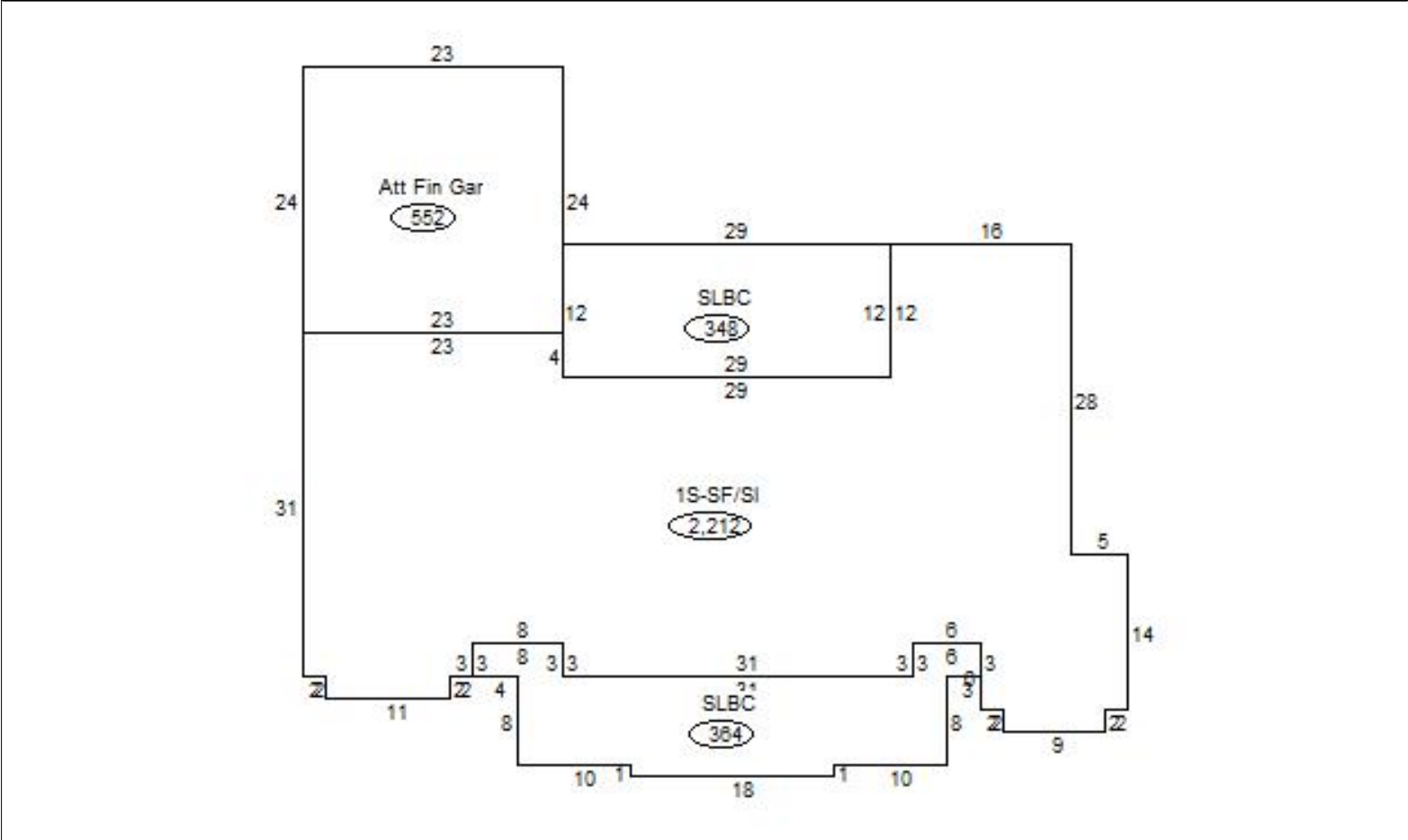

Sketch Vector Information

Sequence	Code	Type	Built Over	Scale	Section Label	Base Area	Multiplier	Total Area
1	R	1	Slab	20	1S-SF/SI	2,212	1.000	2,212
2	G	5		20	Att Fin Gar	552	1.000	552
3	M	PRCH		20	SLBC	364	1.000	364
4	M	PRCH		20	SLBC	348	1.000	348
Total Building Area						2,212		2,212