



# Rogers

## Assessment Property Record Card for Tax Year 2026

Data provided by LISA DELOZIER County Assessor

Date 04/18/2026  
 Time 10:51:00  
 Page 1

Assessment Data					Primary Image				
Account	660106609								
Parcel ID	21N16E-25-1-00000-003-0000								
Cadastral ID	25-21-16-01513								
Property Type	REAL - Real Property								
Property Class	RR	VI Area 1							
Tax Area	5 - JUSTUS RURAL/NO FIRE								
Name ID	340210								
FORBES, DENISE L & JACOB L									
23183 S LEOLA LANE CLAREMORE OK 74019-0000									
Parcel Location									
Situs	23183 S LEOLA LN								
Subdivision									
Lot/Block	/	Parcel Size	3.33 - Acres						
Sec/Twn/Rng	25 / 21 / 16 / 1								
Neighborhood	2116 - UNPLATTED								
School District	S009 - JUSTUS-TIAWAH SCHOOLS								
Legal Description Lat/Long: 36.27380065 -95.55318900									
S 220' N 440' NE SE NW									
Building Permits									
Number	Description	Opened	Closed	Amount					
R22 198	R23 NEW SFR 2075 SQ FT	05/2022	09/2022	251,800					
Exemptions									
Code	Type	Active	Maximum	Exemption					
H	Homestead	Yes	1,000	1,000					
Sale History									
Bk/Pg	Grantor	Date	Price	Code					
/	RAGLAND INVESTMENTS LLC	11/18/2022	444,000	YES					
/	RAGLAND INVESTMENTS LLC	03/08/2022	0	4					
Parcel Valuation									
Source	REAL	Fair Cash	Capped	Asmnt Level	Assessed	Levy Rate	83.050	Current Tax	
Remove Cap	2023	Land Value	175,001	165,690	11%	18,226	Assessed	47,932 3,980.75	
Year Frozen		Improvements	270,059	270,059		29,706	Penalty	0	
Uncapped Value	0	Mobile Home	0	0	0	0	Exemption	1,000 -83.00	
TIF Project ID	0	Total Value	445,060	435,749	47,932	Total Taxable	46,932	3,898.00	
Assessment History									
Tax Year	Statement Number	Billed Owner	Tax Area	Total Value	Exemptions	Taxable Value	Billed Tax		
2025	2025-660106609	FORBES, DENISE L &	5	423,058	1000	45,536	3,782.00		
2024	2024-660106609	FORBES, DENISE L &	5	441,893	1000	47,608	3,973.00		
2023	2023-660106609	FORBES, DENISE L &	5	441,893	1000	47,608	3,964.00		
2022	2022-660106609	RAGLAND INVESTMENTS LLC	5	550	0	61	5.00		



# Rogers

## Assessment Property Record Card for Tax Year 2026

Data provided by LISA DELOZIER County Assessor

Date 04/18/2026  
 Time 10:51:00  
 Page 2

Lot Data		Square-Foot - NBHD 2116 #1
Lot Size		
Lot Count		
Units Buildable		
Non-Ag Acres	3.3434	
Topography		
Street Access		
Utilities		
Amenities	LAND QUALITY	0
		0
Method	Square-Foot	
Base Lot Value	145,637.00 x .48 = 69,203	
Factor Value		
Adjustments	2.5288	
Lot Value	175,001	



\\tsclient\T\TOMMY DUNLAP\New folder (125)\IMG\_0023.JPG 12/29/2022

Residential Data	
Type	1 Single Family Residence
Condition	3 - Average
Quality	3 - Average
Architecture	
Style	100% One Story
Exterior Wall	100% Frame, Siding, Wood
Base/Total Area	2,081 / 2,081
Style	100% One Story
HVAC	100% Warmed & Cooled Air
Roof Cover	1 Composition Shingle
Area on Slab	2,081
Fixture/RghIn	/
Bed/F/H Bath	3 / 2.0 /
Basement Area	
Garage Type	588 Attached Garage - Finished
Remodel	
Year/Eff Age	2022 / 3

### GRM Approach

GRM Code	
Gross Rent	0.00
Indicated Value	

### Multiple Regression

MRA Code	
Adjusted R	
Indicated Value	

### Direct Comparables

Selection Model	A Adam Test
Adjustment Model	NewTest
Comparables	
Indicated Value	

### Value Reconciliation

Selected Approach	Cost Approach		
Improvements	270,059		
Lot Value	175,001		
Indicated Value	445,060	213.87	Per SqFt
Agland Value			
Site Improvements			
Total Value	445,060	213.87	Total Value Per SqFt

Cost Approach				Manual : 01/2025			
Base Cost	98.30	Total Misc Impr	+	8,312			
Roofing Adj	+ 4.65	Garage Cost	+	22,626			
Subfloor Adj	+ -2.19	Total RCN	=	278,411			
Heat/Cool Adj	+ 12.64	Depreciation ( 3%)	-	8,352			
Plumbing Adj	+ 5.52	Lump Sums	+	0			
Basement Adj	+ 0.00	RCNLD	=	270,059			
Adj Base Cost	= 118.92	Lot Value	+	175,001			
Total Area	x 2,081	Indicated Value	=	445,060			
Adjusted Cost	= 247,473	Value Per SqFt		213.87			

### Miscellaneous Improvements

Code	Description	Sketch ID	Size	Year	Units	Unit Cost	Depr	Value
PRCH	Slab Porch - Covered	155657	18x6		108	26.59		2,872
PRCH	Slab Porch - Covered	155658	23x9		207	26.28		5,440



# Rogers

## Assessment Property Record Card for Tax Year 2026

Data provided by LISA DELOZIER County Assessor

Date 04/18/2026  
 Time 10:51:00  
 Page 3

Sketch Image

660106609

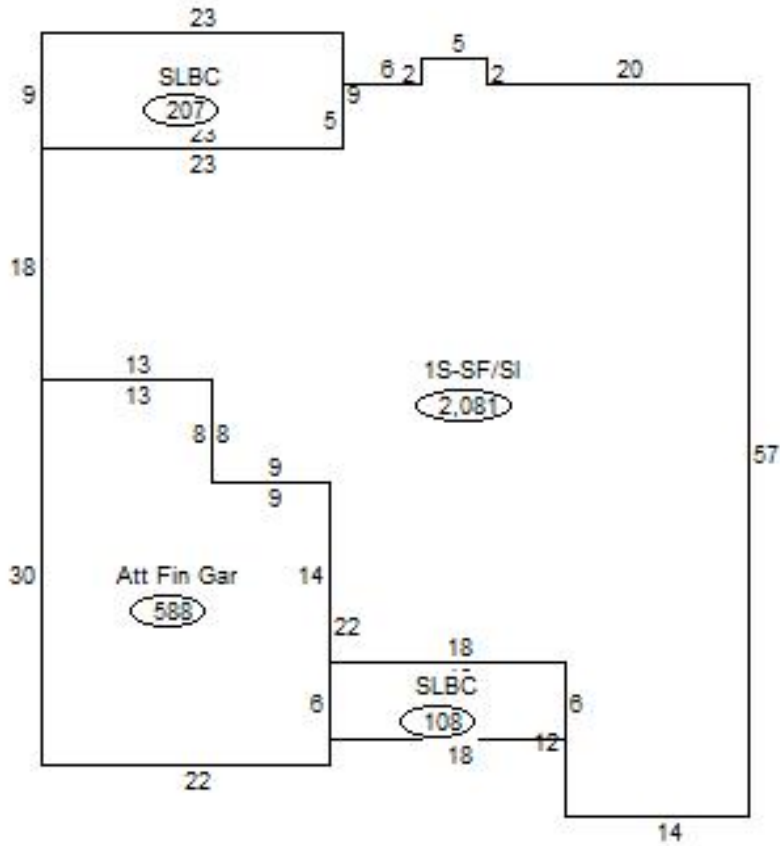

### Sketch Vector Information

Sequence	Code	Type	Built Over	Scale	Section Label	Base Area	Multiplier	Total Area
1	R	1	Slab	20	1S-SF/SI	2,081	1.000	2,081
2	G	5		20	Att Fin Gar	588	1.000	588
3	M	PRCH		20	SLBC	108	1.000	108
4	M	PRCH		20	SLBC	207	1.000	207
<b>Total Building Area</b>						2,081		2,081