



Rogers

Assessment Property Record Card for Tax Year 2026

Data provided by LISA DELOZIER County Assessor

Date 04/18/2026
Time 10:52:45
Page 1

Assessment Data				Primary Image						
Account	660106770									
Parcel ID	21N17E-31-1-00000-013-0000									
Cadastral ID	31-21-17-00533									
Property Type	REAL - Real Property									
Property Class	RR	VI Area	3							
Tax Area	5 - JUSTUS RURAL/NO FIRE									
Name ID	338174									
ENGEL, CHAD H & HOLLEIGH A										
1375 CAPRICE DR UNIT D CASTLE ROCK CO 80109-0000										
Parcel Location										
Situs	16790 E 520 RD									
Subdivision										
Lot/Block	/	Parcel Size	2.5 - Acres							
Sec/Twn/Rng	31 / 21 / 17 / 1									
Neighborhood	2117 - UNPLATTED									
School District	S009 - JUSTUS-TIAWAH SCHOOLS									
Legal Description Lat/Long: 36.26293781 -95.52941663				660106770_001.JPG 12/15/2025						
W2 W2 NW NE NE				Building Permits						
				Number	Description	Opened	Closed	Amount		
				R22 166	R23 NEW SFR 2575 SQ FT	04/2022	11/2022	350,000		
				R22 167	R23 NEW DTCH ACC BLDG 30X50	04/2022	11/2022	50,000		
Exemptions				Sale History						
Code	Type	Active	Maximum	Exemption	Bk/Pg	Grantor	Date	Price	Code	
					/	T & N PROPERTIES LLC	03/24/2022	49,500	YES	
Parcel Valuation										
Source	REAL		Fair Cash	Capped	Asmnt Level	Assessed	Levy Rate	83.050	Current Tax	
Remove Cap	2023		Land Value	43,479	43,479	11%	4,783	Assessed	60,709	5,041.88
Year Frozen			Improvements	518,859	508,419		55,926	Penalty	0	
Uncapped Value	60,062		Mobile Home	0	0		0	Exemption	0	0.00
TIF Project ID	0		Total Value	562,338	551,898		60,709	Total Taxable	60,709	5,042.00
Assessment History										
Tax Year	Statement Number	Billed Owner			Tax Area	Total Value	Exemptions	Taxable Value	Billed Tax	
2025	2025-660106770	ENGEL, CHAD H & HOLLEIGH A			5	469,450	0	51,526	4,279.00	
2024	2024-660106770	ENGEL, CHAD H & HOLLEIGH A			5	492,827	0	49,073	4,095.00	
2023	2023-660106770	ENGLE, CHAD H & HOLLEIGH A			5	424,868	0	46,735	3,892.00	
2022	2022-660106770	ENGLE, CHAD H & HOLLEIGH A			5	560	0	62	5.00	



Rogers

Assessment Property Record Card for Tax Year 2026

Data provided by LISA DELOZIER County Assessor

Date 04/18/2026
 Time 10:52:46
 Page 2

Lot Data	Square-Foot - NBHD 2117 #1	Primary Image
Lot Size		
Lot Count		
Units Buildable		
Non-Ag Acres	0	
Topography		
Street Access		
Utilities		
Amenities	LAND QUALITY	
	0	
	0	
Method	Square-Foot	
Base Lot Value	100,831.00 x .43 = 43,479	
Factor Value		
Adjustments	1.0000	
Lot Value	43,479	

Residential Data	
Type	1 Single Family Residence
Condition	3 - Average
Quality	4 - Good
Architecture	TRAD TRADITIONAL
Style	100% 1 1/2 Story Finished
Exterior Wall	25% Veneer, Masonry 75% Frame, Siding, Wood
Base/Total Area	2,568 / 2,972
Style	100% 1 1/2 Story Finished
HVAC	100% Warmed & Cooled Air
Roof Cover	1 Composition Shingle
Area on Slab	2,568
Fixture/RghIn	/
Bed/F/H Bath	4 / 3.0 / 1.0
Basement Area	
Garage Type	624 Attached Garage - Finished 3 Stalls
Remodel	
Year/Eff Age	2022 / 3

Cost Approach		Manual : 01/2025	
Base Cost	97.11	Total Misc Impr	+ 13,034
Roofing Adj	+ 5.01	Garage Cost	+ 36,248
Subfloor Adj	+ -3.95	Total RCN	= 412,966
Heat/Cool Adj	+ 16.31	Depreciation (0%)	- 0
Plumbing Adj	+ 7.89	Lump Sums	+ 0
Basement Adj	+ 0.00	RCNLD	= 412,966
Adj Base Cost	= 122.37	Lot Value	+ 43,479
Total Area	x 2,972	Indicated Value	= 456,445
Adjusted Cost	= 363,684	Value Per SqFt	153.58

GRM Approach	
GRM Code	
Gross Rent	0.00
Indicated Value	

Multiple Regression			
MRA Code	1	Test	
Adusted R	0.8445		
Indicated Value	541,692	182.27	Per SqFt

Direct Comparables	
Selection Model	1 Res
Adjustment Model	A2 AO Test
Comparables	
Indicated Value	

Value Reconciliation			
Selected Approach	Cost Approach		
Improvements	412,966		
Lot Value	43,479		
Indicated Value	456,445	153.58	Per SqFt
Agland Value			
Site Improvements	105,893		
Total Value	562,338	189.21	Total Value Per SqFt

Miscellaneous Improvements								
Code	Description	Sketch ID	Size	Year	Units	Unit Cost	Depr	Value
PRCH	Slab Porch - Covered	155939	22x10		220	32.19		7,082
PRCH	Slab Porch - Covered	155940	184		184	32.35		5,952



Rogers
Assessment Property Record Card for Tax Year 2026

Data provided by LISA DELOZIER County Assessor

Date 04/18/2026
 Time 10:52:46
 Page 3

Sketch Image

660106770

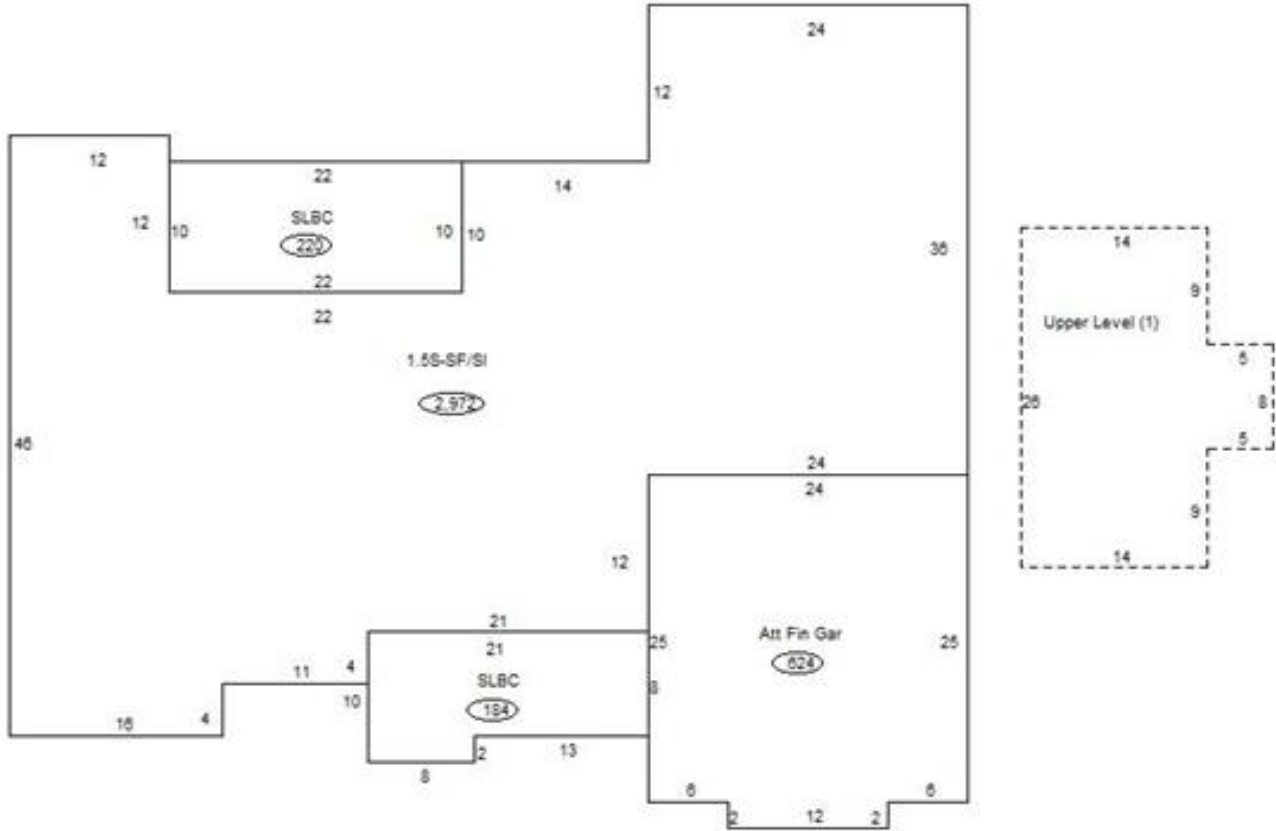

Sketch Vector Information

Sequence	Code	Type	Built Over	Scale	Section Label	Base Area	Multiplier	Total Area
1	R	5	Slab	13	1.5S-SF/SI	2,568	1.157	2,972
2	G	5		13	Att Fin Gar	624	1.000	624
3	M	PRCH		13	SLBC	220	1.000	220
4	M	PRCH		13	SLBC	184	1.000	184
5	U	^UL		13	Upper Level (1)	404	1.000	404
Total Building Area						2,568		2,972



Rogers



Assessment Property Record Card for Tax Year 2026

Data provided by LISA DELOZIER County Assessor

Date 04/18/2026
 Time 10:52:46
 Page 4

660106770

Outbuildings/Site Improvements

Building Image	Code	Description	Dimensions	Floor	Roofing	Total Units
	UTIL	Utility Building	40x50x12	Concrete	Composition Shingle	2,000
	Qual	4	Cond 3	Year 2024	Eff Age 2	
	Valuation Summary		Modifier Total	RCN	Depr (3% Phys/ % Func)	RCNLD
	Base Cost (30.96 x 2,000)		61,920	61,920	1,858	60,062
	UTIL	Utility Building	30x50x12	Concrete	Composition Shingle	1,500
	Qual	3	Cond 3	Year 2022	Eff Age 3	
	Valuation Summary		Modifier Total	RCN	Depr (5% Phys/ % Func)	RCNLD
	Base Cost (28.57 x 1,500)		42,855	42,855	2,143	40,712
	LNT0	Lean To - Attached	10x50x10	Concrete	Formed Metal	500
	Qual	3	Cond 3	Year 2022	Eff Age 3	
	Valuation Summary		Modifier Total	RCN	Depr (19% Phys/ % Func)	RCNLD
	Base Cost (12.64 x 500)		6,320	6,320	1,201	5,119