



Rogers

Assessment Property Record Card for Tax Year 2026

Data provided by LISA DELOZIER County Assessor

Date 04/18/2026
Time 10:52:51
Page 1

Assessment Data					Primary Image																																																	
Account 660106779 Parcel ID 24N15E-28-2-00000-001-0000 Cadastral ID 28-24-15-00610 Property Type REAL - Real Property Property Class RA VI Area 2 Tax Area 10 - OOLOGAH RURAL/NW FIRE Name ID 338221 BELLINGER, KYLE STEVEN 6001 E 340 RD TALALA OK 74080-0000 Parcel Location Situs 06001 E 340 RD Subdivision Lot/Block / Parcel Size 10 - Acres Sec/Twn/Rng 28 / 24 / 15 / 2 Neighborhood 4040 - TALALA AREA WEST OF LAKE School District S004 - OOLOGAH SCHOOLS																																																						
Legal Description Lat/Long: 36.53345759 -95.72190879										Building Permits <table border="1"> <thead> <tr> <th>Number</th> <th>Description</th> <th>Opened</th> <th>Closed</th> <th>Amount</th> </tr> </thead> <tbody> <tr> <td>S22</td> <td>S23 SPLIT</td> <td>03/2023</td> <td>12/2023</td> <td></td> </tr> </tbody> </table>					Number	Description	Opened	Closed	Amount	S22	S23 SPLIT	03/2023	12/2023																															
Number	Description	Opened	Closed	Amount																																																		
S22	S23 SPLIT	03/2023	12/2023																																																			
Exemptions <table border="1"> <thead> <tr> <th>Code</th> <th>Type</th> <th>Active</th> <th>Maximum</th> <th>Exemption</th> </tr> </thead> <tbody> <tr> <td>H</td> <td>Homestead</td> <td>Yes</td> <td>1,000</td> <td>1,000</td> </tr> </tbody> </table>					Code	Type	Active	Maximum	Exemption	H	Homestead	Yes	1,000	1,000	Sale History <table border="1"> <thead> <tr> <th>Bk/Pg</th> <th>Grantor</th> <th>Date</th> <th>Price</th> <th>Code</th> </tr> </thead> <tbody> <tr> <td>/</td> <td>BELLINGER, KYLE STEVEN &</td> <td>02/22/2022</td> <td>0</td> <td>4</td> </tr> </tbody> </table>					Bk/Pg	Grantor	Date	Price	Code	/	BELLINGER, KYLE STEVEN &	02/22/2022	0	4																									
Code	Type	Active	Maximum	Exemption																																																		
H	Homestead	Yes	1,000	1,000																																																		
Bk/Pg	Grantor	Date	Price	Code																																																		
/	BELLINGER, KYLE STEVEN &	02/22/2022	0	4																																																		
Parcel Valuation <table border="1"> <thead> <tr> <th>Source</th> <th>REAL</th> <th>Fair Cash</th> <th>Capped</th> <th>Asmnt Level</th> <th>Assessed</th> <th>Levy Rate</th> <th>108.182</th> <th>Current Tax</th> </tr> </thead> <tbody> <tr> <td>Remove Cap</td> <td></td> <td>Land Value</td> <td>1,033</td> <td>1,033</td> <td>11%</td> <td>114</td> <td>Assessed</td> <td>28,627 3,096.91</td> </tr> <tr> <td>Year Frozen</td> <td></td> <td>Improvements</td> <td>259,780</td> <td>259,212</td> <td></td> <td>28,513</td> <td>Penalty</td> <td>0</td> </tr> <tr> <td>Uncapped Value</td> <td>0</td> <td>Mobile Home</td> <td>0</td> <td>0</td> <td></td> <td>0</td> <td>Exemption</td> <td>1,000 -94.00</td> </tr> <tr> <td>TIF Project ID</td> <td>0</td> <td>Total Value</td> <td>260,813</td> <td>260,245</td> <td></td> <td>28,627</td> <td>Total Taxable</td> <td>27,627 3,003.00</td> </tr> </tbody> </table>										Source	REAL	Fair Cash	Capped	Asmnt Level	Assessed	Levy Rate	108.182	Current Tax	Remove Cap		Land Value	1,033	1,033	11%	114	Assessed	28,627 3,096.91	Year Frozen		Improvements	259,780	259,212		28,513	Penalty	0	Uncapped Value	0	Mobile Home	0	0		0	Exemption	1,000 -94.00	TIF Project ID	0	Total Value	260,813	260,245		28,627	Total Taxable	27,627 3,003.00
Source	REAL	Fair Cash	Capped	Asmnt Level	Assessed	Levy Rate	108.182	Current Tax																																														
Remove Cap		Land Value	1,033	1,033	11%	114	Assessed	28,627 3,096.91																																														
Year Frozen		Improvements	259,780	259,212		28,513	Penalty	0																																														
Uncapped Value	0	Mobile Home	0	0		0	Exemption	1,000 -94.00																																														
TIF Project ID	0	Total Value	260,813	260,245		28,627	Total Taxable	27,627 3,003.00																																														
Assessment History <table border="1"> <thead> <tr> <th>Tax Year</th> <th>Statement Number</th> <th>Billed Owner</th> <th>Tax Area</th> <th>Total Value</th> <th>Exemptions</th> <th>Taxable Value</th> <th>Billed Tax</th> </tr> </thead> <tbody> <tr> <td>2025</td> <td>2025-660106779</td> <td>BELLINGER, KYLE STEVEN</td> <td>10</td> <td>252,666</td> <td>1000</td> <td>26,793</td> <td>2,912.00</td> </tr> <tr> <td>2024</td> <td>2024-660106779</td> <td>BELLINGER, KYLE STEVEN</td> <td>10</td> <td>1,033</td> <td>0</td> <td>114</td> <td>12.00</td> </tr> <tr> <td>2023</td> <td>2023-660106779</td> <td>BELLINGER, ASHLEY DAWN & KYLE STEVEN</td> <td>10</td> <td>1,033</td> <td>0</td> <td>114</td> <td>12.00</td> </tr> <tr> <td>2022</td> <td>2022-660106779</td> <td>BELLINGER, ASHLEY DAWN & KYLE STEVEN</td> <td>10</td> <td>1,033</td> <td>0</td> <td>114</td> <td>12.00</td> </tr> </tbody> </table>										Tax Year	Statement Number	Billed Owner	Tax Area	Total Value	Exemptions	Taxable Value	Billed Tax	2025	2025-660106779	BELLINGER, KYLE STEVEN	10	252,666	1000	26,793	2,912.00	2024	2024-660106779	BELLINGER, KYLE STEVEN	10	1,033	0	114	12.00	2023	2023-660106779	BELLINGER, ASHLEY DAWN & KYLE STEVEN	10	1,033	0	114	12.00	2022	2022-660106779	BELLINGER, ASHLEY DAWN & KYLE STEVEN	10	1,033	0	114	12.00					
Tax Year	Statement Number	Billed Owner	Tax Area	Total Value	Exemptions	Taxable Value	Billed Tax																																															
2025	2025-660106779	BELLINGER, KYLE STEVEN	10	252,666	1000	26,793	2,912.00																																															
2024	2024-660106779	BELLINGER, KYLE STEVEN	10	1,033	0	114	12.00																																															
2023	2023-660106779	BELLINGER, ASHLEY DAWN & KYLE STEVEN	10	1,033	0	114	12.00																																															
2022	2022-660106779	BELLINGER, ASHLEY DAWN & KYLE STEVEN	10	1,033	0	114	12.00																																															



Rogers

Assessment Property Record Card for Tax Year 2026

Data provided by LISA DELOZIER County Assessor

Date 04/18/2026
 Time 10:52:51
 Page 2

Lot Data	Primary Image
Lot Size Lot Count Units Buildable Non-Ag Acres Topography Street Access Utilities Amenities LAND QUALITY Method Base Lot Value Factor Value Adjustments Lot Value	

Residential Data	
Type	1 Single Family Residence
Condition	3 - Average
Quality	3 - Average
Architecture	
Style	100% One Story
Exterior Wall	60% Veneer, Masonry 40% Frame, Siding, Wood
Base/Total Area	1,784 / 1,784
Style	100% One Story
HVAC	100% Warmed & Cooled Air
Roof Cover	1 Composition Shingle
Area on Slab	1,784
Fixture/RghIn	/
Bed/F/H Bath	3 / 2.0 /
Basement Area	
Garage Type	552 Attached Garage - Finished
Remodel	
Year/Eff Age	2024 / 2

GRM Approach	
GRM Code	
Gross Rent	0.00
Indicated Value	

Multiple Regression
MRA Code
Adusted R
Indicated Value

Direct Comparables	
Selection Model	1 Res
Adjustment Model	A2 AO Test
Comparables	
Indicated Value	

Cost Approach				Manual : 01/2025			
Base Cost	104.59	Total Misc Impr	+ 18,692	Roofing Adj	+ 4.71	Garage Cost	+ 21,141
Subfloor Adj	+ -2.26	Total RCN	= 264,153	Heat/Cool Adj	+ 12.39	Depreciation (2%)	- 5,283
Plumbing Adj	+ 6.32	Lump Sums	+ 0	Basement Adj	+ 0.00	RCNLD	= 258,870
Adj Base Cost	= 125.74	Lot Value	+ 258,870	Total Area	x 1,784	Indicated Value	= 258,870
		Value Per SqFt	145.11	Adjusted Cost	= 224,320		

Value Reconciliation			
Selected Approach	Cost Approach		
Improvements	258,870		
Lot Value			
Indicated Value	258,870	145.11	Per SqFt
Agland Value	1,033		
Site Improvements	910		
Total Value	260,813	146.20	Total Value Per SqFt

Miscellaneous Improvements								
Code	Description	Sketch ID	Size	Year	Units	Unit Cost	Depr	Value
PRCH	Porch	166207	296		296	25.48		7,542
PATC	Patio - Covered	166208	380		380	14.86		5,647
FPR1	Fireplace - Residential 1 Story			2024	1	5,503.09		5,503



Rogers
Assessment Property Record Card for Tax Year 2026

Data provided by LISA DELOZIER County Assessor

Date 04/18/2026
 Time 10:52:51
 Page 3

Sketch Image

660106779

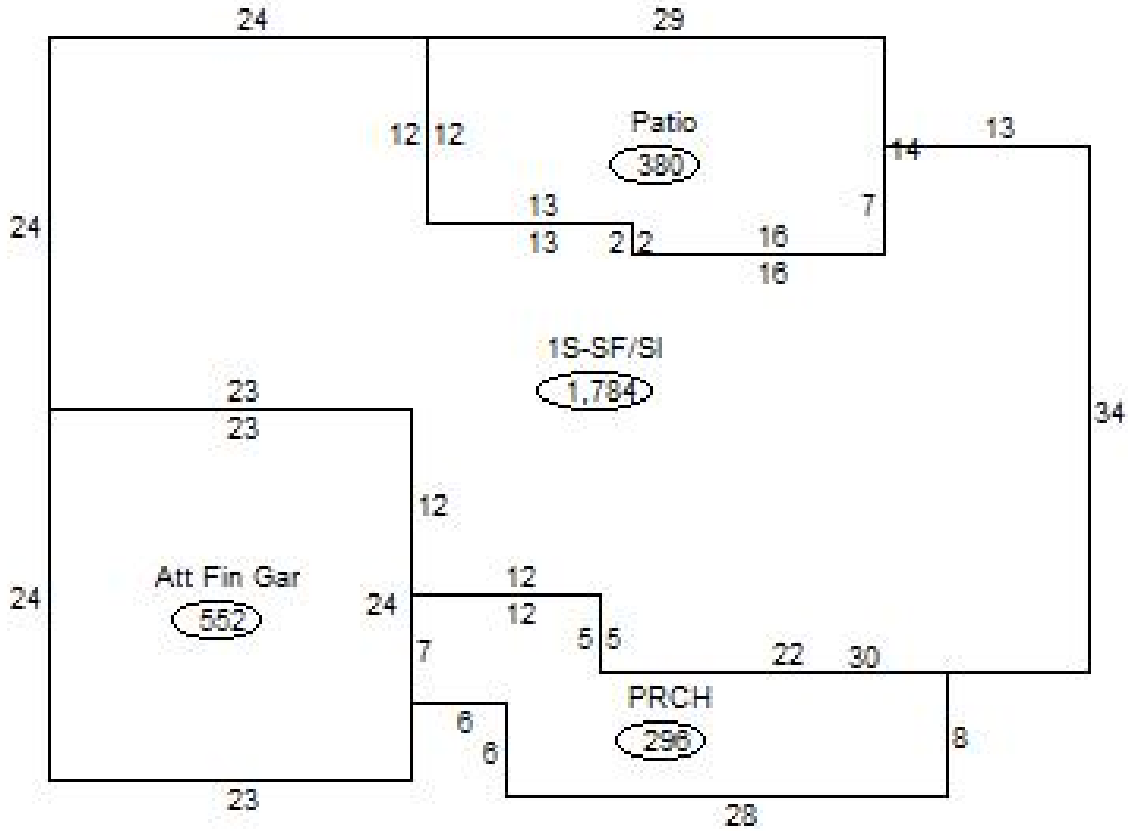

Sketch Vector Information

Sequence	Code	Type	Built Over	Scale	Section Label	Base Area	Multiplier	Total Area
1	R	1	Slab	20	1S-SF/Sl	1,784	1.000	1,784
2	G	5		20	Att Fin Gar	552	1.000	552
3	M	PRCH		20	PRCH	296	1.000	296
4	M	PATC		20	Patio	380	1.000	380
Total Building Area						1,784		1,784



Rogers

Assessment Property Record Card for Tax Year 2026

Data provided by LISA DELOZIER County Assessor

Date 04/18/2026
Time 10:52:51
Page 4

660106779

Outbuildings/Site Improvements

Building Image	Code	Description	Dimensions	Floor	Roofing	Total Units
	STF	STG FAIR	12x18x8	Base	Formed Metal	216
	Qual	1	Cond 3	Year	Eff Age	2
		Valuation Summary	Modifier Total	RCN	Depr (10% Phys/ % Func)	RCNLD
		Base Cost (4.68 x 216)	1,011		1,011	101
						910



Rogers

Assessment Property Record Card for Tax Year 2026

Data provided by LISA DELOZIER County Assessor

Date 04/18/2026
Time 10:52:51
Page 5

Agland Inventory

660106779

Soi	Description	Land Use	LPI	Adj Type	Adj Code	Acres	Use/Acre	Mkt/Acre	Use Value	Market Value
BR	BREAKS-ALLUVIAL LAND COMP	TMBR	30			1.000	54	54	54	54
BR	BREAKS-ALLUVIAL LAND COMP	TMBR	30			4.000	54	54	216	216
TMBR Totals						5.000			270	270
BR	BREAKS-ALLUVIAL LAND COMP	NTV PST	30			1.000	72	72	72	72
BR	BREAKS-ALLUVIAL LAND COMP	NTV PST	30			1.000	72	72	72	72
PAA	PARSONS SILT LOAM 0-1% SL	NTV PST	76			1.000	182	182	182	182
NTV PST Totals						3.000			326	326
DNB	DENNIS SILT LOAM 1-3% SLO	IMP PST	80			1.000	224	224	224	224
PAA	PARSONS SILT LOAM 0-1% SL	IMP PST	76			1.000	213	213	213	213
IMP PST Totals						2.000			437	437
Total Agland						10.000			1,033	1,033