



# Rogers

## Assessment Property Record Card for Tax Year 2026

Data provided by LISA DELOZIER County Assessor

Date 04/18/2026  
Time 10:55:21  
Page 1

Assessment Data				Primary Image					
Account	660107149			<p>660107149_001.JPG 6/30/2025</p>					
Parcel ID	21N16E-25-3-00000-005-0000								
Cadastral ID	25-21-16-00440								
Property Type	REAL - Real Property								
Property Class	RA	VI Area 1							
Tax Area	5 - JUSTUS RURAL/NO FIRE								
Name ID	339265								
LAMBERT, COLE THOMAS & ADDISON PAIGE									
3603 CLIFF DR SAND SPRINGS OK 74063-0000									
Parcel Location									
Situs	23360 S 4190 RD								
Subdivision									
Lot/Block	/	Parcel Size	10 - Acres						
Sec/Twn/Rng	25 / 21 / 16 / 3								
Neighborhood	2116 - UNPLATTED								
School District	S009 - JUSTUS-TIAWAH SCHOOLS								
Legal Description Lat/Long: 36.27146303 -95.54413789				Building Permits					
TR DESC 2022-012726 AS BEG NE/C NE SE; S01.2429E 225.67'; S88 2217W 602.85'; N01.2955W 721.93'; N88.2217E 603.89'; S01.2510E 496 25' TO POB.				Number	Description	Opened	Closed	Amount	
				R24 279 S22	NEW SFR 1721 SQ FT S23 SPLIT	08/2024 08/2022	06/2025 09/2022	305,000	
Exemptions				Sale History					
Code	Type	Active	Maximum	Exemption	Bk/Pg	Grantor	Date	Price	Code
					/	CHAPMAN, STEPHEN C	07/26/2022	50,000	YES
Parcel Valuation									
Source	REAL	Fair Cash	Capped	Asmnt Level	Assessed	Levy Rate	83.050	Current Tax	
Remove Cap		Land Value	1,200	1,200	11%	Assessed	30,080	2,498.14	
Year Frozen		Improvements	272,256	272,256		Penalty	0		
Uncapped Value	272,256	Mobile Home	0	0		Exemption	0	0.00	
TIF Project ID	0	Total Value	273,456	273,456		Total Taxable	30,080	2,498.00	
Assessment History									
Tax Year	Statement Number	Billed Owner			Tax Area	Total Value	Exemptions	Taxable Value	Billed Tax
2025	2025-660107149	LAMBERT, COLE THOMAS & ADDISON PAIGE			5	1,200	0	132	11.00
2024	2024-660107149	LAMBERT, COLE THOMAS & ADDISON PAIGE			5	1,200	0	132	11.00
2023	2023-660107149	LAMBERT, COLE THOMAS & ADDISON PAIGE			5	1,200	0	132	11.00
2022	2022-660107149	LAMBERT, COLE THOMAS & ADDISON PAIGE			5	1,200	0	132	11.00



# Rogers

## Assessment Property Record Card for Tax Year 2026

Data provided by LISA DELOZIER County Assessor

Date 04/18/2026  
 Time 10:55:21  
 Page 2

Lot Data	Primary Image
Lot Size Lot Count Units Buildable Non-Ag Acres Topography Street Access Utilities Amenities LAND QUALITY  Method Base Lot Value Factor Value Adjustments Lot Value	

Residential Data	
Type	1 Single Family Residence
Condition	3 - Average
Quality	3.5 - Average
Architecture	
Style	100% One Story
Exterior Wall	70% Frame, Siding, Wood 30% Veneer, Masonry
Base/Total Area	1,700 / 1,700
Style	100% One Story
HVAC	100% Warmed & Cooled Air
Roof Cover	1 Composition Shingle
Area on Slab	1,700
Fixture/RghIn	/
Bed/F/H Bath	4 / 2.0 /
Basement Area	
Garage Type	666 Attached Garage - Finished
Remodel	
Year/Eff Age	2025 / 1

660107149_001.JPG	6/30/2025
-------------------	-----------

GRM Approach	
GRM Code	
Gross Rent	0.00
Indicated Value	

Multiple Regression	
MRA Code	
Adjusted R	
Indicated Value	

Direct Comparables	
Selection Model	A Adam Test
Adjustment Model	NewTest
Comparables	
Indicated Value	

Cost Approach				Manual : 01/2025			
Base Cost	110.75	Total Misc Impr	+	14,176			
Roofing Adj	+ 5.56	Garage Cost	+	31,415			
Subfloor Adj	+ -3.58	Total RCN	=	275,006			
Heat/Cool Adj	+ 14.47	Depreciation ( 1%)	-	2,750			
Plumbing Adj	+ 7.75	Lump Sums	+	0			
Basement Adj	+ 0.00	RCNLD	=	272,256			
Adj Base Cost	= 134.95	Lot Value	+				
Total Area	x 1,700	Indicated Value	=	272,256			
Adjusted Cost	= 229,415	Value Per SqFt		160.15			

Value Reconciliation			
Selected Approach	Cost Approach		
Improvements	272,256		
Lot Value			
Indicated Value	272,256	160.15	Per SqFt
Agland Value	1,200		
Site Improvements			
Total Value	273,456	160.86	Total Value Per SqFt

Miscellaneous Improvements								
Code	Description	Sketch ID	Size	Year	Units	Unit Cost	Depr	Value
PRCH	Porch	172769	120		120	29.13		3,496
PATC	Patio - Covered	172770	245		245	19.32		4,733
FPPF	Fireplace - Prefabricated		1	2025	1	5,947.13		5,947



Sketch Image

660107149

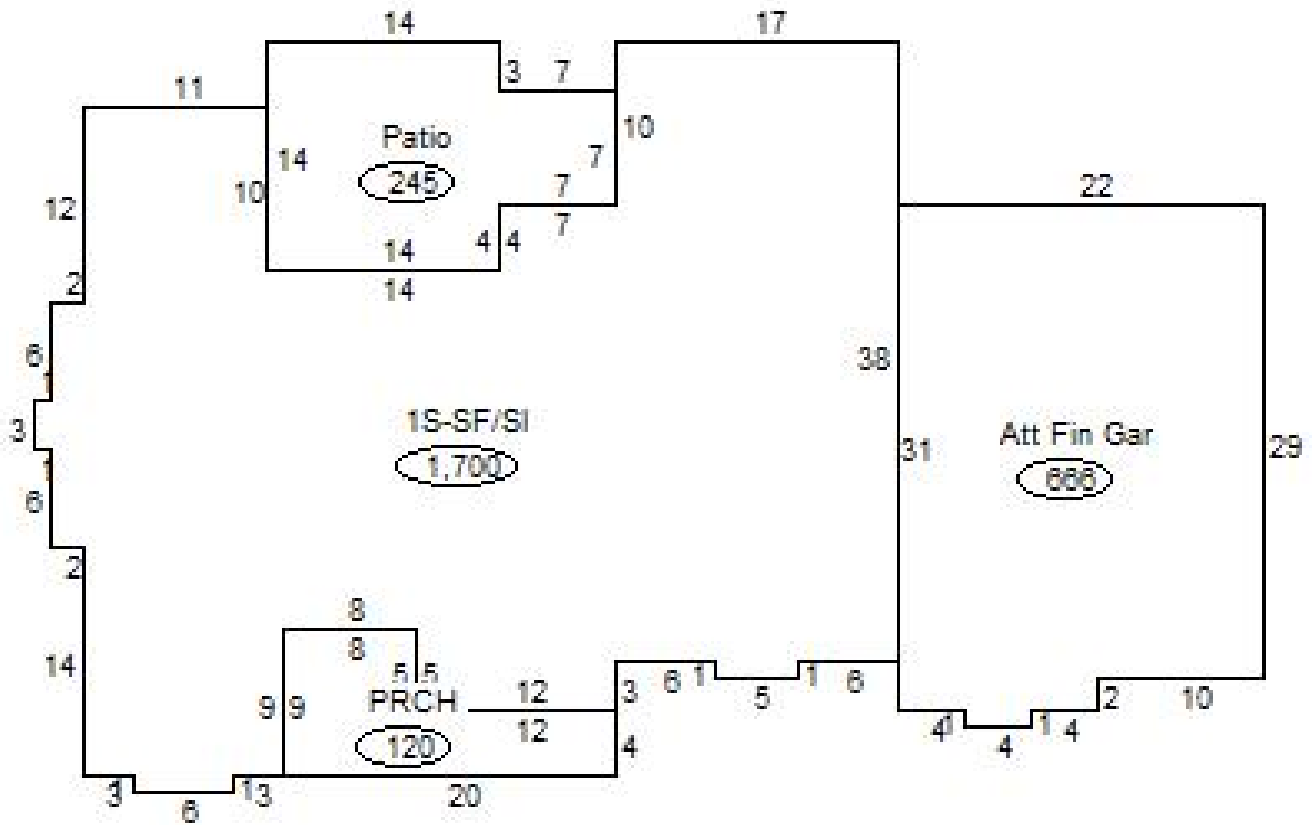

Sketch Vector Information

Sequence	Code	Type	Built Over	Scale	Section Label	Base Area	Multiplier	Total Area
1	R	1	Slab	20	1S-SF/Sl	1,700	1.000	1,700
2	G	5		20	Att Fin Gar	666	1.000	666
3	M	PRCH		20	PRCH	120	1.000	120
4	M	PATC		20	Patio	245	1.000	245
<b>Total Building Area</b>						<b>1,700</b>		<b>1,700</b>



# Rogers

## Assessment Property Record Card for Tax Year 2026

Data provided by LISA DELOZIER County Assessor

Date 04/18/2026  
Time 10:55:21  
Page 4

### Agland Inventory

660107149

Soi	Description	Land Use	LPI	Adj Type	Adj Code	Acres	Use/Acre	Mkt/Acre	Use Value	Market Value
RS	ROUGH STONY LAND	TMBR	20			3.000	36	36	108	108
<b>TMBR Totals</b>						3.000			108	108
BDC2	BATES-DENNIS SOILS 3-5% S	NTV PST	59			5.000	142	142	708	708
DNB	DENNIS SILT LOAM 1-3% SLO	NTV PST	80			2.000	192	192	384	384
<b>NTV PST Totals</b>						7.000			1,092	1,092
<b>Total Agland</b>						10.000			1,200	1,200