



# Rogers

## Assessment Property Record Card for Tax Year 2026

Data provided by LISA DELOZIER County Assessor

Date 04/18/2026  
Time 11:08:28  
Page 1

| Assessment Data  |                                 |                          |           |             | Primary Image  |   |            |           |           |            |                  |              |          |             |  |                        |            |  |                |                          |          |           |        |         |           |                 |                |                          |         |  |                                 |            |             |         |           |          |         |         |   |           |       |               |         |
|--|---------------------------------|--------------------------|-----------|-------------|--|---|------------|-----------|-----------|------------|------------------|--------------|----------|-------------|--|------------------------|------------|--|----------------|--------------------------|----------|-----------|--------|---------|-----------|-----------------|----------------|--------------------------|---------|--|---------------------------------|------------|-------------|---------|-----------|----------|---------|---------|---|-----------|-------|---------------|---------|
| <b>Account</b> 660108196<br><b>Parcel ID</b> 000223-0008-001-0-000-00<br><b>Cadastral ID</b> 35-21-14-06480<br><b>Property Type</b> REAL - Real Property<br><b>Property Class</b> RRP VI Area 4<br><b>Tax Area</b> 7 - OWASSO/LIMESTONE FIRE<br><b>Name ID</b> 344422<br>LACKEY, SCOTT & COURTNEY<br><br>17681 E PATRIOT DR<br>OWASSO OK 74055-0000<br><br><b>Parcel Location</b><br><b>Situs</b> 17681 E PATRIOT DR<br><b>Subdivision</b> COVES AT STONE CANYON PHASE I<br><b>Lot/Block</b> 0001 / 0008 Parcel Size 1 - Lots<br><b>Sec/Twn/Rng</b> 35 / 21 / 14 / 5<br><b>Neighborhood</b> 1041 - R-V01,4-SW OWASSO<br><b>School District</b> S021 - OWASSO SCHOOLS |                                 |                          |           |             | <p>660108196_001.JPG 5/31/2024</p>   |   |            |           |           |            |                  |              |          |             |  |                        |            |  |                |                          |          |           |        |         |           |                 |                |                          |         |  |                                 |            |             |         |           |          |         |         |   |           |       |               |         |
| <b>Legal Description</b> Lat/Long: 36.24978320 -95.78107170  |                                 |                          |           |             |  |   |            |           |           |            |                  |              |          |             |  |                        |            |  |                |                          |          |           |        |         |           |                 |                |                          |         |  |                                 |            |             |         |           |          |         |         |   |           |       |               |         |
| <b>Building Permits</b>  |                                 |                          |           |             | <table border="1"> <thead> <tr> <th>Number</th> <th>Description</th> <th>Opened</th> <th>Closed</th> <th>Amount</th> </tr> </thead> <tbody> <tr> <td>R23 283</td> <td>R24 NEW SFR 4024 SQ FT</td> <td>09/2023</td> <td>06/2024</td> <td>850,000</td> </tr> </tbody> </table> |   |            |           |           | Number     | Description      | Opened       | Closed   | Amount      | R23 283  | R24 NEW SFR 4024 SQ FT | 09/2023    | 06/2024  | 850,000        |                          |          |           |        |         |           |                 |                |                          |         |  |                                 |            |             |         |           |          |         |         |   |           |       |               |         |
| Number   | Description                     | Opened                   | Closed    | Amount      |  |   |            |           |           |            |                  |              |          |             |  |                        |            |  |                |                          |          |           |        |         |           |                 |                |                          |         |  |                                 |            |             |         |           |          |         |         |   |           |       |               |         |
| R23 283  | R24 NEW SFR 4024 SQ FT          | 09/2023                  | 06/2024   | 850,000     |  |   |            |           |           |            |                  |              |          |             |  |                        |            |  |                |                          |          |           |        |         |           |                 |                |                          |         |  |                                 |            |             |         |           |          |         |         |   |           |       |               |         |
| <b>Exemptions</b>  |                                 |                          |           |             | <b>Sale History</b>  |   |            |           |           |            |                  |              |          |             |  |                        |            |  |                |                          |          |           |        |         |           |                 |                |                          |         |  |                                 |            |             |         |           |          |         |         |   |           |       |               |         |
| <table border="1"> <thead> <tr> <th>Code</th> <th>Type</th> <th>Active</th> <th>Maximum</th> <th>Exemption</th> </tr> </thead> <tbody> <tr> <td>H</td> <td>Homestead</td> <td>Yes</td> <td>1,000</td> <td>1,000</td> </tr> </tbody> </table>   |                                 |                          |           |             | Code   | Type  | Active     | Maximum   | Exemption | H          | Homestead        | Yes          | 1,000    | 1,000       | <table border="1"> <thead> <tr> <th>Bk/Pg</th> <th>Grantor</th> <th>Date</th> <th>Price</th> <th>Code</th> </tr> </thead> <tbody> <tr> <td>/</td> <td>ABBEY HOMES LLC</td> <td>05/13/2024</td> <td>1,110,000</td> <td>YES</td> </tr> <tr> <td>/</td> <td>C.A.B.O. DEVELOPMENT COMPANY LI</td> <td>08/25/2023</td> <td>175,000</td> <td>15</td> </tr> </tbody> </table> |                        |            |  |                | Bk/Pg                    | Grantor  | Date      | Price  | Code    | /         | ABBEY HOMES LLC | 05/13/2024     | 1,110,000                | YES     | /  | C.A.B.O. DEVELOPMENT COMPANY LI | 08/25/2023 | 175,000     | 15      |           |          |         |         |   |           |       |               |         |
| Code   | Type                            | Active                   | Maximum   | Exemption   |  |   |            |           |           |            |                  |              |          |             |  |                        |            |  |                |                          |          |           |        |         |           |                 |                |                          |         |  |                                 |            |             |         |           |          |         |         |   |           |       |               |         |
| H  | Homestead                       | Yes                      | 1,000     | 1,000       |  |   |            |           |           |            |                  |              |          |             |  |                        |            |  |                |                          |          |           |        |         |           |                 |                |                          |         |  |                                 |            |             |         |           |          |         |         |   |           |       |               |         |
| Bk/Pg  | Grantor                         | Date                     | Price     | Code        |  |   |            |           |           |            |                  |              |          |             |  |                        |            |  |                |                          |          |           |        |         |           |                 |                |                          |         |  |                                 |            |             |         |           |          |         |         |   |           |       |               |         |
| /  | ABBEY HOMES LLC                 | 05/13/2024               | 1,110,000 | YES         |  |   |            |           |           |            |                  |              |          |             |  |                        |            |  |                |                          |          |           |        |         |           |                 |                |                          |         |  |                                 |            |             |         |           |          |         |         |   |           |       |               |         |
| /  | C.A.B.O. DEVELOPMENT COMPANY LI | 08/25/2023               | 175,000   | 15          |  |   |            |           |           |            |                  |              |          |             |  |                        |            |  |                |                          |          |           |        |         |           |                 |                |                          |         |  |                                 |            |             |         |           |          |         |         |   |           |       |               |         |
| <b>Parcel Valuation</b>  |                                 |                          |           |             |  |   |            |           |           |            |                  |              |          |             |  |                        |            |  |                |                          |          |           |        |         |           |                 |                |                          |         |  |                                 |            |             |         |           |          |         |         |   |           |       |               |         |
| <table border="1"> <thead> <tr> <th>Source</th> <th>REAL</th> </tr> </thead> <tbody> <tr> <td>Remove Cap</td> <td>2025</td> </tr> </tbody> </table>  |                                 | Source                   | REAL      | Remove Cap  | 2025   | <table border="1"> <thead> <tr> <th>Fair Cash</th> <th>Capped</th> </tr> </thead> <tbody> <tr> <td>Land Value</td> <td>262,945</td> </tr> <tr> <td>Improvements</td> <td>883,246</td> </tr> <tr> <td>Mobile Home</td> <td>0</td> </tr> <tr> <td>Total Value</td> <td>1,146,191</td> </tr> </tbody> </table> |            | Fair Cash | Capped    | Land Value | 262,945          | Improvements | 883,246  | Mobile Home | 0  | Total Value            | 1,146,191  | <table border="1"> <thead> <tr> <th>Asmnt Level</th> <th>Assessed</th> </tr> </thead> <tbody> <tr> <td>11%</td> <td>28,924</td> </tr> <tr> <td></td> <td>96,839</td> </tr> <tr> <td></td> <td>0</td> </tr> <tr> <td></td> <td>125,763</td> </tr> </tbody> </table> |                | Asmnt Level              | Assessed | 11%       | 28,924 |         | 96,839    |                 | 0              |                          | 125,763 | <table border="1"> <thead> <tr> <th>Levy Rate</th> <th>Current Tax</th> </tr> </thead> <tbody> <tr> <td>108.538</td> <td>13,650.06</td> </tr> <tr> <td>Assessed</td> <td>125,763</td> </tr> <tr> <td>Penalty</td> <td>0</td> </tr> <tr> <td>Exemption</td> <td>1,000</td> </tr> <tr> <td>Total Taxable</td> <td>124,763</td> </tr> </tbody> </table> |                                 | Levy Rate  | Current Tax | 108.538 | 13,650.06 | Assessed | 125,763 | Penalty | 0 | Exemption | 1,000 | Total Taxable | 124,763 |
| Source   | REAL                            |                          |           |             |  |   |            |           |           |            |                  |              |          |             |  |                        |            |  |                |                          |          |           |        |         |           |                 |                |                          |         |  |                                 |            |             |         |           |          |         |         |   |           |       |               |         |
| Remove Cap   | 2025                            |                          |           |             |  |   |            |           |           |            |                  |              |          |             |  |                        |            |  |                |                          |          |           |        |         |           |                 |                |                          |         |  |                                 |            |             |         |           |          |         |         |   |           |       |               |         |
| Fair Cash  | Capped                          |                          |           |             |  |   |            |           |           |            |                  |              |          |             |  |                        |            |  |                |                          |          |           |        |         |           |                 |                |                          |         |  |                                 |            |             |         |           |          |         |         |   |           |       |               |         |
| Land Value   | 262,945                         |                          |           |             |  |   |            |           |           |            |                  |              |          |             |  |                        |            |  |                |                          |          |           |        |         |           |                 |                |                          |         |  |                                 |            |             |         |           |          |         |         |   |           |       |               |         |
| Improvements   | 883,246                         |                          |           |             |  |   |            |           |           |            |                  |              |          |             |  |                        |            |  |                |                          |          |           |        |         |           |                 |                |                          |         |  |                                 |            |             |         |           |          |         |         |   |           |       |               |         |
| Mobile Home  | 0                               |                          |           |             |  |   |            |           |           |            |                  |              |          |             |  |                        |            |  |                |                          |          |           |        |         |           |                 |                |                          |         |  |                                 |            |             |         |           |          |         |         |   |           |       |               |         |
| Total Value  | 1,146,191                       |                          |           |             |  |   |            |           |           |            |                  |              |          |             |  |                        |            |  |                |                          |          |           |        |         |           |                 |                |                          |         |  |                                 |            |             |         |           |          |         |         |   |           |       |               |         |
| Asmnt Level  | Assessed                        |                          |           |             |  |   |            |           |           |            |                  |              |          |             |  |                        |            |  |                |                          |          |           |        |         |           |                 |                |                          |         |  |                                 |            |             |         |           |          |         |         |   |           |       |               |         |
| 11%  | 28,924                          |                          |           |             |  |   |            |           |           |            |                  |              |          |             |  |                        |            |  |                |                          |          |           |        |         |           |                 |                |                          |         |  |                                 |            |             |         |           |          |         |         |   |           |       |               |         |
|  | 96,839                          |                          |           |             |  |   |            |           |           |            |                  |              |          |             |  |                        |            |  |                |                          |          |           |        |         |           |                 |                |                          |         |  |                                 |            |             |         |           |          |         |         |   |           |       |               |         |
|  | 0                               |                          |           |             |  |   |            |           |           |            |                  |              |          |             |  |                        |            |  |                |                          |          |           |        |         |           |                 |                |                          |         |  |                                 |            |             |         |           |          |         |         |   |           |       |               |         |
|  | 125,763                         |                          |           |             |  |   |            |           |           |            |                  |              |          |             |  |                        |            |  |                |                          |          |           |        |         |           |                 |                |                          |         |  |                                 |            |             |         |           |          |         |         |   |           |       |               |         |
| Levy Rate  | Current Tax                     |                          |           |             |  |   |            |           |           |            |                  |              |          |             |  |                        |            |  |                |                          |          |           |        |         |           |                 |                |                          |         |  |                                 |            |             |         |           |          |         |         |   |           |       |               |         |
| 108.538  | 13,650.06                       |                          |           |             |  |   |            |           |           |            |                  |              |          |             |  |                        |            |  |                |                          |          |           |        |         |           |                 |                |                          |         |  |                                 |            |             |         |           |          |         |         |   |           |       |               |         |
| Assessed   | 125,763                         |                          |           |             |  |   |            |           |           |            |                  |              |          |             |  |                        |            |  |                |                          |          |           |        |         |           |                 |                |                          |         |  |                                 |            |             |         |           |          |         |         |   |           |       |               |         |
| Penalty  | 0                               |                          |           |             |  |   |            |           |           |            |                  |              |          |             |  |                        |            |  |                |                          |          |           |        |         |           |                 |                |                          |         |  |                                 |            |             |         |           |          |         |         |   |           |       |               |         |
| Exemption  | 1,000                           |                          |           |             |  |   |            |           |           |            |                  |              |          |             |  |                        |            |  |                |                          |          |           |        |         |           |                 |                |                          |         |  |                                 |            |             |         |           |          |         |         |   |           |       |               |         |
| Total Taxable  | 124,763                         |                          |           |             |  |   |            |           |           |            |                  |              |          |             |  |                        |            |  |                |                          |          |           |        |         |           |                 |                |                          |         |  |                                 |            |             |         |           |          |         |         |   |           |       |               |         |
| <b>Assessment History</b>  |                                 |                          |           |             |  |   |            |           |           |            |                  |              |          |             |  |                        |            |  |                |                          |          |           |        |         |           |                 |                |                          |         |  |                                 |            |             |         |           |          |         |         |   |           |       |               |         |
| <table border="1"> <thead> <tr> <th>Tax Year</th> <th>Statement Number</th> <th>Billed Owner</th> <th>Tax Area</th> <th>Total Value</th> <th>Exemptions</th> <th>Taxable Value</th> <th>Billed Tax</th> </tr> </thead> <tbody> <tr> <td>2025</td> <td>2025-660108196</td> <td>LACKEY, SCOTT &amp; COURTNEY</td> <td>7</td> <td>1,110,000</td> <td>1000</td> <td>121,100</td> <td>13,155.00</td> </tr> <tr> <td>2024</td> <td>2024-660108196</td> <td>LACKEY, SCOTT &amp; COURTNEY</td> <td>7</td> <td>8,341</td> <td>0</td> <td>918</td> <td>101.00</td> </tr> </tbody> </table>   |                                 |                          |           |             |  |   |            |           |           | Tax Year   | Statement Number | Billed Owner | Tax Area | Total Value | Exemptions   | Taxable Value          | Billed Tax | 2025   | 2025-660108196 | LACKEY, SCOTT & COURTNEY | 7        | 1,110,000 | 1000   | 121,100 | 13,155.00 | 2024            | 2024-660108196 | LACKEY, SCOTT & COURTNEY | 7       | 8,341  | 0                               | 918        | 101.00      |         |           |          |         |         |   |           |       |               |         |
| Tax Year   | Statement Number                | Billed Owner             | Tax Area  | Total Value | Exemptions   | Taxable Value   | Billed Tax |           |           |            |                  |              |          |             |  |                        |            |  |                |                          |          |           |        |         |           |                 |                |                          |         |  |                                 |            |             |         |           |          |         |         |   |           |       |               |         |
| 2025   | 2025-660108196                  | LACKEY, SCOTT & COURTNEY | 7         | 1,110,000   | 1000   | 121,100   | 13,155.00  |           |           |            |                  |              |          |             |  |                        |            |  |                |                          |          |           |        |         |           |                 |                |                          |         |  |                                 |            |             |         |           |          |         |         |   |           |       |               |         |
| 2024   | 2024-660108196                  | LACKEY, SCOTT & COURTNEY | 7         | 8,341       | 0  | 918   | 101.00     |           |           |            |                  |              |          |             |  |                        |            |  |                |                          |          |           |        |         |           |                 |                |                          |         |  |                                 |            |             |         |           |          |         |         |   |           |       |               |         |



# Rogers

## Assessment Property Record Card for Tax Year 2026

Data provided by LISA DELOZIER County Assessor

Date 04/18/2026  
Time 11:08:28  
Page 2

| Lot Data        | Square-Foot - NBHD 1041 #1 | Primary Image |
|-----------------|----------------------------|---------------|
| Lot Size        | 0 0                        |               |
| Lot Count       | 1                          |               |
| Units Buildable |                            |               |
| Non-Ag Acres    | 0.7475                     |               |
| Topography      |                            |               |
| Street Access   |                            |               |
| Utilities       |                            |               |
| Amenities       | LOT TYPE 0<br>GATED 0      |               |
| Method          | Square-Foot                |               |
| Base Lot Value  | 32,560.00 x 4.35 = 141,636 |               |
| Factor Value    |                            |               |
| Adjustments     | 1.8565                     |               |
| Lot Value       | 262,945                    |               |

| Residential Data |                                     |
|------------------|-------------------------------------|
| Type             | 1 Single Family Residence           |
| Condition        | 5 - Very Good                       |
| Quality          | 6.5 - Excellent                     |
| Architecture     |                                     |
| Style            | 100% One Story                      |
| Exterior Wall    | 90% Frame, Stucco 10% Veneer, Stone |
| Base/Total Area  | 3,977 / 3,977                       |
| Style            | 100% One Story                      |
| HVAC             | 100% Warmed & Cooled Air            |
| Roof Cover       | 1 Composition Shingle               |
| Area on Slab     | 3,977                               |
| Fixture/RghIn    | /                                   |
| Bed/F/H Bath     | 4 / 4.0 / 1.0                       |
| Basement Area    |                                     |
| Garage Type      | 1,249 Attached Garage - Finished    |
| Remodel          |                                     |
| Year/Eff Age     | 2024 / 2                            |

|                   |           |
|-------------------|-----------|
| 660108196_001.JPG | 5/31/2024 |
|-------------------|-----------|

| GRM Approach    |      |
|-----------------|------|
| GRM Code        |      |
| Gross Rent      | 0.00 |
| Indicated Value |      |

| Multiple Regression |         |             |          |
|---------------------|---------|-------------|----------|
| MRA Code            | AO3     | Residential |          |
| Adusted R           | 0.8747  |             |          |
| Indicated Value     | 951,483 | 239.25      | Per SqFt |

| Direct Comparables |                    |
|--------------------|--------------------|
| Selection Model    | A Adam Test        |
| Adjustment Model   | 1 2022 Residential |
| Comparables        | 6                  |
| Indicated Value    | 987,060 Per SqFt   |

| Value Reconciliation |               |        |                      |
|----------------------|---------------|--------|----------------------|
| Selected Approach    | Cost Approach |        |                      |
| Improvements         | 883,246       |        |                      |
| Lot Value            | 262,945       |        |                      |
| Indicated Value      | 1,146,191     | 288.20 | Per SqFt             |
| Agland Value         |               |        |                      |
| Site Improvements    |               |        |                      |
| Total Value          | 1,146,191     | 288.20 | Total Value Per SqFt |

| Cost Approach |           |                    |             | Manual : 01/2025 |  |  |  |
|---------------|-----------|--------------------|-------------|------------------|--|--|--|
| Base Cost     | 141.31    | Total Misc Impr    | + 54,240    |                  |  |  |  |
| Roofing Adj   | + 7.66    | Garage Cost        | + 165,218   |                  |  |  |  |
| Subfloor Adj  | + -12.89  | Total RCN          | = 892,168   |                  |  |  |  |
| Heat/Cool Adj | + 22.94   | Depreciation ( 1%) | - 8,922     |                  |  |  |  |
| Plumbing Adj  | + 10.13   | Lump Sums          | + 0         |                  |  |  |  |
| Basement Adj  | + 0.00    | RCNLD              | = 883,246   |                  |  |  |  |
| Adj Base Cost | = 169.15  | Lot Value          | + 262,945   |                  |  |  |  |
| Total Area    | x 3,977   | Indicated Value    | = 1,146,191 |                  |  |  |  |
| Adjusted Cost | = 672,710 | Value Per SqFt     | 288.20      |                  |  |  |  |

| Miscellaneous Improvements |                                 |           |      |      |       |           |      |        |
|----------------------------|---------------------------------|-----------|------|------|-------|-----------|------|--------|
| Code                       | Description                     | Sketch ID | Size | Year | Units | Unit Cost | Depr | Value  |
| PRCH                       | Slab Porch - Covered            | 160264    | 109  |      | 109   | 46.51     |      | 5,070  |
| PRCH                       | Slab Porch - Covered            | 160265    | 689  |      | 689   | 43.37     |      | 29,882 |
| FPR1                       | Fireplace - Residential 1 Story |           | 1    | 2024 | 1     | 9,658.49  |      | 9,658  |
| ODFP                       | Outdoor Fireplace/Firepit       |           | 1    | 2024 | 1     | 9,630.41  |      | 9,630  |



# Rogers

## Assessment Property Record Card for Tax Year 2026

Data provided by LISA DELOZIER County Assessor

Date 04/18/2026  
 Time 11:08:28  
 Page 3

### Sketch Image

660108196

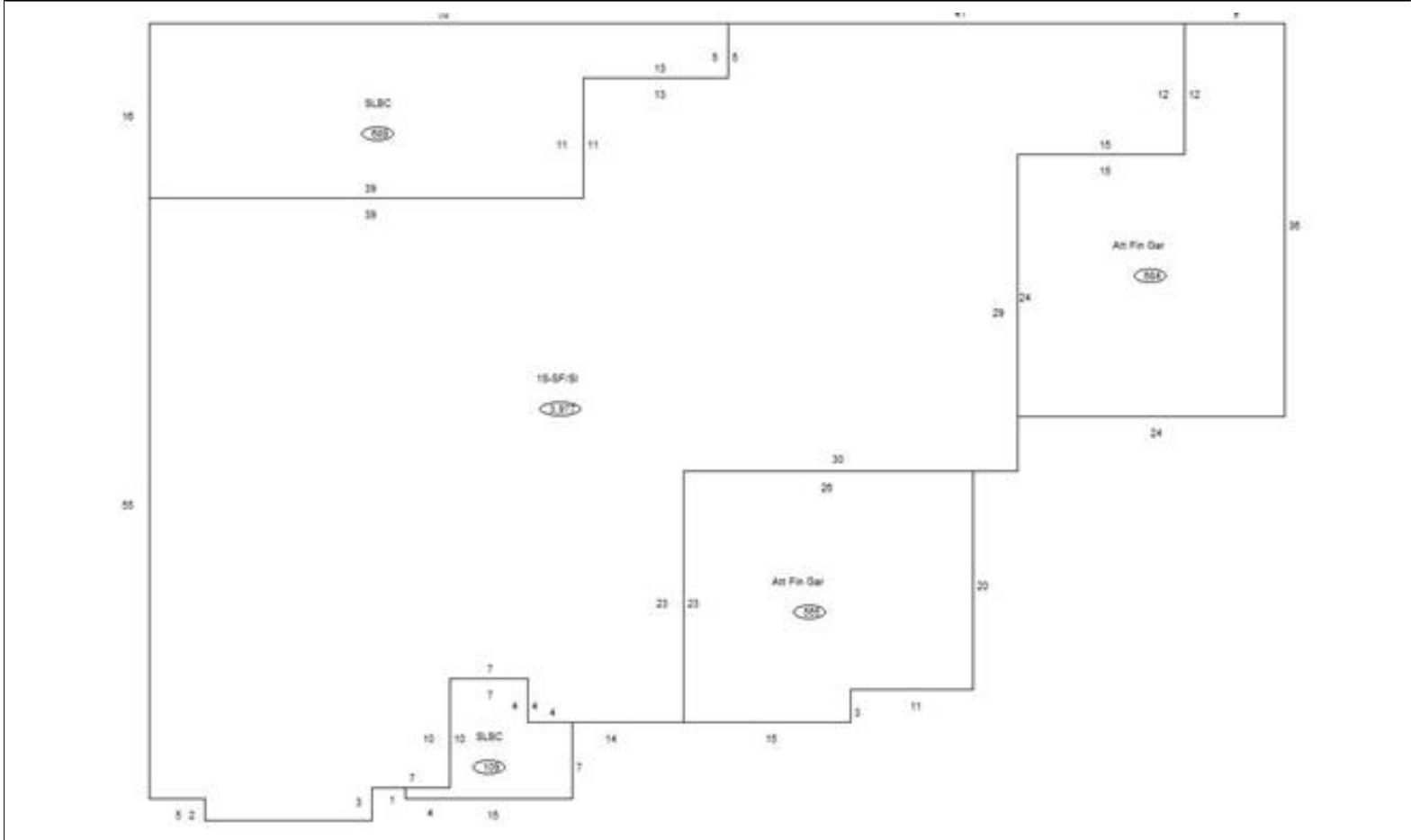

### Sketch Vector Information

| Sequence                   | Code | Type | Built Over | Scale | Section Label | Base Area    | Multiplier | Total Area   |
|----------------------------|------|------|------------|-------|---------------|--------------|------------|--------------|
| 1                          | R    | 1    | Slab       | 10    | 1S-SF/SI      | 3,977        | 1.000      | 3,977        |
| 2                          | G    | 5    |            | 10    | Att Fin Gar   | 565          | 1.000      | 565          |
| 3                          | G    | 5    |            | 10    | Att Fin Gar   | 684          | 1.000      | 684          |
| 4                          | M    | PRCH |            | 10    | SLBC          | 109          | 1.000      | 109          |
| 5                          | M    | PRCH |            | 10    | SLBC          | 689          | 1.000      | 689          |
| <b>Total Building Area</b> |      |      |            |       |               | <b>3,977</b> |            | <b>3,977</b> |