



# Rogers

## Assessment Property Record Card for Tax Year 2026

Data provided by LISA DELOZIER County Assessor

Date 04/18/2026  
Time 11:10:15  
Page 1

Assessment Data					Primary Image																			
<b>Account</b> 660108273 <b>Parcel ID</b> 000173-0001-014-0-000-00 <b>Cadastral ID</b> 35-23-14-02240 <b>Property Type</b> REAL - Real Property <b>Property Class</b> RRP VI Area 2 <b>Tax Area</b> 10 - OOLOGAH RURAL/NW FIRE <b>Name ID</b> 346392 SZWEDO, CATHERINE D  2612 CROSS CREEK DR OOLOGAH OK 74053-0000  <b>Parcel Location</b> <b>Situs</b> 02612 CROSSCREEK DR <b>Subdivision</b> CLEAR CREEK AT WOODSIDE PHASE V <b>Lot/Block</b> 0014 / 0001 Parcel Size 1 - Lots <b>Sec/Twn/Rng</b> 35 / 23 / 14 / 5 <b>Neighborhood</b> 1021 - R-V02-NW OOLOGAH <b>School District</b> S004 - OOLOGAH SCHOOLS					 <p>660108273_001.JPG 4/21/2025</p>																			
<b>Legal Description</b> Lat/Long: 36.42950234 -95.78414317 LOT 14 BLOCK 1 CLEAR CREEK AT WOODSIDE PHASE V																								
<b>Exemptions</b>					<b>Building Permits</b>																			
					<table border="1"> <thead> <tr> <th>Number</th> <th>Description</th> <th>Opened</th> <th>Closed</th> <th>Amount</th> </tr> </thead> <tbody> <tr> <td>R24 265</td> <td>NEW SFR 2711 SQ FT</td> <td>08/2024</td> <td>04/2025</td> <td>230,000</td> </tr> </tbody> </table>					Number	Description	Opened	Closed	Amount	R24 265	NEW SFR 2711 SQ FT	08/2024	04/2025	230,000					
Number	Description	Opened	Closed	Amount																				
R24 265	NEW SFR 2711 SQ FT	08/2024	04/2025	230,000																				
<table border="1"> <thead> <tr> <th>Code</th> <th>Type</th> <th>Active</th> <th>Maximum</th> <th>Exemption</th> </tr> </thead> <tbody> <tr> <td></td> <td></td> <td></td> <td></td> <td></td> </tr> </tbody> </table>					Code	Type	Active	Maximum	Exemption						<b>Sale History</b>									
Code	Type	Active	Maximum	Exemption																				
					<table border="1"> <thead> <tr> <th>Bk/Pg</th> <th>Grantor</th> <th>Date</th> <th>Price</th> <th>Code</th> </tr> </thead> <tbody> <tr> <td>/</td> <td>EXECUTIVE HOMES LLC</td> <td>02/12/2025</td> <td>556,500</td> <td>15</td> </tr> <tr> <td>/</td> <td>DOUBLE H PROPERTIES LLC</td> <td>08/02/2024</td> <td>180,000</td> <td>WB</td> </tr> </tbody> </table>					Bk/Pg	Grantor	Date	Price	Code	/	EXECUTIVE HOMES LLC	02/12/2025	556,500	15	/	DOUBLE H PROPERTIES LLC	08/02/2024	180,000	WB
Bk/Pg	Grantor	Date	Price	Code																				
/	EXECUTIVE HOMES LLC	02/12/2025	556,500	15																				
/	DOUBLE H PROPERTIES LLC	08/02/2024	180,000	WB																				
<b>Parcel Valuation</b>																								
Source	REAL		Fair Cash	Capped	Asmnt Level	Assessed	Levy Rate	108.182	Current Tax															
Remove Cap	2026	Land Value	130,448	130,448	11%	14,349	Assessed	61,620	6,666.15															
Year Frozen		Improvements	429,733	429,733		47,271	Penalty	0																
Uncapped Value	429,733	Mobile Home	0	0		0	Exemption	0	0.00															
TIF Project ID	0	Total Value	560,181	560,181		61,620	Total Taxable	61,620	6,666.00															
<b>Assessment History</b>																								
Tax Year	Statement Number	Billed Owner			Tax Area	Total Value	Exemptions	Taxable Value	Billed Tax															
2025	2025-660108273	SZWEDO, CATHERINE D			10	6,422	0	706	76.00															
2024	2024-660108273	EXECUTIVE HOMES LLC			10	6,422	0	706	74.00															



# Rogers

## Assessment Property Record Card for Tax Year 2026

Data provided by LISA DELOZIER County Assessor

Date 04/18/2026  
 Time 11:10:15  
 Page 2

Lot Data		Square-Foot - NBHD 1021 #1	
Lot Size	0	0	
Lot Count	1		
Units Buildable			
Non-Ag Acres	1.5818		
Topography			
Street Access			
Utilities			
Amenities	LAND QUALITY		0
			0
Method	Square-Foot		
Base Lot Value	68,904.00 x 1.31 = 90,545		
Factor Value			
Adjustments	1.4407		
Lot Value	130,448		



660108273\_001.JPG 4/21/2025

Residential Data	
Type	1 Single Family Residence
Condition	3 - Average
Quality	4 - Good
Architecture	
Style	100% One Story
Exterior Wall	95% Veneer, Masonry 5% Veneer, Stone
Base/Total Area	2,708 / 2,708
Style	100% One Story
HVAC	100% Warmed & Cooled Air
Roof Cover	1 Composition Shingle
Area on Slab	2,708
Fixture/RghIn	/
Bed/F/H Bath	4 / 2.0 / 1.0
Basement Area	
Garage Type	838 Attached Garage - Finished
Remodel	
Year/Eff Age	2025 / 1

### GRM Approach

GRM Code	
Gross Rent	0.00
Indicated Value	

### Multiple Regression

MRA Code	
Adjusted R	
Indicated Value	

### Direct Comparables

Selection Model	A Adam Test
Adjustment Model	1 2022 Residential
Comparables	
Indicated Value	

### Value Reconciliation

Selected Approach	Cost Approach		
Improvements	429,733		
Lot Value	130,448		
Indicated Value	560,181	206.86	Per SqFt
Agland Value			
Site Improvements			
Total Value	560,181	206.86	Total Value Per SqFt

### Cost Approach Manual : 01/2025

Base Cost	111.62	Total Misc Impr	+	18,203
Roofing Adj	+ 5.74	Garage Cost	+	47,691
Subfloor Adj	+ -4.46	Total RCN	=	434,074
Heat/Cool Adj	+ 16.31	Depreciation ( 1%)	-	4,341
Plumbing Adj	+ 6.75	Lump Sums	+	0
Basement Adj	+ 0.00	RCNLD	=	429,733
Adj Base Cost	= 135.96	Lot Value	+	130,448
Total Area	x 2,708	Indicated Value	=	560,181
Adjusted Cost	= 368,180	Value Per SqFt		206.86

### Miscellaneous Improvements

Code	Description	Sketch ID	Size	Year	Units	Unit Cost	Depr	Value
PRCH	Porch	172024	51		51	33.03		1,685
PRCH	Porch	172025	17x6		102	32.87		3,353
PATC	Patio - Covered	172026	21x16		336	19.24		6,465
FPPF	Fireplace - Prefabricated		1	2025	1	6,700.26		6,700



**Rogers**  
**Assessment Property Record Card for Tax Year 2026**

Data provided by LISA DELOZIER County Assessor

Date 04/18/2026  
 Time 11:10:15  
 Page 3

Sketch Image

660108273

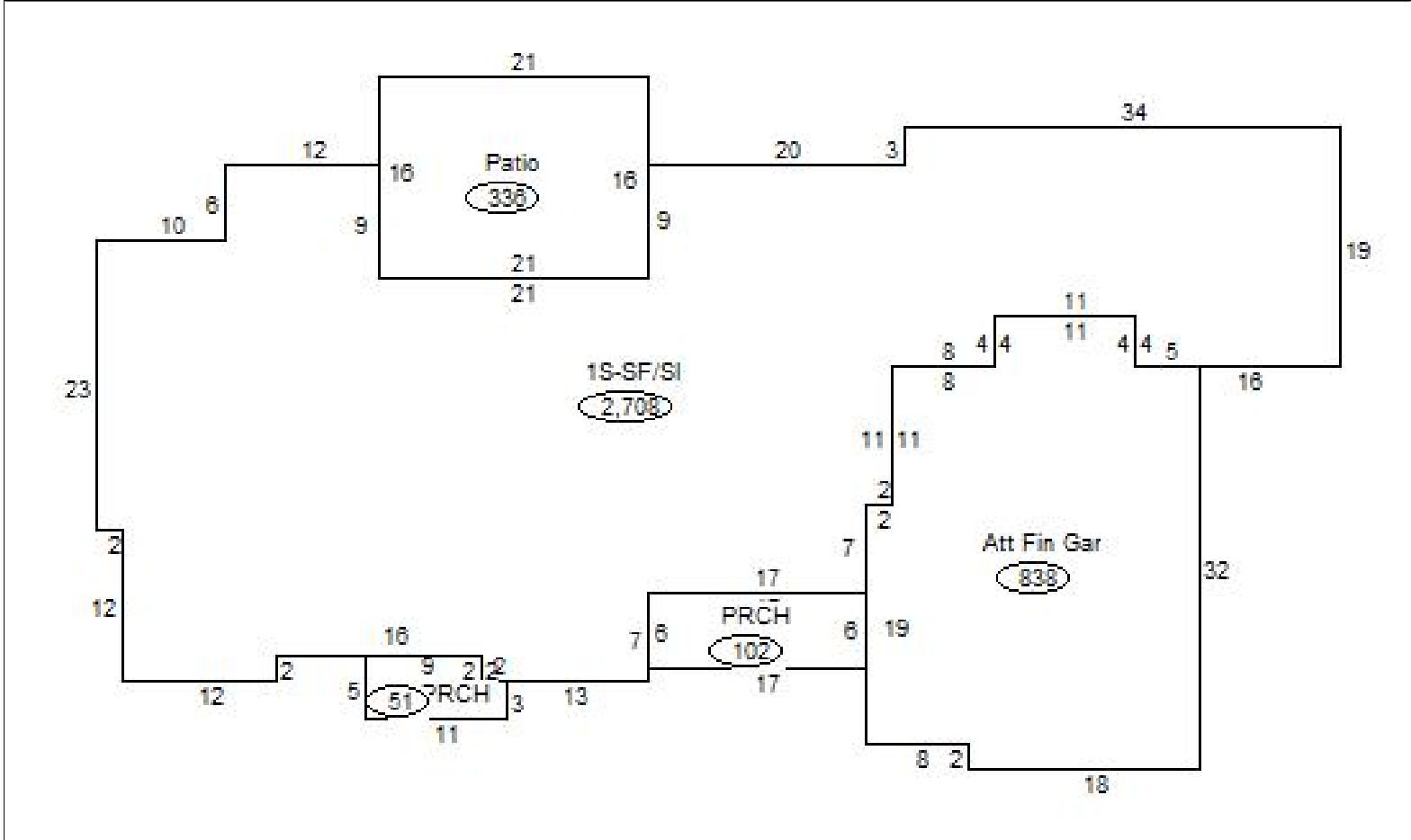

**Sketch Vector Information**

Sequence	Code	Type	Built Over	Scale	Section Label	Base Area	Multiplier	Total Area
1	R	1	Slab	20	1S-SF/Sl	2,708	1.000	2,708
2	G	5		20	Att Fin Gar	838	1.000	838
3	M	PRCH		20	PRCH	51	1.000	51
4	M	PRCH		20	PRCH	102	1.000	102
5	M	PATC		20	Patio	336	1.000	336
<b>Total Building Area</b>						<b>2,708</b>		<b>2,708</b>