



# Rogers

## Assessment Property Record Card for Tax Year 2026

Data provided by LISA DELOZIER County Assessor

Date 04/18/2026  
Time 11:20:54  
Page 1

Assessment Data					Primary Image									
Account	660109137				<p>660109137_001.JPG 9/11/2025</p>									
Parcel ID	000959-0003-006-0-000-00													
Cadastral ID	14-21-14-04210													
Property Type	REAL - Real Property													
Property Class	RRP	VI Area	4											
Tax Area	3 - OWASSO RURAL/NO FIRE													
Name ID	347784													
PATTILLO, PHILLIP S														
10223 N 164TH E AVE OWASSO OK 74055-0000														
Parcel Location														
Situs	10223 N 164TH E AVE													
Subdivision	WOODLANDS AT ELM CREEK BLOCKS 1-5 (THE)													
Lot/Block	0006 / 0003	Parcel Size	1 - Lots											
Sec/Twn/Rng	14 / 21 / 14 / 5													
Neighborhood	1042 - R-V03-SW OWASSO													
School District	S021 - OWASSO SCHOOLS													
Legal Description Lat/Long: 36.30339040 -95.79120362														
LOT 6 BLOCK 3 THE WOODLANDS AT ELM CREEK BLOCKS 1-5														
Building Permits														
<table border="1"> <thead> <tr> <th>Number</th> <th>Description</th> <th>Opened</th> <th>Closed</th> <th>Amount</th> </tr> </thead> <tbody> <tr> <td>R24 438</td> <td>NEW SFR 3701 SQ FT</td> <td>12/2024</td> <td>09/2025</td> <td>475,834</td> </tr> </tbody> </table>					Number	Description	Opened	Closed	Amount	R24 438	NEW SFR 3701 SQ FT	12/2024	09/2025	475,834
Number	Description	Opened	Closed	Amount										
R24 438	NEW SFR 3701 SQ FT	12/2024	09/2025	475,834										
Exemptions														
Sale History														
Code	Type	Active	Maximum	Exemption	Bk/Pg	Grantor	Date	Price	Code					
					/	CAPITAL HOMES RES GRP LLC	08/06/2025	555,500	15					
					/	ELM CREEK DEV CO LLC	04/08/2025	0	5					
Parcel Valuation														
Source	REAL		Fair Cash	Capped	Asmnt Level	Assessed	Levy Rate	97.960	Current Tax					
Remove Cap	2026	Land Value	125,533	125,533	11%	13,809	Assessed	61,347	6,009.55					
Year Frozen		Improvements	432,161	432,161		47,538	Penalty	0						
Uncapped Value	432,161	Mobile Home	0	0		0	Exemption	0	0.00					
TIF Project ID	0	Total Value	557,694	557,694		61,347	Total Taxable	61,347	6,010.00					
Assessment History														
Tax Year	Statement Number	Billed Owner			Tax Area	Total Value	Exemptions	Taxable Value	Billed Tax					
2025	2025-660109137	PATTILLO, PHILLIP S			3	16,960	0	1,866	183.00					



# Rogers

## Assessment Property Record Card for Tax Year 2026

Data provided by LISA DELOZIER County Assessor

Date 04/18/2026  
Time 11:20:54  
Page 2

Lot Data	Square-Foot - NBHD 1042 #1	Primary Image
Lot Size	0 0	
Lot Count	1	
Units Buildable		
Non-Ag Acres	0.6843	
Topography		
Street Access		
Utilities		
Amenities		
Method	Square-Foot	
Base Lot Value	29,810.00 x 4.21 = 125,533	
Factor Value		
Adjustments		
Lot Value	125,533	

Residential Data	
Type	1 Single Family Residence
Condition	3 - Average
Quality	4 - Good
Architecture	
Style	100% One Story
Exterior Wall	75% Frame, Siding, Wood 25% Veneer, Masonry
Base/Total Area	2,768 / 2,768
Style	100% One Story
HVAC	100% Warmed & Cooled Air
Roof Cover	1 Composition Shingle
Area on Slab	2,768
Fixture/RghIn	/
Bed/F/H Bath	5 / 2.0 / 1.0
Basement Area	
Garage Type	926 Attached Garage - Finished
Remodel	
Year/Eff Age	2025 / 1



660109137\_001.JPG 9/11/2025

GRM Approach	
GRM Code	
Gross Rent	0.00
Indicated Value	

Multiple Regression	
MRA Code	
Adjusted R	
Indicated Value	

Direct Comparables	
Selection Model	A Adam Test
Adjustment Model	1 2022 Residential
Comparables	
Indicated Value	

Cost Approach		Manual : 01/2025	
Base Cost	104.81	Total Misc Impr	+ 26,617
Roofing Adj	+ 5.73	Garage Cost	+ 52,699
Subfloor Adj	+ -4.40	Total RCN	= 436,526
Heat/Cool Adj	+ 16.31	Depreciation ( 1%)	- 4,365
Plumbing Adj	+ 6.60	Lump Sums	+ 0
Basement Adj	+ 0.00	RCNLD	= 432,161
Adj Base Cost	= 129.05	Lot Value	+ 125,533
Total Area	x 2,768	Indicated Value	= 557,694
Adjusted Cost	= 357,210	Value Per SqFt	201.48

Value Reconciliation			
Selected Approach	Cost Approach		
Improvements	432,161		
Lot Value	125,533		
Indicated Value	557,694	201.48	Per SqFt
Agland Value			
Site Improvements			
Total Value	557,694	201.48	Total Value Per SqFt

Miscellaneous Improvements								
Code	Description	Sketch ID	Size	Year	Units	Unit Cost	Depr	Value
PRCH	Porch	173870	288		288	31.98		9,210
PATC	Patio - Covered	173871	24x13		312	19.39		6,050
PATO	Patio - Open	173872	432		432	10.78		4,657
FPPF	Fireplace - Prefabricated		1	2025	1	6,700.26		6,700



**Rogers**  
**Assessment Property Record Card for Tax Year 2026**

Data provided by LISA DELOZIER County Assessor

Date 04/18/2026  
 Time 11:20:54  
 Page 3

Sketch Image

660109137

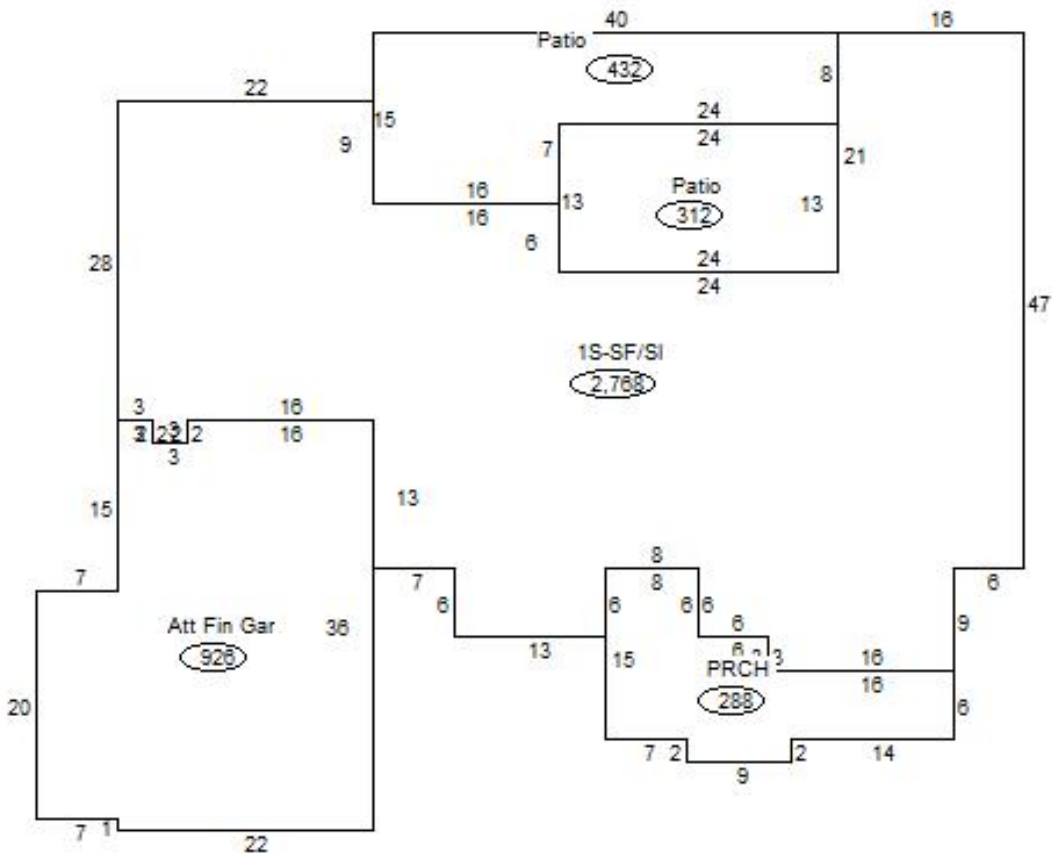

**Sketch Vector Information**

Sequence	Code	Type	Built Over	Scale	Section Label	Base Area	Multiplier	Total Area
1	R	1	Slab	20	1S-SF/Sl	2,768	1.000	2,768
2	G	5		20	Att Fin Gar	926	1.000	926
3	M	PRCH		20	PRCH	288	1.000	288
4	M	PATC		20	Patio	312	1.000	312
5	M	PATO		20	Patio	432	1.000	432
<b>Total Building Area</b>						<b>2,768</b>		<b>2,768</b>